

UNCLASSIFIED



NONRESIDENT
TRAINING
COURSE



March 2012

**Navy Electricity and
Electronics Training
Series**

**Module 6—Electronic Emission, Tubes, and
Power Supplies**

NAVEDTRA 14178A

S/N 0504LP1122347

Notice: NETPDTC is no longer responsible for the content accuracy of the NRTCs.

For content issues, contact the servicing Center of Excellence: Center for Surface Combat Systems; (540) 284-1061 or DSN: 234.

For course registration, issues, or login issues contact the NRTC Helpdesk at: 1-877-264-8583 DSN: 922-1511 or Email: NRTC@navy.mil

DISTRIBUTION STATEMENT A: Approved for public release; distribution is unlimited.

UNCLASSIFIED

UNCLASSIFIED

Although the words “he,” “him,” and “his” are used sparingly in this course to enhance communication, they are not intended to be gender driven or to affront or discriminate against anyone.

DISTRIBUTION STATEMENT A: Approved for public release; distribution is unlimited.

UNCLASSIFIED

UNCLASSIFIED

PREFACE

By enrolling in this self-study course, you have demonstrated a desire to improve yourself and the Navy. Remember, however, this self-study course is only one part of the total Navy training program. Practical experience, schools, selected reading, and your desire to succeed are also necessary to successfully round out a fully meaningful training program.

THE COURSE: This self-study course is organized into subject matter areas, each containing learning objectives to help you determine what you should learn along with text and illustrations to help you understand the information. The subject matter reflects day-to-day requirements and experiences of personnel in the rating or skill area. It also reflects guidance provided by Enlisted Community Managers (ECMs) and other senior personnel, technical references, instructions, etc., and either the occupational or naval standards, which are listed in the *Manual of Navy Enlisted Manpower Personnel Classifications and Occupational Standards*, NAVPERS 18068.

THE QUESTIONS: The questions that appear in this course are designed to help you understand the material in the text.

VALUE: In completing this course, you will improve your military and professional knowledge. Importantly, it can also help you study for the Navy-wide advancement in rate examination. If you are studying and discover a reference in the text to another publication for further information, look it up.

2012 Edition

Published by
Center for Surface Combat Systems (CSCS)

**NAVSUP Logistics Tracking Number
0504-LP-112-2347**

Sailor's Creed

“I am a United States Sailor.

I will support and defend the
Constitution of the United States of
America and I will obey the orders of those
appointed over me.

I represent the fighting spirit of the Navy
and those who have gone before me to
defend freedom and democracy around the
world.

I proudly serve my country's Navy combat
team with honor, courage and commitment.

I am committed to excellence and the fair
treatment of all.”

UNCLASSIFIED

TABLE OF CONTENTS

CHAPTER	PAGE
1 Introduction to Electron Tubes.....	1-1
2 Special-Purpose Tubes.....	2-1
3 Power Supplies.....	3-1
 APPENDIX	
A Glossary.....	A-1

Course Assignments follow Appendix A

UNCLASSIFIED

NAVY ELECTRICITY AND ELECTRONICS TRAINING SERIES

The Navy Electricity and Electronics Training Series (NEETS) was developed for use by personnel in many electrical and electronic-related Navy ratings. Written by, and with the advice of, senior technicians in these ratings, this series provides beginners with fundamental electrical and electronic concepts through self-study. The presentation of this series is not oriented to any specific rating structure, but is divided into modules containing related information organized into traditional paths of instruction.

The series is designed to give small amounts of information that can be easily digested before advancing further into the more complex material. For a student just becoming acquainted with electricity or electronics, it is highly recommended that the modules be studied in their suggested sequence.

Considerable emphasis has been placed on illustrations to provide a maximum amount of information. In some instances, knowledge of basic algebra may be required.

Course descriptions and ordering information may be found at <https://www.netc.navy.mil> then click on the Programs tab, then select the Nonresident Training Courses from the list.

Throughout the text of this course and while using technical manuals associated with the equipment you will be working on, you will find the below notations at the end of some paragraphs. The notations are used to emphasize that safety hazards exist and care must be taken or observed.

WARNING

AN OPERATING PROCEDURE, PRACTICE, OR CONDITION, ETC., WHICH MAY RESULT IN INJURY OR DEATH IF NOT CAREFULLY OBSERVED OR FOLLOWED.

CAUTION

AN OPERATING PROCEDURE, PRACTICE, OR CONDITION, ETC., WHICH MAY RESULT IN DAMAGE TO EQUIPMENT IF NOT CAREFULLY OBSERVED OR FOLLOWED.

NOTE

An operating procedure, practice, or condition, etc., which is essential to emphasize.

UNCLASSIFIED

STUDENT FEEDBACK AND QUESTIONS

We value your suggestions, questions, and criticisms on our courses. If you would like to communicate with us regarding this course, we encourage you, if possible, to use e-mail or to post your comments on the Community of Practice (COP) page located at <https://wwwa.nko.navy.mil/portal/home/>. If you write or fax, please use a copy of the Student Comment form that follows this page.

For subject matter questions:

E-mail: dlgr_cscs_pqs@navy.mil

Phone: Comm: 540-284-1061

DSN: 234-4639

Address:

COMMANDING OFFICER

Center for Surface Combat Systems

5395 First St

Dahlgren, VA 22448-5200

UNCLASSIFIED

Student Comments

Course Title: NEETS Module 6-Electronic Emission, Tubes, and Power Supplies

NAVEDTRA: 14178A **Date:** _____

We need some information about you:

Rate/Rank and Name: _____ Command/Unit: _____

Street Address: _____ City: _____ State/FPO: _____ Zip _____

Your comments, suggestions, etc.:

Privacy Act Statement: Under authority of Title 5, USC 301, information regarding your military status is requested in processing your comments and in preparing a reply. This information will not be divulged without written authorization to anyone other than those within DOD for official use in determining performance.

UNCLASSIFIED

This page left intentionally blank.

UNCLASSIFIED

NEETS MODULE 6-Electronic Emission, Tubes, and Power Supplies

UNCLASSIFIED

1 INTRODUCTION TO ELECTRON TUBES

LEARNING OBJECTIVES

Learning objectives are stated at the beginning of each chapter. These learning objectives serve as a preview of the information you are expected to learn in the chapter. The comprehensive check questions are based on the objectives. By successfully completing the OCC/ECC, you indicate that you have met the objectives and have learned the information. The learning objectives are listed below.

Upon completion of this chapter, you will be able to:

1. State the principle of thermionic emission and the Edison Effect and give the reasons for electron movement in vacuum tubes.
2. Identify the schematic representation for the various electron tubes and their elements.
3. Explain how the diode, triode, tetrode, and pentode electron tubes are constructed, the purpose of the various elements of the tube, and the theory of operation associated with each tube.
4. State the advantages, disadvantages, and limitations of the various types of electron tubes.
5. Describe amplification in the electron tube, the classes of amplification, and how amplification is obtained.
6. Explain biasing and the effect of bias in the electron tube circuit.
7. Describe the effects the physical structure of a tube has on electron tube operation and name the four most important tube constants that affect efficient tube operation.
8. Describe, through the use of a characteristic curve, the operating parameters of the electron tube.

1.1 INTRODUCTION TO ELECTRON TUBES

In previous study you have learned that current flows in the conductor of a completed circuit when a voltage is present. You learned that current and voltage always obey certain laws. In electronics, the laws still apply. You will use them continuously in working with electronic circuits.

One basic difference in electronic circuits that will at first seem to violate the basic laws is that electrons flow across a gap, a break in the circuit in which there appears to be no conductor. A large part of the field of electronics and the entire field of electron tubes are concerned with the flow and control of these electrons "across the gap." The following paragraphs will explain this interesting phenomenon.

NEETS MODULE 6-Electronic Emission, Tubes, and Power Supplies

UNCLASSIFIED

1.2 THERMIONIC EMISSION

You will remember that metallic conductors contain many free electrons, which at any given instant are not bound to atoms. These free electrons are in continuous motion. The higher the temperature of the conductor, the more agitated are the free electrons, and the faster they move. A temperature can be reached where some of the free electrons become so agitated that they actually escape from the conductor. They "boil" from the conductor's surface. The process is similar to steam leaving the surface of boiling water.

Heating a conductor to a temperature sufficiently high causing the conductor to give off electrons is called THERMIONIC EMISSION. The idea of electrons leaving the surface is shown in figure 1-1.

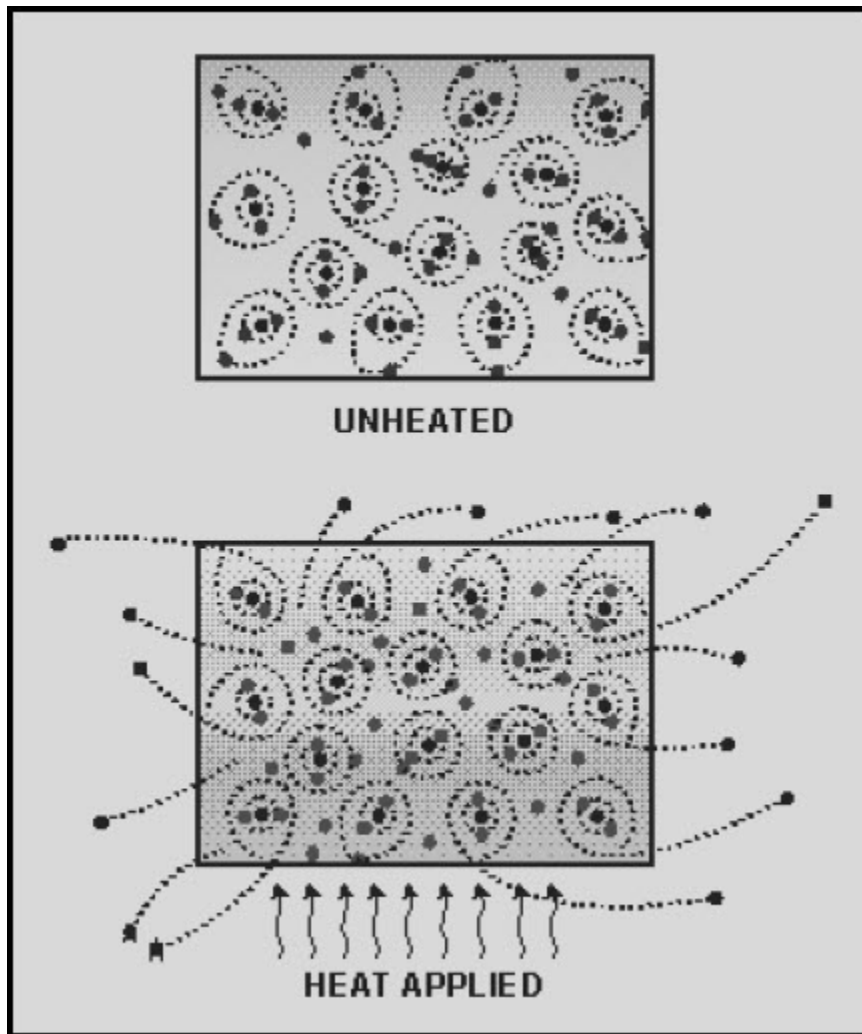

Figure 1-1 Thermionic emission

NEETS MODULE 6-Electronic Emission, Tubes, and Power Supplies UNCLASSIFIED

Thomas Edison discovered the principle of thermionic emission as he looked for ways to keep soot from clouding his incandescent light bulb. Edison placed a metal plate inside his bulb along with the normal filament. He left a gap, a space, between the filament and the plate. He then placed a battery in series between the plate and the filament, with the positive side toward the plate and the negative side toward the filament. This circuit is shown in figure 1-2.

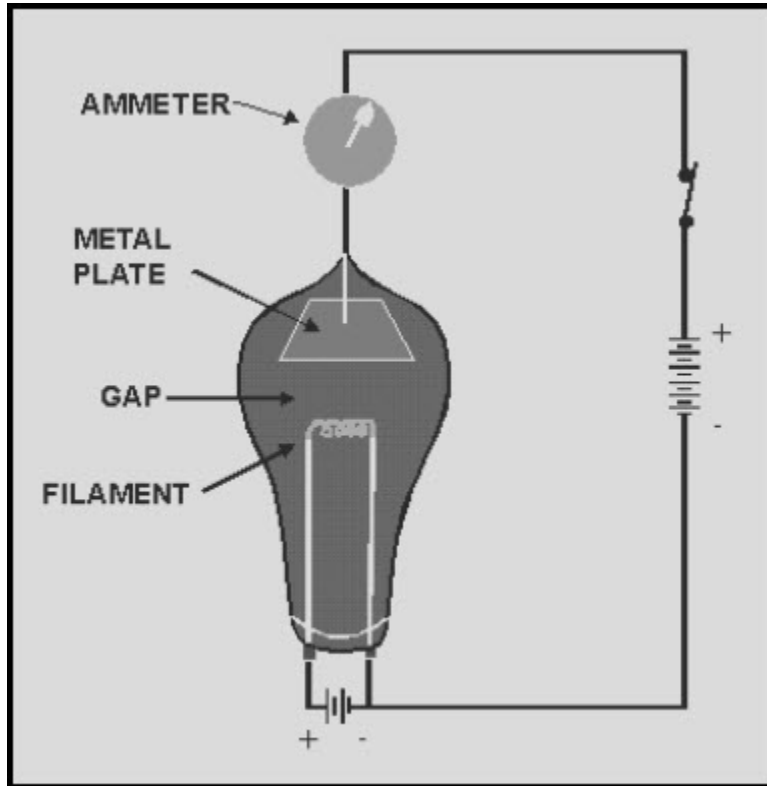

Figure 1-2 Edison's experimental circuit

When Edison connected the filament battery and allowed the filament to heat until it glowed, he discovered that the ammeter in the filament-plate circuit had deflected and remained deflected. He reasoned that an electrical current must be flowing in the circuit—**EVEN ACROSS THE GAP** between the filament and plate.

Edison could not explain exactly what was happening. At that time, he probably knew less about what makes up an electric circuit than you do now. Because it did not eliminate the soot problem, he did little with this discovery. However, he did patent the incandescent light bulb and made it available to the scientific community.

NEETS MODULE 6-Electronic Emission, Tubes, and Power Supplies

UNCLASSIFIED

Let's analyze the circuit in figure 1-2. You probably already have a good idea of how the circuit works. The heated filament causes electrons to boil from its surface. The battery in the filament-plate circuit places a **POSITIVE** charge on the plate (because the plate is connected to the positive side of the battery). The electrons (negative charge) that boil from the filament are attracted to the positively charged plate. They continue through the ammeter, the battery, and back to the filament. You can see that electron flow across the space between filament and plate is actually an application of a basic law you already know—**UNLIKE CHARGES ATTRACT**.

Remember, Edison's bulb had a vacuum so the filament would glow without burning. Also, the space between the filament and plate was relatively small. The electrons emitted from the filament did not have far to go to reach the plate. Thus, the positive charge on the plate was able to attract the negative electrons.

The key to this explanation is that the electrons were floating free of the hot filament. It would have taken hundreds of volts, probably, to move electrons across the space if they had to be forcibly pulled from a cold filament. Such an action would destroy the filament and the flow would cease.

The application of thermionic emission that Edison made in causing electrons to flow across the space between the filament and the plate has become known as the **EDISON EFFECT**. It is fairly simple and extremely important. Practically everything that follows will be related in some way to the Edison effect. Be sure you have a good understanding of it before you go on.

Q1. How can a sheet of copper be made to emit electrons thermionically?

Q2. Why do electrons cross the gap in a vacuum tube?

NEETS MODULE 6-Electronic Emission, Tubes, and Power Supplies

UNCLASSIFIED

1.3 THE DIODE TUBE

The diode vacuum tube we are about to study is really Edison's old incandescent bulb with the plate in it. Diode means two elements or two electrodes, and refers to the two parts within the glass container that make up the tube. We have called them filament and plate. More formally, they are called **CATHODE** and **PLATE**, respectively. Sometimes the filament is called a **HEATER**, for obvious reasons-more on this later.

Within a few years after the discovery of the Edison effect, scientists had learned a great deal more than Edison knew at the time of his discovery. By the early 1900s, J.J. Thomson in England had discovered the electron. Marconi, in Italy and England, had demonstrated the wireless, which was to become the radio. The theoretical knowledge of the nature of electricity and things electrical was increasing at a rapid rate.

J.A. Fleming, an English scientist, was trying to improve on Marconi's relatively crude wireless receiver when his mind went back to Edison's earlier work. His subsequent experiments resulted in what became known as the **FLEMING VALVE** (the diode), the first major step on the way to electronics.

1.3.1 Operation of the Diode Tube

Before learning about Fleming's valve, the forerunner of the modern diode, let's look at Edison's original circuit. This time, however, we'll draw it as a schematic diagram, using the symbol for a diode instead of a cartoon-like picture. The schematic is shown in figure 1-3.

Note that this is really two series circuits. The filament battery and the filament itself form a series circuit. This circuit is known as the *filament circuit*.

The path of the second series circuit is from one side of the filament, across the space to the plate, through the ammeter and battery, then back to the filament. This circuit is known as the plate circuit.

You will note that a part of the filament circuit is also common to the plate circuit. This part enables the electrons boiled from the filament to return to the filament. No electron could flow anywhere if this return path were not completed. The electron flow measured by the ammeter is known as plate current.

NEETS MODULE 6-Electronic Emission, Tubes, and Power Supplies UNCLASSIFIED

The voltage applied between the filament and plate is known as plate voltage. You will become familiar with these terms and with others that are commonly used with diodes and diode circuits as we progress.

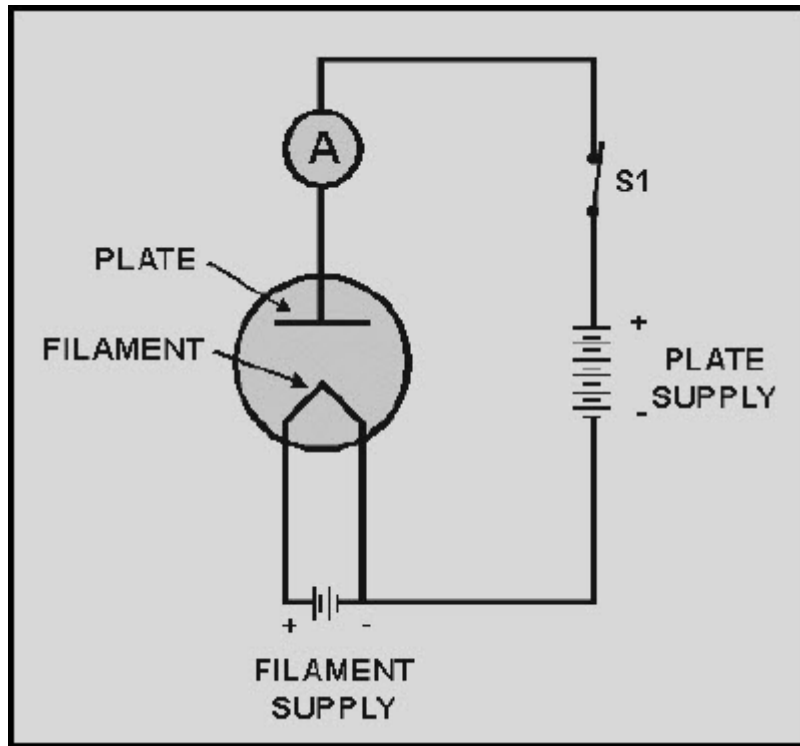

Figure 1-3 Schematic of Edison's experimental circuit

1.3.1.1 Diode Operation with a Positive Plate

Fleming started with a two-element tube (diode) similar to Edison's and at first duplicated Edison's experiment. The results are worth repeating here. Look at figure 1-3 again. With the plate **POSITIVE** relative to the filament, the filament hot, and the circuit completed as shown, the ammeter detected a current flowing in the plate circuit. Because current is the same in all parts of a series circuit, we know that the same current must flow across the space between filament and plate.

We know now that the electrons boiled from the heated filament are **NEGATIVE** and are attracted to the **POSITIVE** plate because **UNLIKE CHARGES ATTRACT**.

NEETS MODULE 6-Electronic Emission, Tubes, and Power Supplies UNCLASSIFIED

1.3.1.2 Diode Operation with a Negative Plate

Fleming's next step was to use a similar circuit but to reverse the plate battery. The circuit is shown in figure 1-4.

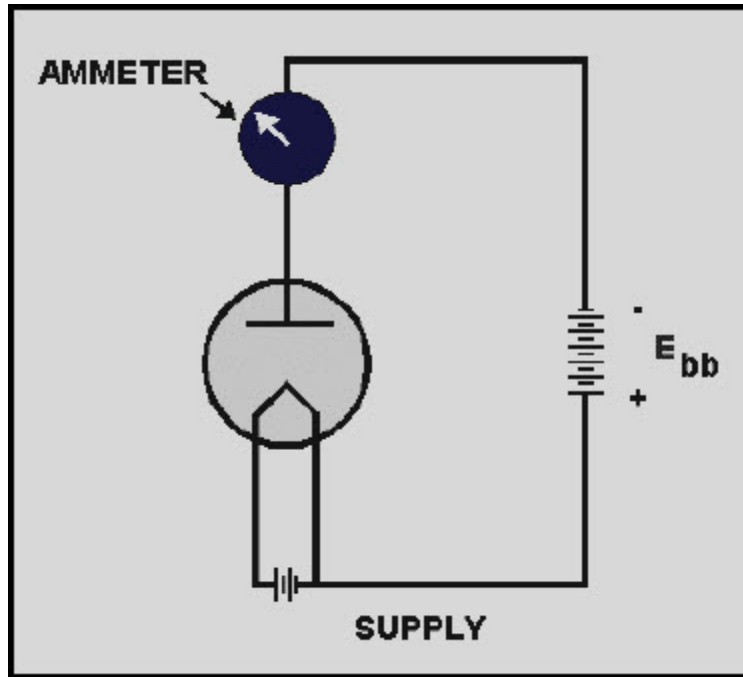

Figure 1-4 Diode with a negative plate

With the plate **NEGATIVE** relative to the filament, the filament hot, and the circuit completed as shown, the ammeter indicated that **ZERO** current was flowing in the plate circuit.

Fleming found that the **NEGATIVE** charge on the plate, relative to the filament, **CUT OFF** the flow of plate current as effectively as if a **VALVE** were used to stop the flow of water in a pipe.

You have all of the facts available that Fleming had. Can you give an explanation of why the diode cuts off current when the plate is negative?

NEETS MODULE 6-Electronic Emission, Tubes, and Power Supplies

UNCLASSIFIED

Let's put the facts together. The filament is hot and electrons boil from its surface. Because the filament is the only heated element in the diode, it is the **ONLY** source of electrons within the space between filament and plate. However, because the plate is **NEGATIVE** and the electrons are **NEGATIVE**, the electrons are repelled back to the filament. Remember that **LIKE CHARGES REPEL**. If electrons cannot flow across the space, then no electrons can flow anywhere in the plate circuit. The ammeter therefore indicates **ZERO**.

It might seem to you that electrons flow from the negative plate to the positive filament under these conditions. This is **NOT** the case. Remember that it takes a heated element to emit electrons and that the filament is the only heated element in the diode. The plate is cold. Therefore, electrons cannot leave the plate, and plate-to-filament current cannot exist.

The following is a summary of diode operation as we have covered it to this point:

Assume that all parts of the circuit are operable and connected.

- PLATE CURRENT FLOWS WHEN THE PLATE IS POSITIVE
- PLATE CURRENT IS CUT OFF WHEN THE PLATE IS NEGATIVE
- PLATE CURRENT FLOWS ONLY IN ONE DIRECTION-FROM THE FILAMENT TO THE PLATE

1.3.1.3 Measuring Diode Voltages

As you know, it is impossible to have a voltage at one point, because voltage is defined as a **DIFFERENCE** of **POTENTIAL** between two points. In our explanation above we referred to plate voltage. To be exactly right, we should refer to plate voltage as the **VOLTAGE BETWEEN PLATE** and **FILAMENT**. Plate voltages and others that you will learn about soon, are often referred to as if they appear at one point. This should not confuse you if you remember your definition of voltage and realize that voltage is always measured between two points. M1 and M2 in figure 1-5 measure plate voltage and filament voltage, respectively.

NEETS MODULE 6-Electronic Emission, Tubes, and Power Supplies
UNCLASSIFIED

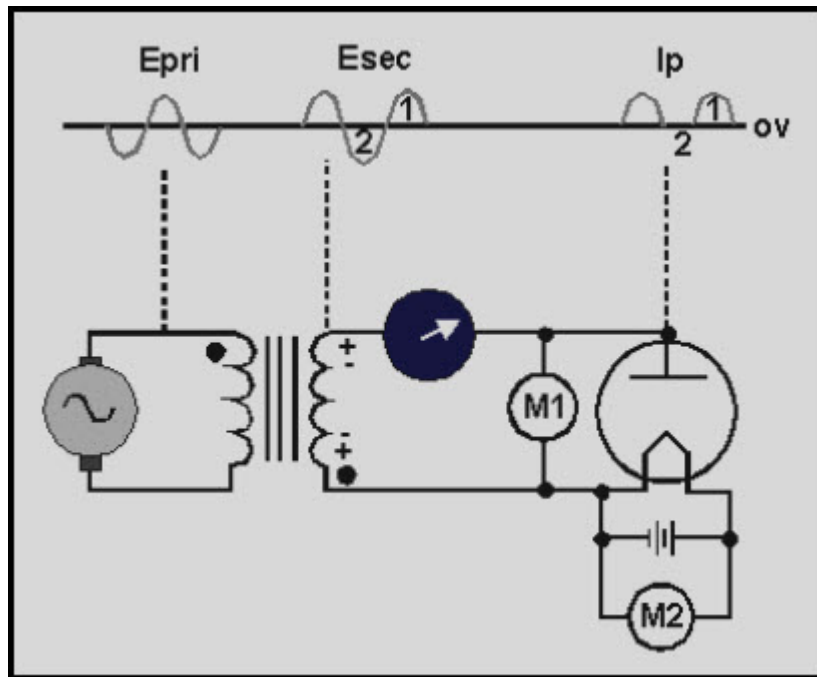

Figure 1-5 Alternating voltage on the plate

The reference point in diode and other tube circuits is usually a common point between the individual circuits within the tube. The reference point (common) in figure 1-5 is the conductor between the bottom of the transformer secondary and the negative side of the filament battery. Note that one side of each voltmeter is connected to this point.

Q3. Name the two series circuits that exist in a diode circuit.

Q4. Before a diode will conduct, the cathode must be what polarity relative to the plate?

NEETS MODULE 6-Electronic Emission, Tubes, and Power Supplies

UNCLASSIFIED

1.3.1.4 Diode Operation with an Alternating Voltage on the Plate

After experimenting with a positive plate and a negative plate, Fleming replaced the direct voltage of the battery with an alternating voltage. In our explanation, we'll use a transformer as the source of alternating voltage. The circuit is shown in figure 1-5.

Note that the only real difference in this circuit from the previous ones is the transformer. The transformer secondary is connected in series with the plate circuit—where the plate battery was previously.

Remember from your study of transformers that the secondary (output) of a transformer always produces an alternating voltage. The secondary voltage is a sine wave as shown in the figure.

You'll remember that the sine wave is a visual picture, a graph of the change in alternating voltage as it builds from zero to a maximum value (positive) and then drops to zero again as it decreases to its minimum value (negative) in the cycle.

Assume that the polarity across the secondary during the first half-cycle of the input ac voltage is as shown in the figure. During this entire first half-cycle period, the plate's polarity will be **POSITIVE**. Under this condition, plate current flows, as shown by the ammeter.

The plate current will rise and fall because the voltage on the plate is rising and falling. Remember that current in a given circuit is directly proportional to voltage.

During the second half-cycle period, plate's polarity will be **NEGATIVE**. Under this condition, for this entire period, the diode will not conduct. If our ammeter could respond rapidly, it would drop to zero. The plate-current waveform (I_p) in figure 1-5 shows zero current during this period.

Here is a summary of effects of applying alternating voltage to the plate of the diode:

1. Diode plate current flows during the positive half-cycle. It changes value as the plate voltage rises and falls.
2. The diode cuts off plate current during the entire period of the negative half-cycle.
3. Diode plate current flows in **PULSES** because the diode cuts off half the time.
4. Diode plate current can flow in only one direction. It is always a direct current. (In this case **PULSATING DC** - one that flows in pulses.)
5. In effect, the diode has caused an alternating voltage to produce a direct current.

NEETS MODULE 6-Electronic Emission, Tubes, and Power Supplies

UNCLASSIFIED

The ability to obtain direct current from an ac source is very important and one function of a diode that you will see again and again wherever you work in electronics.

The circuits that we have discussed up to this point were chosen to show the general concepts discovered by Edison and Fleming. They are not practical because they do no useful work. For now, only the concepts are important. Practical circuitry will be presented later in this chapter as you learn specific points about the construction, limitations, and other characteristics of modern diode tubes.

Q5. An ac voltage is applied across a diode. The tube will conduct when what alternation of ac is applied to the plate?

Q6. What would be the output of the circuit described in question 5?

1.3.2 Diode Construction

Diode tubes in present use are descendants of Fleming's valve. There is a family resemblance, but many changes have been made from the original. Diodes are both smaller and larger, less powerful and more powerful, and above all, more efficient and more reliable. The search for greater efficiency and reliability has resulted in many physical changes, a few of which will be covered in the next paragraphs.

Most of what is said here about construction and materials will be true of all electron tubes, not just diodes.

1.3.2.1 Filaments

Modern filaments in **ALL** tubes last longer, emit greater amounts of electrons for a given size, and many operate at a lower temperature than in the early days. Most improvements have resulted from the use of new materials and from better quality control during manufacture.

Three materials that are commonly used as filaments are tungsten, thoriated tungsten, and oxide-coated metals.

NEETS MODULE 6-Electronic Emission, Tubes, and Power Supplies

UNCLASSIFIED

Tungsten has great durability but requires large amounts of power for efficient thermionic emission. Thoriated-tungsten filaments are made of tungsten with a very thin coat of thorium, which makes a much better emitter of electrons than just tungsten. Oxide-coated filaments are made of metal, such as nickel, coated with a mixture of barium and strontium oxides. The oxide coat, in turn, is coated with a one-molecule-thick layer of metal barium and strontium. Oxide coating produces great emission efficiency and long life at relatively low heat.

A major advance in electronics was the elimination of batteries as power sources for tubes. Except in electronic devices designed to be operated away from the ac power source, alternating current is used to heat filaments.

Voltage may be supplied by a separate filament transformer or it may be taken from a filament winding that is part of a power transformer. The actual voltage may vary from 1 volt up and depends on the design of the tube. Common filament voltages are 5.0, 6.3, and 12.6 volts ac. Filaments may be connected in series with other tube filaments or may be in parallel with each other. This is determined by the equipment designer.

1.3.2.2 Cathodes

As was mentioned previously, a more formal name for the electron-emitting element in a tube is the **CATHODE**.

Cathodes in all tubes, not just diodes, are of two general types, either directly heated or indirectly heated. Each has its advantages and disadvantages.

NEETS MODULE 6-Electronic Emission, Tubes, and Power Supplies UNCLASSIFIED

DIRECTLY HEATED - The filament that has been discussed so far is the directly heated cathode. Directly heated cathodes are fairly efficient and are capable of emitting large amounts of electrons. Figure 1-6 shows this type and its schematic symbol.

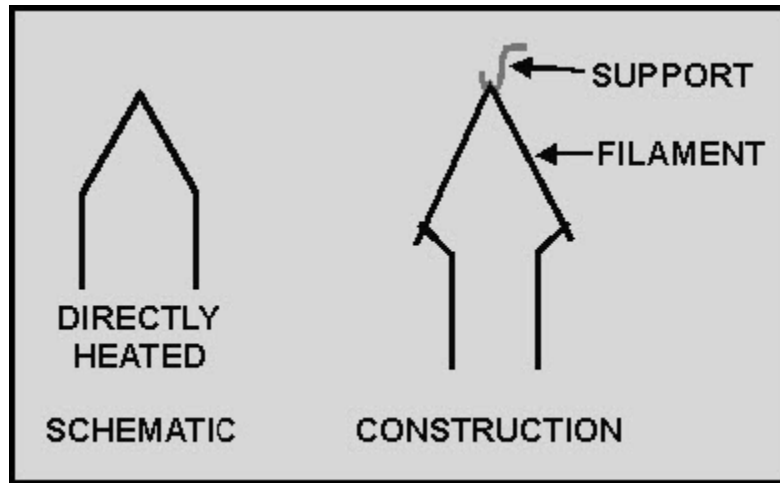

Figure 1-6 Cathode schematic representation

An added advantage of this type of filament is the rapidity with which it reaches electron-emitting temperature. Because this is almost instantaneous, many pieces of electronic equipment that must be turned on at infrequent intervals and be instantly usable have directly heated cathode tubes.

There are disadvantages. Because of its construction, parts of the filament are closer to the plate than other parts. This results in unequal emission and a loss of efficiency. Another disadvantage occurs when dc is used to heat a filament. The filament represents a resistance. When current flows through this resistance, a voltage drop occurs. The result is that one side of the resistance, or filament, is more negative than the other side. The negative side of the filament will emit more electrons than the positive side; which, again, is less efficient than if the filament has equal emission across its entire surface.

When ac is the source of filament power, it causes a small increase and decrease of temperature as it rises and falls. This causes a small increase and decrease of emitted electrons. This effect is not too important in many diode circuits, but it is undesirable in other tube circuits.

NEETS MODULE 6-Electronic Emission, Tubes, and Power Supplies UNCLASSIFIED

INDIRECTLY HEATED - Figure 1-7 shows this type of cathode and its schematic symbol. Indirectly heated cathodes are always composed of oxide-coated material. The cathode is a cylinder, a kind of sleeve that encloses the twisted wire filament. The only function of the filament is to heat the cathode. The filament is often called a heater when used in this manner.

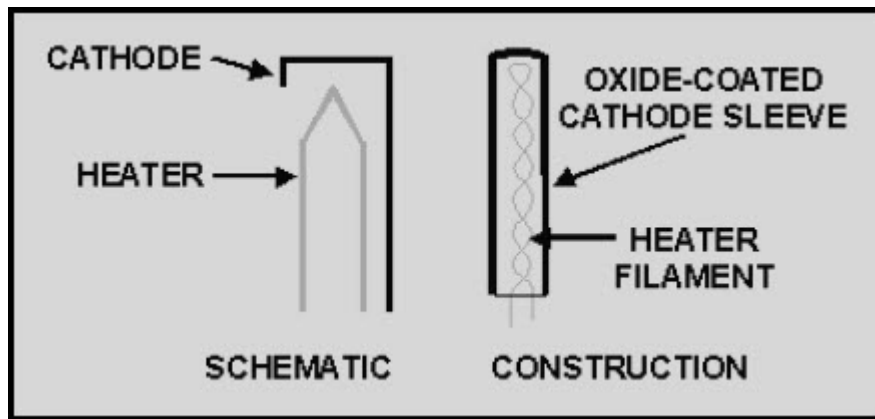

Figure 1-7 Indirectly heated cathode schematic

Some schematics do not show heaters and heater connections. Heaters, of course, are still present in the tubes, but their appearance in a schematic adds little to understanding the circuit. The heater is not considered to be an active element. For example, a tube with an indirectly heated cathode and a plate is still called a diode, even though it might seem that there are three elements in the tube.

Because indirectly heated cathodes are relatively large, they take longer to heat to electron-emitting temperature. Once up to temperature, however, they do not respond to the small variations in heater temperature caused by ac fluctuations. Because of the inherent advantages, most tubes in use today have indirectly heated cathodes.

Q7. Besides tungsten, what other materials are used for cathodes in vacuum tubes?

Q8. What is the advantage of directly heated cathodes?

NEETS MODULE 6-Electronic Emission, Tubes, and Power Supplies

UNCLASSIFIED

1.3.2.3 Plates

Edison's plate was just that—a plate, a flat piece of metal. Plates are no longer flat but are designed in many different shapes. Figure 1-8 shows two diodes, one with a directly heated cathode, the other with an indirectly heated cathode. Each plate is cut away to show the internal position of elements and the plate shapes.

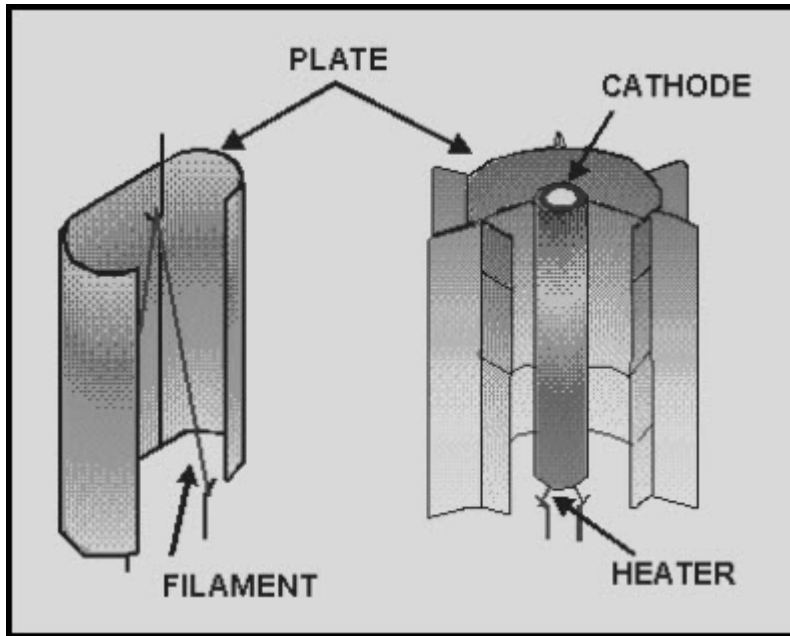

Figure 1-8 Cutaway view of plate construction

Plates must be able to hold up under the stress of heat created by the flow of plate currents and the closeness of hot cathodes. They need to be strong enough to withstand mechanical shocks produced by vibration and handling.

Some typical materials used for electron tube plates are tungsten, molybdenum, graphite, nickel, tantalum, and copper.

NEETS MODULE 6-Electronic Emission, Tubes, and Power Supplies

UNCLASSIFIED

1.3.2.4 Tube Bases

The base shown in figure 1-9 has two functions. First, it serves as the mounting for tube elements. Second, it serves as the terminal points for the electrical connections to the tube elements. This is accomplished by molding or otherwise bringing pins (or prongs) through the base. The internal ends of these pins are connected to tube elements. The pins themselves are male connections.

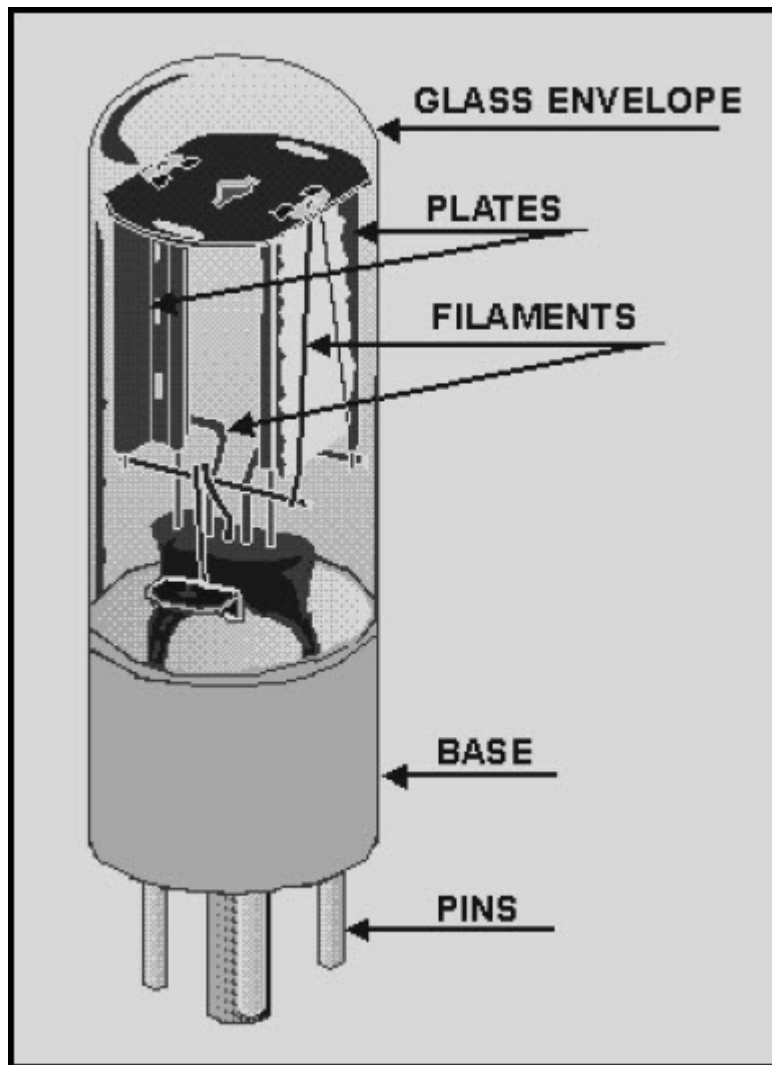

Figure 1-9 Diode construction

NEETS MODULE 6-Electronic Emission, Tubes, and Power Supplies UNCLASSIFIED

The base must be mechanically strong and made of an insulating material to prevent the tube elements from shorting.

Because they require relatively frequent replacement, most tubes are designed to plug into sockets permanently mounted in the equipment. Tube pins and sockets are so designed that tubes cannot be plugged in incorrectly.

Tube sockets must make secure mechanical and electrical contact with tube pins, must insulate pins from each other, and must provide terminals to which circuit components and conductors are connected.

Each element of a tube is connected to a pin in its base. To trace a circuit easily and efficiently, you must match elements with their pin numbers. This information is available in tube manuals and equipment schematics. Figure 1-10 shows these numbers on one example of a diode symbol. You will also note the designation V1 beside the tube. Electron tubes are often identified in schematic diagrams by the letter V and a number.

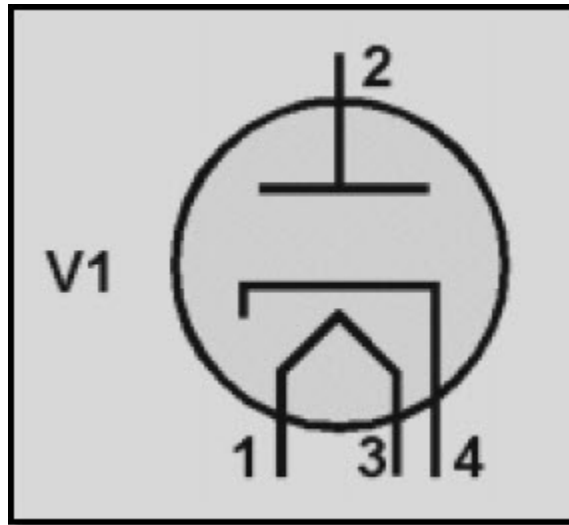

Figure 1-10 Identification of tube elements

Now, to use the information in the symbol, you need to know the system used to number tube pins and socket connections.

NEETS MODULE 6-Electronic Emission, Tubes, and Power Supplies UNCLASSIFIED

Figure 1-11 shows five common pin configurations as viewed from the bottom of each tube or socket. This is important. In every case, pins and pin connections on sockets are numbered in a clockwise direction - **WHEN VIEWED FROM THE BOTTOM**.

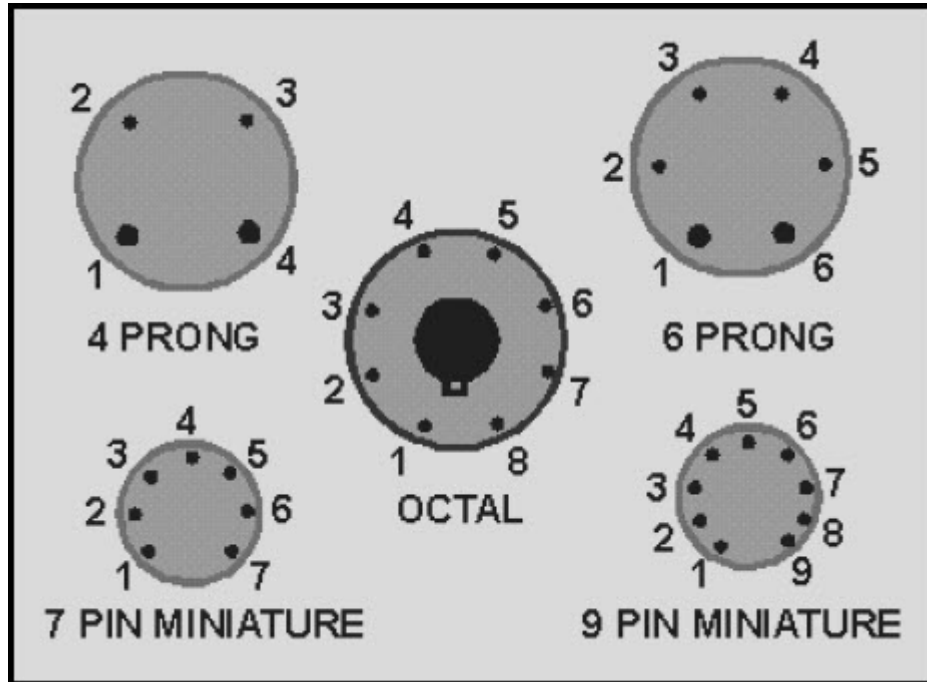

Figure 1-11 Pin Identification; all tubes are viewed from the bottom

In each of the five pictures in figure 1-11, there is an easily identified point from which to start numbering. In the 4-prong and 6-prong tubes, the point is between the two larger prongs. In the octal tube, the point is directly down from the keyway in the center of the tube. In the 7-pin and 9-pin miniatures, the point is identified by the larger distance between pins.

Q9. Name two functions of the base of a vacuum tube.

NEETS MODULE 6-Electronic Emission, Tubes, and Power Supplies

UNCLASSIFIED

1.3.2.5 The Envelope

The envelope of a tube may be made of ceramic, metal, or glass. Its major purpose is to keep the vacuum in and the atmosphere out. The main reason for this is that the heated filament would burn up in the atmosphere. There are other reasons for providing a vacuum, but the important thing is to realize that a tube with a leaky envelope will not function properly.

The silver spot you will sometimes see on the inside surface of the glass envelope of a vacuum tube is normal. It was caused by the "flashing" of a chemical during the manufacture of the tube. Burning the chemical, called the **GETTER**, helps to produce a better vacuum and eliminates any remaining gases.

1.3.3 Electrical Parameters of Diodes

Thousands of different tubes exist. While many of them are similar and even interchangeable, many have unique characteristics. The differences in materials, dimensions, and other physical characteristics, such as we have just covered, result in differing electrical characteristics.

The electrical parameters of a diode, and any tube, are specific. In the process of discussing these parameters, we will state exact values. Voltages will be increased and decreased and the effects measured. Limiting factors and quantities will be explored and defined. The discussion will be based on simplified and experimental circuits.

It is important for you to realize that practically all of the parameters, limitations, definitions, abbreviations, and so on that we will cover in these next paragraphs will apply directly to the more complex tubes and circuits you will study later. Diode parameters are the foundation for all that follows.

1.3.3.1 Symbols

You have learned to use letters and letter combinations to abbreviate or symbolize electrical quantities. (The letters E, I, and R are examples.) We will continue this practice in referring to tube quantities. You should be aware that other publications may use different abbreviations. Many attempts have been made to standardize such abbreviations, inside the Navy and out. None have succeeded completely.

NEETS MODULE 6-Electronic Emission, Tubes, and Power Supplies UNCLASSIFIED

Table 1-1 lists electron-tube symbols used in the remainder of this chapter. The right-hand column shows equivalent symbols that you may find in **OTHER** texts and courses.

Table 1-1 Symbols for Tube Parameters

SYMBOLS THIS TEXT	MEANING	OTHER TEXTS
E_p	PLATE VOLTAGE, D.C. VALUE	
E_{bb}	PLATE SUPPLY VOLTAGE, D.C.	B+
E_c	GRID BIAS VOLTAGE, D.C. VALUE	E_g
E_{cc}	GRID BIAS SUPPLY VOLTAGE, D.C.	C-
e_b	INSTANTANEOUS PLATE VOLTAGE	
e_c	INSTANTANEOUS GRID VOLTAGE	
e_g	A.C. COMPONENT OF GRID VOLTAGE	
e_p	A.C. COMPONENT OF PLATE VOLTAGE (ANODE)	
I_p	D.C. PLATE CURRENT	
R_p	D.C. PLATE RESISTANCE	
R_g	GRID RESISTANCE	
R_k	CATHODE RESISTANCE	
R_L	LOAD RESISTANCE	

1.3.3.2 Plate Voltage-Plate Current Characteristic

You know that a positive voltage on the diode plate allows current to flow in the plate circuit. Each diode, depending on the physical and electrical characteristics designed into the diode, is able to pass an exact amount of current for each specific plate voltage (more voltage, more current—at least to a point).

The plate voltage-plate current characteristic for a given diode is a measure of exactly how much plate voltage controls how much plate current. This is often called the $E_p - I_p$ characteristic.

The $E_p - I_p$ characteristic for a given diode, is determined by design engineers using mathematical analysis and laboratory experiment. You, as a technician, will never need to do this. However, you will use the results obtained by the engineers. You will also use your knowledge of the diode as you analyze equipment malfunction.

NEETS MODULE 6-Electronic Emission, Tubes, and Power Supplies UNCLASSIFIED

Assume that we have the circuit in figure 1-12. (The filament has the proper voltage-even though it isn't shown on the diagram.) Our purpose is to determine just how a changing voltage on the plate changes (or controls) the plate current. The method is as follows:

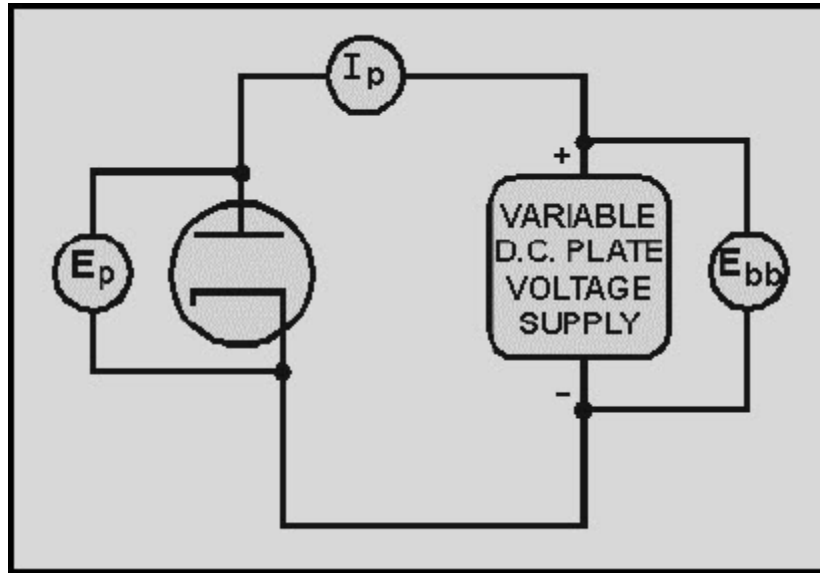

Figure 1-12 Determining diode plate characteristic

1. Starting with zero volts from our variable dc voltage source, increase the plate voltage (E_p) in steps of 50 volts until you reach 400 volts.
2. At each 50-volt step, measure the milliamperes of plate current (I_p) that flow through the meter. Record the I_p meter readings, step by step, so that you may analyze the results.

NEETS MODULE 6-Electronic Emission, Tubes, and Power Supplies

UNCLASSIFIED

Assume that table 1-2 shows our results. While we could use the table, a more normal procedure is to plot a graph of the values. Such a graph is called an **$E_p - I_p$ CURVE** and is shown in figure 1-13. Each tube has its own $E_p - I_p$ curve, which is available in commercial tube manuals and in many equipment technical manuals. Each curve will be different in some respects from every other curve. The shapes, however, will be similar.

Table 1-2 $E_p - I_p$ Values Obtained by Experiment

E_p	0	50	100	150	200	250	300	350	400
I_p	0	.002	.005	.010	.020	.030	.040	.042	.045

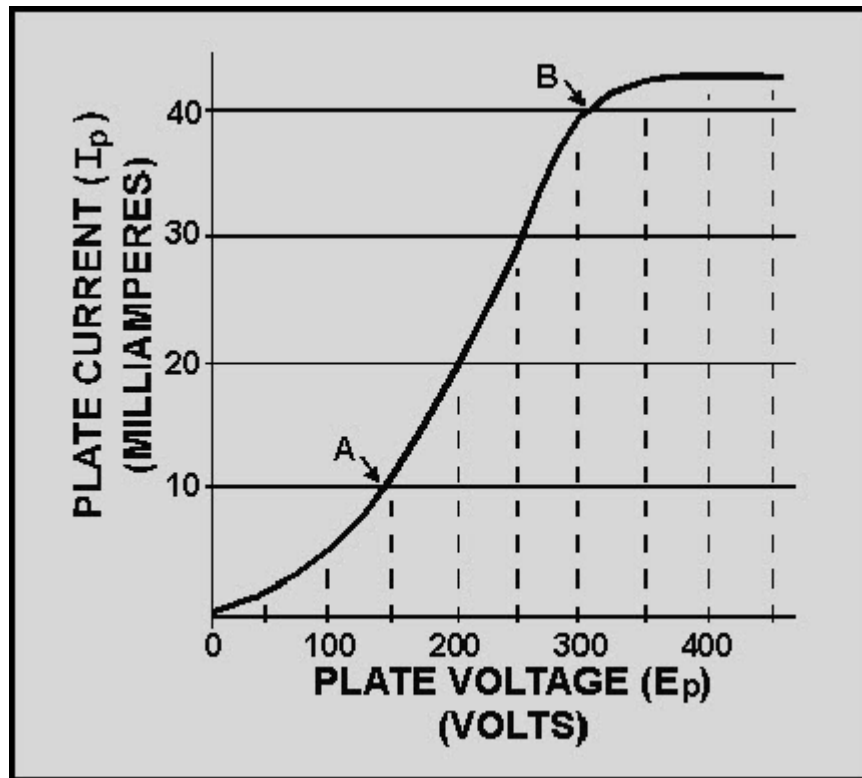

Figure 1-13 $E_p - I_p$ characteristic curve

NEETS MODULE 6-Electronic Emission, Tubes, and Power Supplies

UNCLASSIFIED

The $E_p - I_p$ curve in figure 1-13, although just an example, is typical of real plate characteristic curves. You may learn certain characteristics that apply to both diodes and other tubes by studying it.

First, look at the part of the curve to the left of point A. Because it is not a straight line, it is referred to as **NONLINEAR**. Note that a change of 150 volts (0-150) caused a change of 10 mA of plate current (0-10). In comparison with the straight-line part of the curve, between points A and B, this is a relatively small change in current. The smaller the change in current, the flatter the curve.

In explaining this **NONLINEAR** portion of the curve, let's go back just a bit to electron emission. The electrons emitted by a cathode form a cloud around the cathode. This cloud is called the **SPACE CHARGE**. The closer the space charge is to the cathode, the more densely packed it is with electrons. In our example, the lower plate voltages (0-150 volts) over this part of the curve exert a pull on only the outer fringe of the space charge where there are few electrons. This results in relatively few electrons flowing to the plate.

Now look at the center portion of the curve between A and B. This is known as the **LINEAR** portion because it is nearly a **STRAIGHT LINE**. Over this portion, a change of 50 volts E_p causes a change of 10 mA I_p .

The reason for the increased change in plate current for a given change of plate voltage also has to do with the space charge. With a higher plate voltage (over 150 volts), the attraction from the plate begins to influence the **DENSER** part of the space charge that has greater numbers of electrons. Therefore, a higher current flows for a given voltage than in the nonlinear part. The curve becomes steeper. In our example, this linearity continues to about 300 volts, point B.

Lastly, let's look at the top portion of the curve. The plate current plotted here is produced by the higher plate voltages. However, the amount of current change for a given voltage change is greatly reduced. The reason for this again involves the space charge. At about 300 volts, almost all of the electrons in the space charge are flowing to the plate. A higher voltage cannot attract more electrons because the cathode cannot produce any more. The point where all (or almost all) available electrons are being drawn to the plate is called **PLATE SATURATION** or just **SATURATION**. This is one of the limiting factors of every tube.

You can see from the analysis that the most consistent control of plate current takes place over the linear portion of the $E_p - I_p$ curve. In most applications, electron tubes are operated in this linear portion of the characteristic curve.

NEETS MODULE 6-Electronic Emission, Tubes, and Power Supplies

UNCLASSIFIED

1.3.3.3 Plate Resistance (R_p)

One tube parameter that can be calculated from values on the $E_p - I_p$ curve is known as plate resistance, abbreviated as R_p . In a properly designed electron tube, there is no physical resistor between cathode and plate; that is, the electrons do not pass through a resistor in arriving at the plate. You may have wondered, however, why the variable dc voltage source of figure 1-12 didn't blow a fuse. Doesn't the plate circuit appear to be a short circuit—a circuit without a load to limit the current?

The fact is, there is a very real, effective **RESISTANCE** between cathode and plate. It is not lumped in a resistor, but the circuit may be analyzed as if it is. The plate resistance of a given tube, R_p , can be calculated by applying Ohm's law to the values of E_p and I_p . Figure 1-14 is a typical diode $E_p - I_p$ curve. The plate resistance has been figured for R_p under three different conditions, as follows:

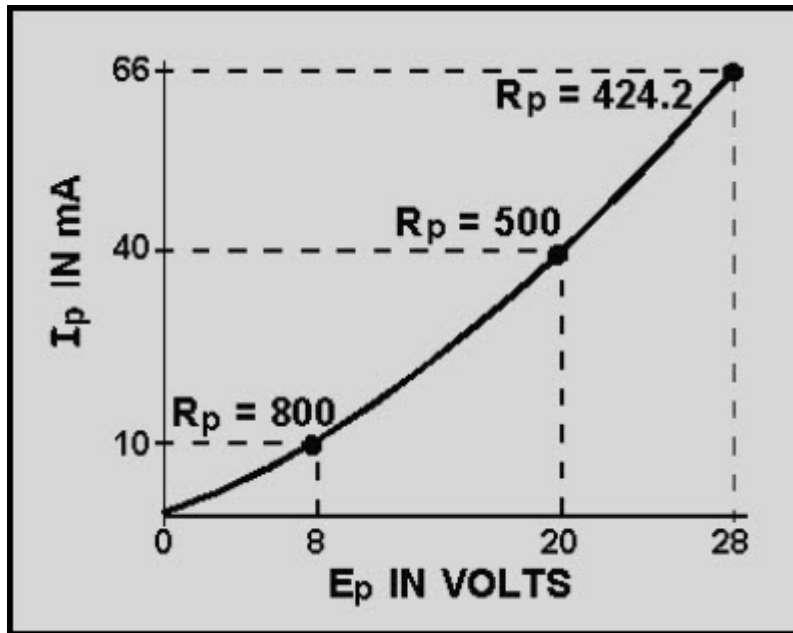

Figure 1-14 The $E_p - I$ characteristic curve for a diode

Remember that 1 mA = .001 ampere; therefore 40 mA = .040 ampere.

NEETS MODULE 6-Electronic Emission, Tubes, and Power Supplies
UNCLASSIFIED

Solution:

$$R_p = \frac{E_p}{I_p}$$

$$R_p = \frac{20 \text{ volts}}{.040 \text{ amperes}}$$

$$R_p = 500 \text{ ohms}$$

The other two indicated values of R_p were figured in the same way.

You should note that there is very little difference in plate resistance when the E_p and I_p values are taken from the linear portions of curves. Check this out with values taken from the linear portion of figure 1-13.

R_p (with a capital R) is the effective resistance offered to direct current.

PLATE RESISTANCE IN GAS DIODES - Gas diodes are a type of tube that we have not yet discussed. They are mentioned here only because of their plate-resistance characteristic.

Instead of a high-vacuum environment, some tubes have small amounts of gas introduced in the envelope vacuum during manufacture. Argon, neon, helium, or mercury vapor are commonly used.

When a certain minimum voltage is placed on the plate, the gas molecules in the envelope ionize. This happens by a process that will be explained when gas diodes are studied. The positive ions tend to cancel some of the effects of the space charge that influence plate resistance in a vacuum tube. This canceling reduces internal plate resistance to a relatively low, constant value. In applications that require a large plate current, the low plate resistance of a gas-filled diode has an efficiency that cannot be approached by a high-vacuum diode.

This and other characteristics of gas tubes will be covered later.

NEETS MODULE 6-Electronic Emission, Tubes, and Power Supplies UNCLASSIFIED

Q10. Vacuum tubes are designed to operate in what portion of the $E_p - I_p$ curve?

Q11. What value can be calculated from the values found on an $E_p - I_p$ curve?

1.3.3.4 Plate Dissipation

When electrons are attracted from the space charge to the plate, they are accelerated by the attraction. Their gain in speed gives them energy that causes them to strike the plate with a considerable force. As the electrons strike the plate, this energy is converted to heat. The plate must be able to withstand the associated increase in temperature. The maximum amount of power (watts) that a given plate can safely dissipate (as heat) is called the **PLATE DISSIPATION** rating.

To find the amount of plate dissipation for a given tube under a particular set of plate conditions, use the following equation:

$$\text{Plate dissipation} = E_p \times I_p$$

For our current problem,

$$\text{Plate dissipation} = 20 \text{ volts} \times .040 \text{ amperes}$$

$$\text{Plate dissipation} = .8 \text{ watt}$$

This is a relatively small wattage. It's probable that the plate of our example diode is not overheating. A tube manual could tell us for sure.

Plate dissipation is a circuit loss that must be made good by the power source in a circuit. In our example, this is the plate voltage supply.

NEETS MODULE 6-Electronic Emission, Tubes, and Power Supplies

UNCLASSIFIED

1.3.3.5 Peak Current Rating

The maximum instantaneous current that a tube can pass in the normal direction (cathode to plate) without damage is called the **PEAK CURRENT RATING**. Peak current rating is determined by the amount of electrons available from the cathode and the length of time plate current flows.

1.3.3.6 Peak Voltage Rating

This is the maximum instantaneous voltage that can be applied to a tube in the normal direction without a breakdown.

1.3.3.7 Peak Inverse Voltage Rating

This is the maximum voltage that can be applied to a tube in the reverse direction (plate negative with respect to the cathode)-exceeding this will cause arc-over from the plate to the cathode and will damage the tube. **PIV**, as this is sometimes abbreviated, becomes very important in the rectifier circuit to be discussed as a later major subject.

1.3.3.8 Transit Time

Things that happen in electricity and electronics are often explained as if they happen instantaneously. As fast as electricity acts, however, the truth is that cause and effect are separated by a certain amount of time.

Each tube has a factor called **TRANSIT TIME**, which is the time required for an individual electron to move from the cathode to the plate. In certain applications involving high-frequency voltages, transit time places a limitation on tubes. We will explain this limitation when we discuss the circuits it affects.

NEETS MODULE 6-Electronic Emission, Tubes, and Power Supplies

UNCLASSIFIED

1.3.4 Summary of Diode Parameters and Limitations

You should now have a basic understanding of diodes, many of their characteristics, and some of their limitations. One of the more important concepts that you should now understand is that most of these characteristics influence each other. For example, practically all plate characteristics are interrelated. Change one and the others change. Another example is heater voltage. Every tube parameter affected by the cathode depends on proper heater voltage. Interrelationships such as these make electronics both fascinating and, at times, frustrating.

Many of the limiting factors that we have discussed are the same ones found in other electrical devices such as motors, stoves, toasters, and so on. Heating and overheating, insulation breakdown, and excessive voltage and current are all limitations that you have noted before.

The point is that you can and should apply just about everything you have learned about electricity to electron tubes. Little is new except the environment.

Q12. A large negative voltage is applied to the plate of a diode, and a large positive voltage is applied to the cathode. If the tube conducts, what tube parameter has been exceeded?

NEETS MODULE 6-Electronic Emission, Tubes, and Power Supplies

UNCLASSIFIED

1.4 THE TRIODE

Diode electron tubes can be used as rectifiers, switches, and in many other useful applications. They are still used in Fleming's original application in some radio circuits. You will learn more of these applications in other *NEETS* modules and later will see the diode in several pieces of electronic equipment.

As with all inventions, Fleming's diode was immediately the subject of much experimentation and many attempts at improvement. An American experimenter, Dr. Lee De Forest, added another active element to the diode in 1906. He was trying to improve the radio application of Fleming's diode. His new tube was eventually called a triode.

DeForest's triode was not very successful as a radio "detector." (Detectors will be studied in a later *NEETS* module.) However, in 1912, De Forest discovered that his original triode could **AMPLIFY** or magnify very weak electrical impulses. It is because of the triode's ability to amplify that De Forest is honored as one of the great radio pioneers.

The immediate application of the triode amplifier was in telephone and radio. Both fields were limited because electrical impulses (signals) became weaker and weaker as the distance from the signal source increased. The triode, along with other developments of the time, made long-distance communications possible. Looking back, we can now see that the amplifying tube was the real beginning of modern electronics and influenced everything that followed. Let's find out more about the idea of amplification and how it is done in the triode.

You are already familiar with a type of amplification. In a previous *NEETS* module, step-up transformers were discussed. You should remember that an input voltage applied to the primary of a step-up transformer is increased in amplitude at the secondary by a factor determined by the step-up turns ratio.

For example, if 5 volts were applied to the primary of a 1:3 step-up transformer, the secondary would produce 15 volts. In other words, the input voltage was amplified by a factor of 3. When applied to electronic circuits, these primary and secondary voltages are more often called signals, or input and output signal, respectively. In electronics, the amplitude of an input signal must sometimes be increased many times-often, hundreds or thousands of times!

Because of size and design limitations, transformers are usually not practical for use in electronics as amplifiers.

DeForest's first experiment with the diode was to place an additional metal plate between the cathode and plate. He then placed an ac signal on the metal plate. When the circuit was energized, De Forest found that the ammeter stayed on zero regardless of the polarity of the input signal.

NEETS MODULE 6-Electronic Emission, Tubes, and Power Supplies UNCLASSIFIED

What was happening was that the new element was blocking (or shadowing) the plate. Any electrons attempting to reach the plate from the cathode would hit the new element instead. As the circuit didn't work, it was back to the drawing board.

In his next attempt, De Forest decided to change the element between the cathode and the plate. Instead of a solid metal plate, he used a wire mesh. This would allow electrons to flow from the cathode, **THROUGH THE WIRE MESH**, to the plate. This tube circuit is shown in figure 1-15. In view (A) you see De Forest's circuit with 0 volts applied to the third element, (today called a control grid or occasionally just the grid). Under these conditions, assume that the ammeter reads 5 milliamperes. With no voltage applied to the grid, the grid has little effect on the electron stream. For all practical purposes, the control grid is not there. Most electrons flow through the open mesh. The tube functions as a diode.

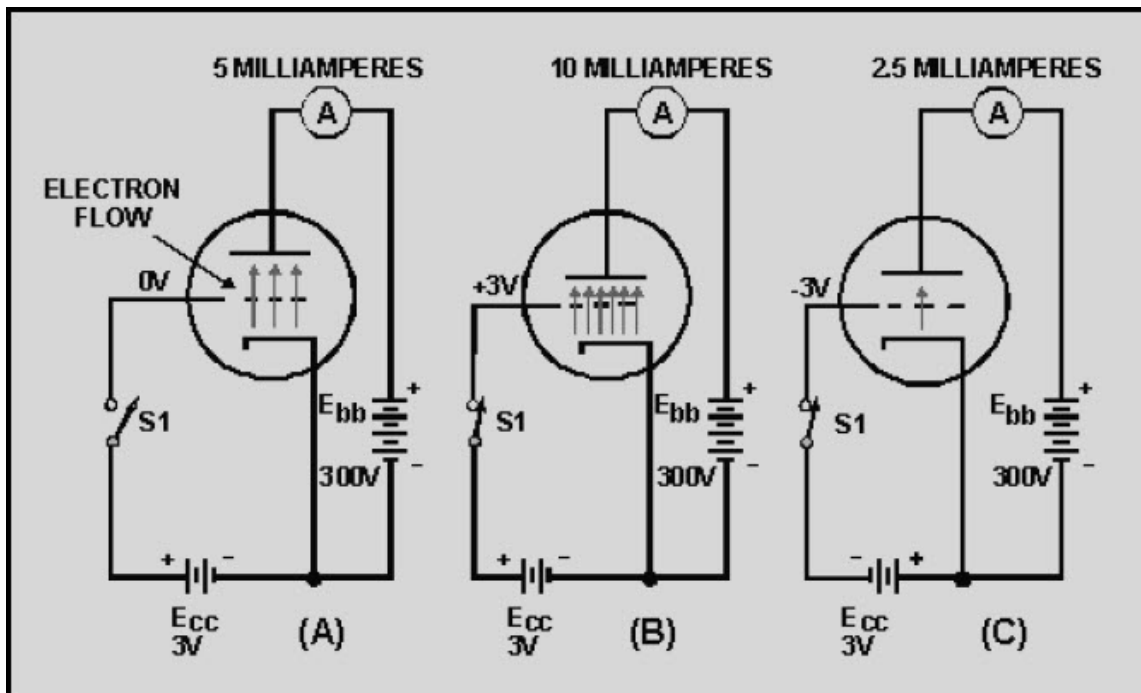

Figure 1-15 DeForest's experiment

NEETS MODULE 6-Electronic Emission, Tubes, and Power Supplies

UNCLASSIFIED

In view (B), you see De Forest's tube with +3 volts applied to the control grid. When De Forest applied this voltage, he found that plate current, I_p , increased by a large amount. (We'll say it doubled to simplify the explanation.) You already know that the only way to double the plate current in a diode is to increase the plate voltage by a large amount. Yet, De Forest had doubled plate current by applying only 3 volts positive to the control grid!

The reason for this is fairly easy to understand. It's the old principle of "opposites attract." When the control grid was made positive, electrons surrounding the cathode (negative charges) were attracted to the grid. But remember, the grid is a metal mesh. Most of the electrons, instead of striking the grid wires, were propelled through the holes in the mesh. Once they had passed the grid, they were attracted to the positive charge in the plate.

You might wonder why the grid would make that much difference. After all, the plate has 300 volts on it, while the grid only has 3 volts on it. Surely the plate would have a greater effect on current flow than a grid with only one one-hundredth the attractive potential of the plate. But remember, in your study of capacitors you discovered that opposites attract because of electrostatic lines of force, and that the strength of electrostatic lines of force decreased with distance. In his tube, DeForest had placed the grid very close to the cathode. Therefore, it had a greater effect on current flow from the cathode than did the plate, which was placed at a much greater distance from the cathode. For this reason, De Forest was able to double the current flow through the tube with only +3 volts applied to the grid.

DeForest had certainly hit on something. Now the problem was to find out what would happen when a negative potential was applied to the grid. This is shown in view (C) of figure 1-15. When De Forest applied -3 volts to the grid, he found that plate current decreased to half of what it was when the grid had no voltage applied. The reason for this is found in the principle of "likes repel." The negatively charged grid simply repelled some of the electrons back toward the cathode. In this manner, the attractive effect of the plate was decreased, and less current flowed to the plate.

Now De Forest was getting somewhere. Using his new tube (which he called a triode because it had 3 elements in it), he was able to control relatively large changes of current with very small voltages. But was it amplification? Remember, amplification is the process of taking a small signal and increasing its amplitude. In De Forest's circuit, the small input signal was 3 volts dc. What De Forest got for an output was a variation in plate current of 7.5 milliamperes. Instead of amplification, De Forest had obtained "conversion," or in other words, converted a signal voltage to a current variation. This wasn't exactly what he had in mind. As it stood, the circuit wasn't very useful. Obviously, something was needed. After examining the circuit, De Forest discovered the answer - Ohm's law. Remember $E = I \times R$? De Forest wanted a voltage change, not a current change.

NEETS MODULE 6-Electronic Emission, Tubes, and Power Supplies UNCLASSIFIED

The answer was simple:

$$\begin{array}{ccccccc} \text{If you want} & & \text{and you have} & & \text{simply add} & & \\ E & = & I & \times & R & & \end{array}$$

In other words, run the plate current variation (caused by the voltage on the grid) through a resistor, and cause a varying voltage drop across the resistor. This is shown in figure 1-16.

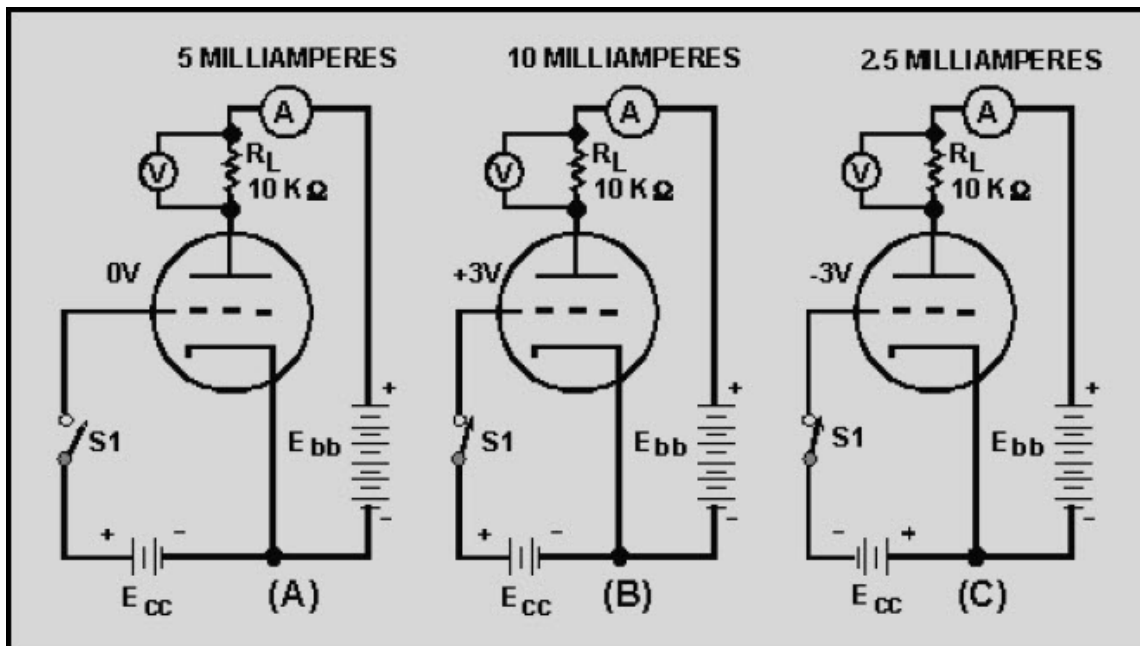

Figure 1-16 Operation of the plate load resistor

The circuit is identical to the one in figure 1-15 except that now a resistor (called a plate-load resistor, R_L) has been added to the plate circuit, and a voltmeter has been added to measure the voltage drop across R_L .

NEETS MODULE 6-Electronic Emission, Tubes, and Power Supplies UNCLASSIFIED

In view (A) of figure 1-16, the control grid is at 0 volts. Once again 5 milliamperes flow in the plate circuit. Now, the 5 milliamperes must flow through R_L . The voltage drop is equal to:

$$E = I \times R$$

$$E = (5 \times 10^{-3} \text{ amperes}) \times (10 \times 10^3 \text{ ohms})$$

$$E = (5 \times 10^{-3}) \times (10 \times 10^3)$$

$$E = 5 \times 10$$

$$E = 50 \text{ volts}$$

Thus the voltage drop across the plate-load resistor, R_L , is 50 volts when no voltage is applied to the grid. In view (B) of the figure, +3 volts is applied to the control grid. Once again plate current increases to 10 milliamperes. The voltage drop across R_L is

$$E = I \times R$$

$$E = (10 \times 10^{-3} \text{ amperes}) \times (10 \times 10^3 \text{ ohms})$$

$$E = (10 \times 10^{-3}) \times (10 \times 10^3)$$

$$E = 10 \times 10$$

$$E = 100 \text{ volts}$$

By applying +3 volts to the grid, the voltage drop across R_L was increased by 50 volts (from the original 50 volts to 100 volts). In view (C), -3 volts has once again been applied to the control grid. Once again plate current decreases to 2.5 milliamperes and the voltage drop across R_L drops to 25 volts.

We have caused the voltage across R_L to vary by varying the grid voltage; but is it amplification? Well, let's take a look at it. The grid voltage, or input signal, varies from +3 to -3 volts, or 6 volts. The voltage drop across R_L varies from 25 volts to 100 volts, or 75 volts. In other words, the triode has caused a 6-volt input signal (varying) to be outputted as a signal that varies by 75 volts. That's amplification!

NEETS MODULE 6-Electronic Emission, Tubes, and Power Supplies
UNCLASSIFIED

Q13. What is the primary difference between a diode and a triode?

Q14. Why does the grid have a greater effect than the plate on electron flow through a vacuum tube?

Q15. What component is used in a triode amplifier to convert variation in current flow to voltage variation?

Let's summarize what you have learned so far:

- A relatively small change in voltage on the grid causes a relatively large change in plate current.
- By adding a plate-load resistor in series with the plate circuit, the changing plate current causes a changing voltage drop in the plate circuit.
- Therefore, the small voltage change on the grid causes a large change of voltage in the plate circuit.
- By this process, the small input signal on the grid has been amplified to a large output signal voltage in the plate circuit.

We'll leave De Forest at this point. He showed that the control grid can, in fact, **CONTROL** plate current. He also showed that the changing plate current can create a changing plate voltage. To some degree, his changing voltages and currents also changed the world.

NEETS MODULE 6-Electronic Emission, Tubes, and Power Supplies

UNCLASSIFIED

1.4.1 Introduction to Grid Bias

We purposely left out several features of practical triode circuits from the circuits we just discussed. We did so to present the idea of grid control more simply. One of these features is grid bias.

Let's take another look at the circuit in figure 1-15(B). We found that the positive charge on the grid caused more plate current to flow. However, when the grid becomes positive, it begins to act like a small plate. It draws a few electrons from the space charge. These electrons flow from the cathode across the gap to the positive grid, and back through the external grid circuit to the cathode. This flow is known as *grid current*. In some tube applications, grid current is desired. In others it is relatively harmless, while in some, grid current causes problems and must be eliminated.

Most amplifier circuits are designed to operate with the grid **NEGATIVE** relative to the cathode. The voltage that causes this is called a **BIAS VOLTAGE**. The symbol for the bias supply is E_{cc} . One effect of bias (there are several other very important ones) is to reduce or eliminate grid current. Let's see how it works.

GRID BIAS is a steady, direct voltage that is placed at some point in the external circuit between the grid and the cathode. It may be in the cathode leg or the grid leg as shown in figure 1-17. It is always in series with the input signal voltage. In each of the circuits in figure 1-17, E_{cc} makes the grid negative with respect to the cathode because of the negative terminal being connected toward the grid and the positive terminal being connected toward the cathode. With identical components, each circuit would provide the same bias.

NEETS MODULE 6-Electronic Emission, Tubes, and Power Supplies
UNCLASSIFIED

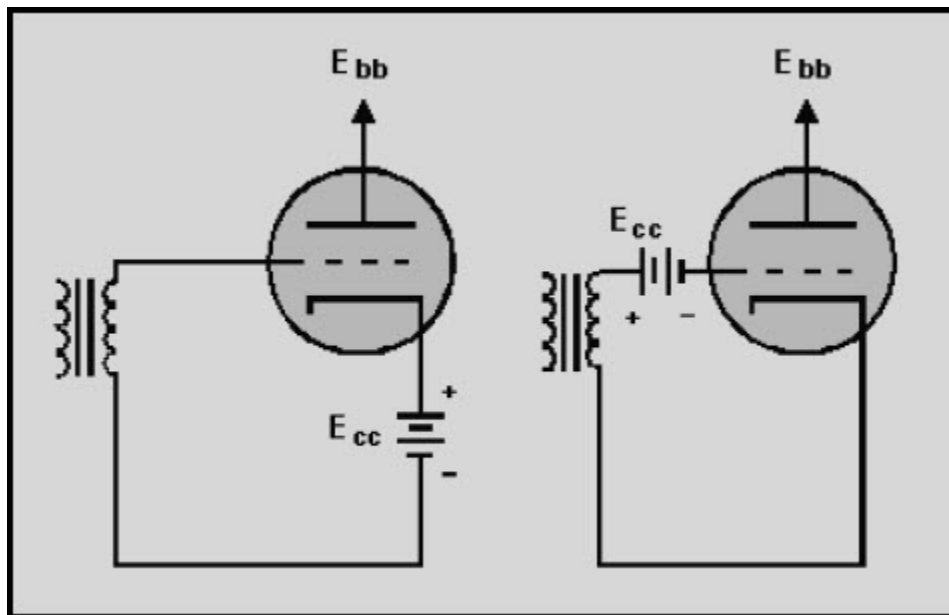

Figure 1-17 Basic biasing of a triode

NEETS MODULE 6-Electronic Emission, Tubes, and Power Supplies UNCLASSIFIED

Battery bias is practically never used in modern circuits. Because of its simplicity, however, we will use it in analyzing the effects of bias. We will present other, more practical methods later.

Let's assume that the bias voltage in figure 1-17 is -6 volts. Let's also assume that the peak-to-peak signal voltage from the transformer is 6 volts. Each of these voltage waveforms is shown in figure 1-18. From past experience you know that voltages in series **ADD**. Figure 1-18 has a table of the instantaneous values of the two voltages added together. The waveforms are drawn from these values.

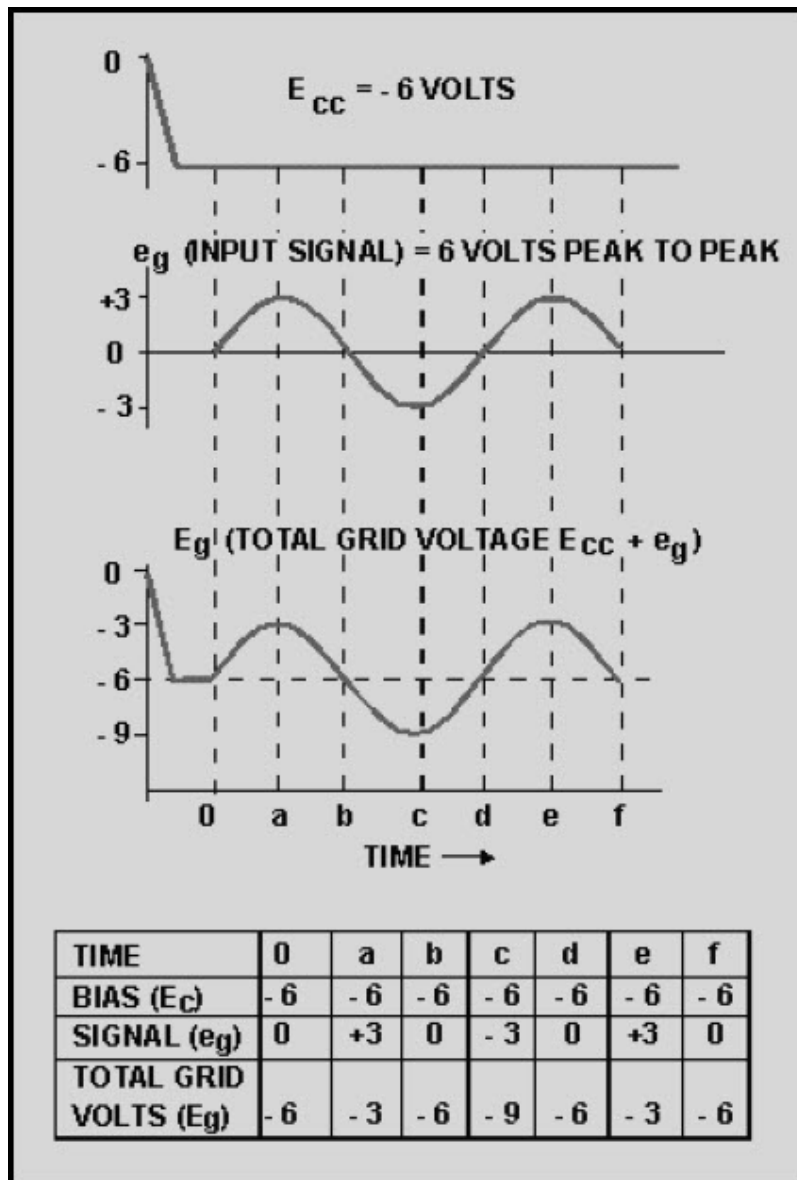

Figure 1-18 Typical grid waveforms

NEETS MODULE 6-Electronic Emission, Tubes, and Power Supplies

UNCLASSIFIED

Because the bias voltage is more negative than the signal voltage is positive, the resultant voltage (bias plus signal), E_g , is **ALWAYS** negative. The signal, in this case, makes the grid voltage go either **MORE** or **LESS NEGATIVE**, (-9 to -3) but cannot drive it positive.

Under these circumstances, the negative grid always repels electrons from the space charge. The grid cannot draw current. Any problems associated with grid current are eliminated, because grid current cannot flow to a negative grid.

You have probably already realized that the negative bias also reduces plate current flow. (Negative charge on grid-less plate current, right?) The trick here is for the circuit designer to choose a bias and an input signal that, when added together, do not allow the grid to become positive nor to become negative enough to stop plate current.

Tube biasing is very important. You will learn much more about it shortly. From this brief introduction, you should have learned that grid bias

- is a steady, direct voltage that in most cases makes the grid negative with respect to the cathode;
- is in series with the signal voltage between grid and cathode;
- acts to reduce or eliminate grid current;
- acts to reduce plate current from what it would be if no bias existed;
- is produced in other ways than just by a battery; and
- is important for reasons other than those just studied.

NEETS MODULE 6-Electronic Emission, Tubes, and Power Supplies UNCLASSIFIED

1.4.2 Operation of the Triode

The circuit in figure 1-19 brings together all of the essential components of a triode amplifier. Before analyzing the circuit, however, we need to define the term **QUIESCENT**.

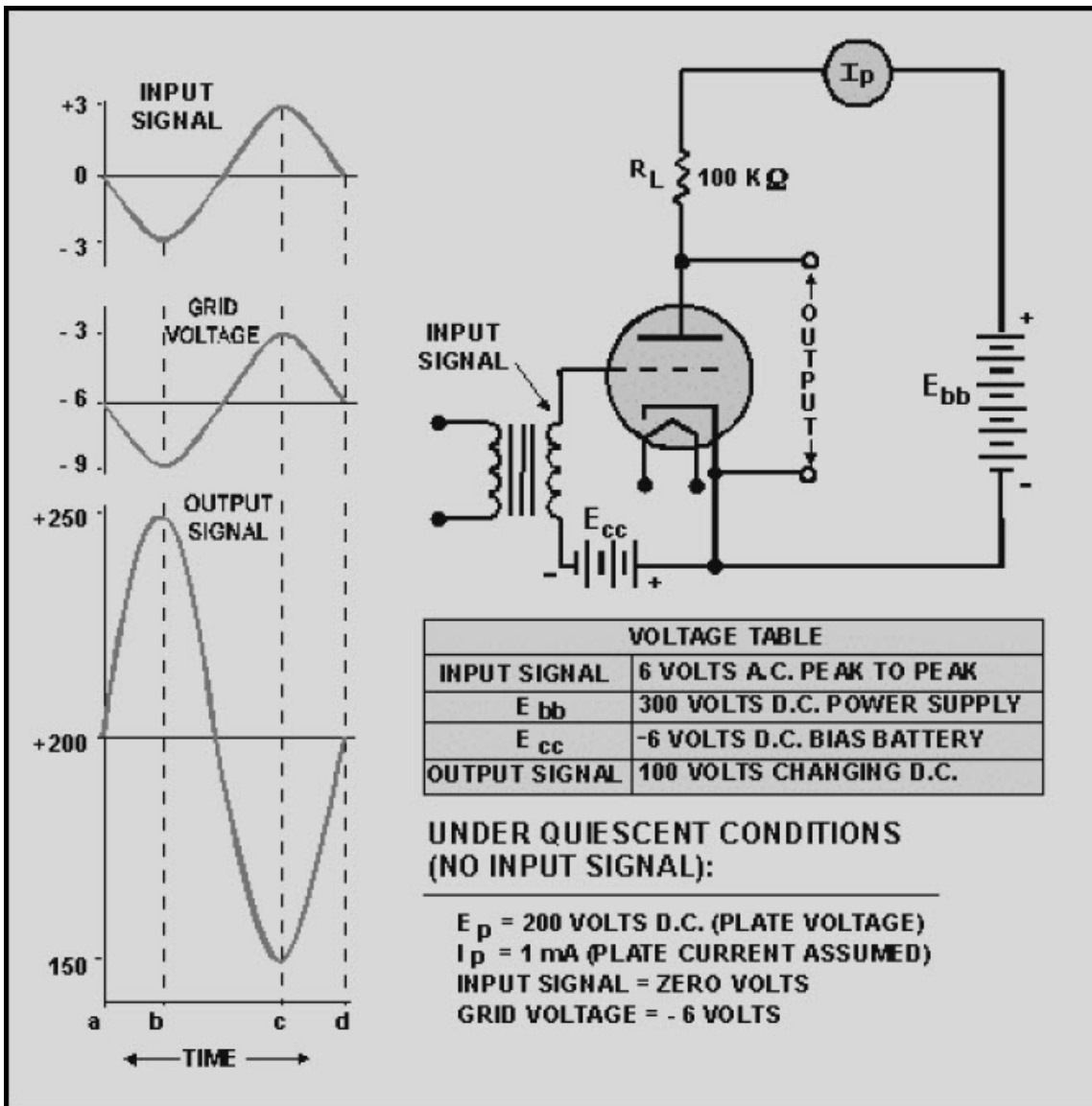

Figure 1-19 Triode operation

NEETS MODULE 6-Electronic Emission, Tubes, and Power Supplies UNCLASSIFIED

The term *quiescent* identifies the condition of a circuit with **NO INPUT SIGNAL** applied. With a given tube, bias supply, and plate supply, an exact amount of plate current will flow with no signal on the grid. This amount is known as the quiescent value of plate current. The quiescent value of plate voltage is the voltage between cathode and plate when quiescent current flows.

Simply, quiescent describes circuit conditions when the tube is not amplifying. The tube has no output signal and is in a kind of standby, waiting condition. Now let's go on to figure 1-19. With no input signal, under quiescent conditions, assume that 1 milliampere of current flows through the tube, cathode to plate. This current (I_p) will flow through R_L (load resistor) to the positive terminal of the battery. The current flowing through R_L causes a voltage drop (IR) across R_L equal to:

$$E = I_p \times R_L$$

$$E = 1 \times 10^3 \text{ amperes} \times 100 \times 10^3 \text{ ohms}$$

$$E = 100 \text{ volts}$$

Subtracting the voltage dropped across the plate-load resistor from the source voltage of 300 volts gives you 200 volts (300 volts - 100 volts). Thus, the plate voltage (E_p) is at 200 volts. The quiescent conditions for the circuit are:

$$\text{grid voltage} = -6 \text{ volts}$$

$$\text{plate voltage } (E_p) = +200 \text{ volts}$$

These values are shown on the waveforms as time a in figure 1-19.

You should notice that even though the grid is more negative (-6 volts) than the cathode, the tube in the circuit is still conducting, but not as heavily as it would if the grid were at zero volts.

Now look at the input signal from the transformer secondary. For ease of explanation, we will consider only three points of the ac sine wave input: point b, the maximum negative excursion; point c, the maximum positive excursion; and point d, the zero reference or null point of the signal. At time b, the input signal at the grid will be at its most negative value (-3 volts). This will cause the grid to go to -9 volts (-6 volts + -3 volts). This is shown at time b on the grid voltage waveform. The increased negative voltage on the control grid will decrease the electrostatic attraction between the plate and the cathode. Conduction through the tube (I_p) will decrease. Assume that it drops to .5 milliamperes.

NEETS MODULE 6-Electronic Emission, Tubes, and Power Supplies UNCLASSIFIED

The decrease in plate current will cause the voltage drop across the plate-load resistor (R_L) to also decrease from 100 volts, as explained by Ohm's law:

$$E = I_p \times R_L$$

$$E = .0005 \text{ amperes} \times 100,000 \text{ ohms}$$

or

$$E = (.5 \times 10^{-3} \text{ amperes}) \times (100 \times 10^3 \text{ ohms})$$

$$E = 50 \text{ volts}$$

Plate voltage will then rise +250 volts.

$$E_p = 300 \text{ volts} - 50 \text{ volts} = 250 \text{ volts}$$

This is shown on the output signal waveform at time b.

At time c, the input has reached its maximum positive value of +3 volts. This will decrease grid voltage to -3 volts (-6 volts + 3 volts). This is shown on the grid voltage waveform at time c. This in turn will increase the electrostatic force between the plate and cathode. More electrons will then flow from the cathode, through the grid, to the plate. Assume that the plate current in this case will increase to 1.5 milliamperes. This will cause plate voltage (E_b) to decrease to 150 volts as shown below.

$$E = I_p \times R_L$$

$$E = (1.5 \times 10^{-3} \text{ amperes}) \times (100 \times 10^3 \text{ ohms})$$

$$E = 150 \text{ volts}$$

$$E_p = 300 \text{ volts} - 150 \text{ volts}$$

$$E_p = 150 \text{ volts}$$

This is shown on the output waveform at time c.

NEETS MODULE 6-Electronic Emission, Tubes, and Power Supplies UNCLASSIFIED

At time d, the input signal voltage decreases back to zero volts. The grid will return to the quiescent state of -6 volts, and conduction through the tube will again be at 1 milliamperes. The plate will return to its quiescent voltage of +200 volts (shown at time d on the output waveform).

As you can see, varying the grid by only 6 volts has caused the output of the triode to vary by 100 volts. The input signal voltage has been amplified (or increased) by a factor of 16.6. This factor is an expression of amplifier **VOLTAGE GAIN** and is calculated by dividing the output signal voltage by the input signal voltage.

Before going on to the next section, there is one more thing of which you should be aware. Look again at the waveforms of figure 1-19. Notice that the output voltage of the amplifier is 180° out of phase with the input voltage. You will find that this polarity inversion is a characteristic of any amplifier in which the output is taken between the cathode and the plate. This is normal and should not confuse you when you troubleshoot or work with this type of circuit.

Q16. Why is the control grid of a triode amplifier negatively biased?

Q17. For a circuit to be considered to be in the quiescent condition, what normal operating voltage must be zero?

Q18. A triode amplifier similar to the one shown in figure 1-19 has an E_{bb} -350 volts dc. The plate-load resistor is 50 k Ω . Under quiescent conditions, 1.5 milliamperes of current conducts through the tube. What will be the plate voltage (E_p) under quiescent conditions?

NEETS MODULE 6-Electronic Emission, Tubes, and Power Supplies

UNCLASSIFIED

Q19. A 2-volt, peak-to-peak, ac input signal is applied to the input of the circuit described in Q18. When the signal is at its maximum positive value, 2.5 milliamperes flows through the tube. When the input is at its maximum negative value, conduction through the tube decreases to .5milliamperes.

- a. What is the peak-to-peak voltage of the output signal?*

- b. What is the phase relationship between the input and output signals?*

1.4.3 Factors Affecting Triode Operation

The triode circuit you have just studied is a fairly simple affair. In actual application, triode circuits are a bit more complex. There are two reasons for this. The first has to do with the triodes ability to amplify and perform other functions. Triodes come in many different types. Each of these types has different internal characteristics and different capabilities. Because of this, each triode circuit must be designed to accommodate the triodes special characteristics. The second reason for the increase in complexity has to do with **DISTORTION**. Distortion occurs in a tube circuit any time the output waveform is not a faithful reproduction of the input waveform.

Polarity inversion and voltage gain of the output waveform are not included in this definition of distortion. Some circuits are designed to distort the output. The reason and methods for this deliberate distortion will be covered in a later *NEETS* module. For the most part, however, we desire that circuits eliminate or reduce distortion.

Because the grid is close to the cathode, small changes in grid voltage have large effects on the conduction of triodes. If a large enough input signal is placed on the grid, a triode may be driven into either plate-current cutoff or plate-current saturation. When this occurs, the tube is said to be **OVERDRIVEN**. Overdriving is considered to be a form of **DISTORTION**.

NEETS MODULE 6-Electronic Emission, Tubes, and Power Supplies UNCLASSIFIED

Look at time zero (0) in the waveforms of figure 1-20. The input signal (E_{in}) is at zero volts. Grid voltage equals the bias voltage (-6 volts), and one milliampere of current is flowing through the tube (quiescent state). Plate voltage (E_p) is 200 volts.

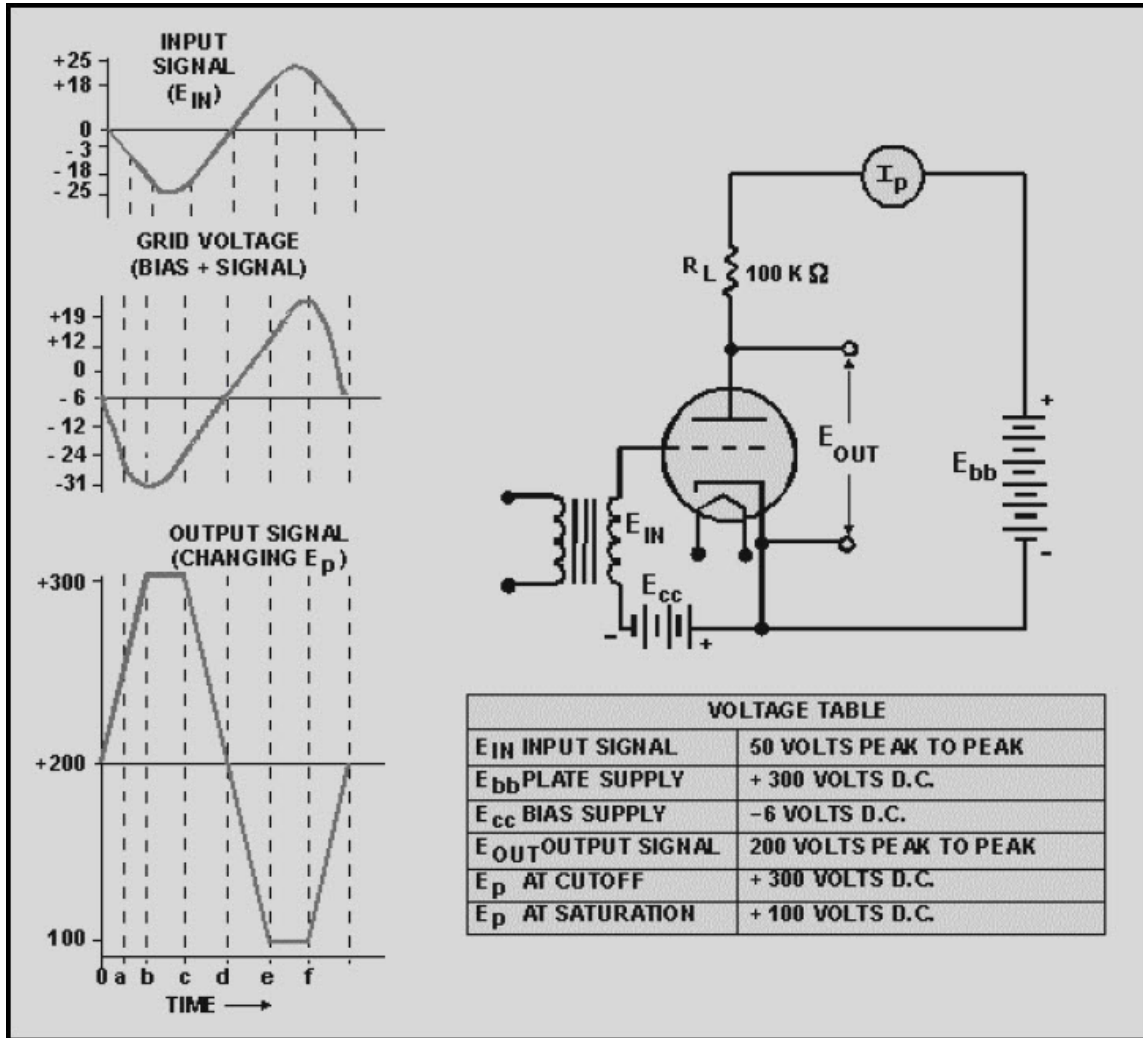

Figure 1-20 Overdriven triode

On the negative half of the input signal, the grid voltage is made more negative. This reduces plate current which, in turn, reduces the voltage drop across R_L . The voltage between cathode and the plate is thereby increased. You can see these relationships by following time "a" through the three waveforms.

NEETS MODULE 6-Electronic Emission, Tubes, and Power Supplies

UNCLASSIFIED

Now, let's assume that this particular triode cuts plate current flow off when the grid reaches -24 volts. This point is reached at time b when E_{in} is -18 and the bias is -6 (-18 and -6 = -24). Plate current remains cut off for as long as the grid is at -24 volts or greater.

With zero current flowing in the plate circuit, there is no voltage drop across R_L . The entire plate-supply voltage, E_{bb} (300 volts), appears as plate voltage between the cathode and the plate. This is shown at time b in the output signal waveform. Between time b and time c, the grid voltage is greater than -24 volts. The plate current remains cutoff, and the plate voltage remains at +300. The output waveform between time b and time c cannot follow the input because the plate voltage cannot increase above +300 volts. The output waveform is "flat-topped." This condition is known as **AMPLITUDE DISTORTION**.

When the grid voltage becomes less negative than -24 volts, after time c, the tube starts conducting, and the circuit again produces an output.

Between time c and time d, the circuit continues to operate without distortion. At time e, however, the output waveform is again distorted and remains distorted until time f. Let's see what happened.

Remember that every cathode is able to emit just so many electrons. When that maximum number is being emitted, the tube is said to be at **SATURATION** or **PLATE SATURATION**. Saturation is reached in a triode when the voltages on the grid and plate combine to draw all the electrons from the space charge.

Now, as our grid becomes less negative (between time c and time d), and actually becomes positive (between time d and time e), the plate current increases, the voltage across R_L increases, and the plate voltage decreases.

Apparently when the grid voltage reached +12 volts at time e, the plate current reached saturation. Maximum plate current (at saturation) results in maximum voltage across R_L and minimum plate voltage. Any grid voltage higher than +12 volts cannot cause further changes in the output. Therefore, between time e and time f, the plate voltage remains at +100 volts and the waveform is distorted. This is also **AMPLITUDE DISTORTION**.

NEETS MODULE 6-Electronic Emission, Tubes, and Power Supplies UNCLASSIFIED

This has been an explanation of one cycle of an input signal that overdrives the tube. You should notice that, using the same circuit, a 50-volt peak-to-peak input signal caused a vastly different output from that caused by the 6-volt peak-to-peak input signal. The 6-volt peak-to-peak signal did not overdrive the tube. When the input signal was increased to 50-volts peak-to-peak, the tube was forced into cutoff when the grid was driven to -24 volts, and into saturation when the grid was driven to +12 volts (the grid voltage plus the signal voltage.) During these periods, the tube could not respond to the input signal. In other words, the output was distorted. A method commonly used to partially overcome distortion is to vary the bias voltage on the grid. The point at which the tube goes into cutoff or saturation can then be controlled.

For this reason tube biasing is of great importance in most tube circuits.

Q20. The waveforms shown below are the input and output of an overdriven triode

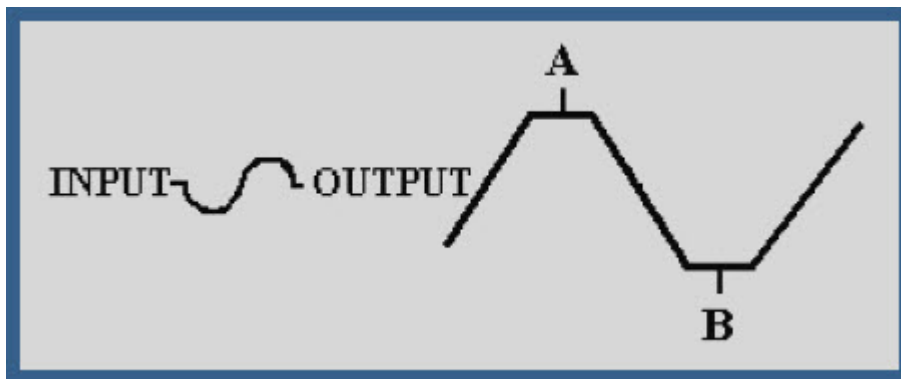

a. Distortion A at the output is the result of what condition?

b. Distortion B at the output is the result of what condition?

NEETS MODULE 6-Electronic Emission, Tubes, and Power Supplies

UNCLASSIFIED

1.4.4 Types of Biasing

There are two main classes of biasing - **FIXED** and **SELF**. In a tube circuit that uses fixed bias, the grid-bias voltage is supplied from a power source external to the circuit. You are already familiar with battery bias, which is one form of fixed bias. When fixed bias is used in a circuit, it can be represented as either a battery (fig. 1-21, view A), or as a conductor connected to $-E_{cc}$ (fig. 1-21, view B). Fixed bias is rarely used in electronics today. Therefore, we will not discuss it further.

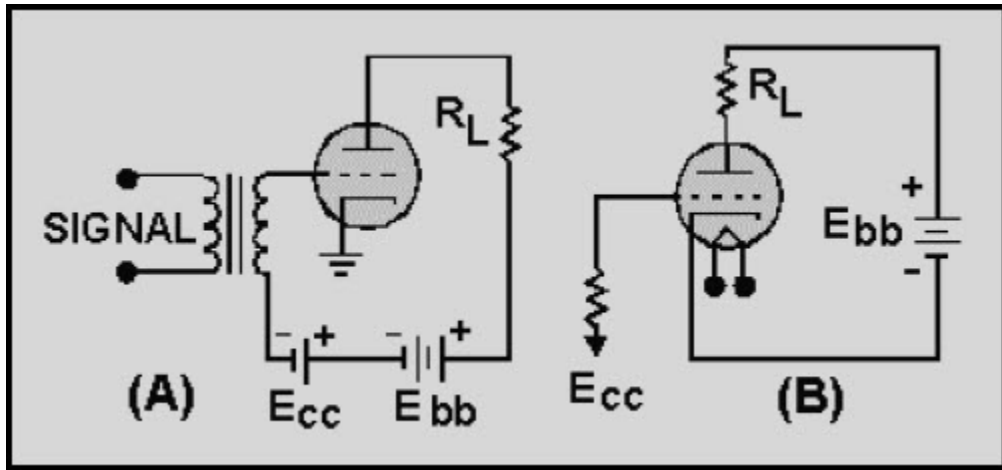

Figure 1-21 Fixed bias: A. Battery B. Conductor

In circuits using self-bias, the bias voltage is developed across a resistor in the cathode or grid circuit by tube current. There are two main methods of self-bias: *cathode biasing* and *grid-leak biasing*.

NEETS MODULE 6-Electronic Emission, Tubes, and Power Supplies

UNCLASSIFIED

1.4.4.1 Cathode Bias

In circuits using cathode bias, the cathode is made to go positive relative to the grid. The effect of this is the same as making the grid negative relative to the cathode. Because the biasing resistor is in the cathode leg of the circuit, the method is called **CATHODE BIASING** or **CATHODE BIAS**. A triode circuit using cathode bias is shown in figure 1-22.

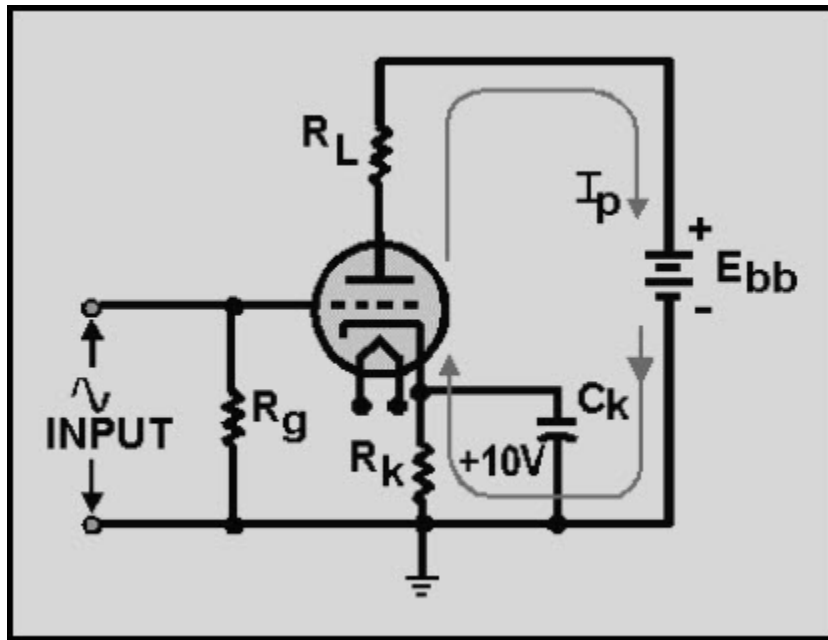

Figure 1-22 Cathode bias

The only difference between the illustrated circuit and the one used to demonstrate triode operation is the elimination of the battery, E_{cc} , and the addition of circuit components R_k , the cathode-biasing resistor; C_k , the cathode ac-bypass capacitor; and a grid resistor (whose purpose will be explained later).

When the tube conducts, current flows from the battery through R_k to the cathode, through the tube to the plate, and through R_L to the positive terminal of the battery. The current flowing through R_k will cause a voltage drop across R_k . The bottom of R_k goes negative while the top goes positive. This positive voltage at the top of R_k makes the cathode positive relative to the grid.

NEETS MODULE 6-Electronic Emission, Tubes, and Power Supplies

UNCLASSIFIED

You may wonder what purpose C_k serves in this circuit. C_k serves as an **AC BYPASS**. Without C_k , the bias voltage will vary with ac input signals. This is particularly troublesome in the higher frequencies like those found in radio receivers. R_k , the cathode-biasing resistor, is used to develop the biasing voltage on the cathode.

The input signal will be developed across R_g . You will read more about the circuit component later in this chapter. Cathode-biasing voltage is developed in the following manner.

As we mentioned earlier, the bias voltage will vary with the input unless C_k , the cathode bypass capacitor, is used.

To understand how the bias voltage will vary with an ac input signal, disregard C_k for the moment and refer to figure 1-22 again.

Notice that under quiescent conditions, the voltage drop at the top of R_k is +10 volts. Now let's apply the positive-going signal illustrated to the left of the tube. When the positive signal is applied, conduction through the tube will increase. The only trouble is that current through R_k will also increase. This will increase the voltage drop across R_k , and the cathode voltage will now be greater than +10 volts. Remember, at this time the plate is going negative due to increased conduction through the tube. The combination of the negative-going plate and the positive-going cathode will decrease the electrostatic attraction across the tube and lower the conduction of the tube. This will reduce the gain of the tube.

When the negative-going signal is applied, conduction through the tube decreases. Current through R_k decreases and the voltage drop across R_k decreases. This causes the cathode to go more negative, which tends to increase conduction through the tube. A negative-going signal is amplified by decreasing plate current and allowing the plate to go positive (remember the 180° inversion.) Thus, increasing conduction on the negative half-cycle decreases the gain of that half-cycle. The overall effect of allowing cathode biasing to follow the input signal is to decrease the gain of the circuit with ac inputs.

This problem can be overcome by installing C_k . The purpose of C_k is to maintain the cathode bias voltage at a constant level. In common usage, the action of C_k is referred to as "bypassing the ac signal to ground."

The action of C_k will be explained using figure 1-23. View A shows the circuit under quiescent conditions. With some conduction through the tube, the cathode and the tops of R_k and C_k are at +10 volts.

**NEETS MODULE 6-Electronic Emission, Tubes, and Power Supplies
UNCLASSIFIED**

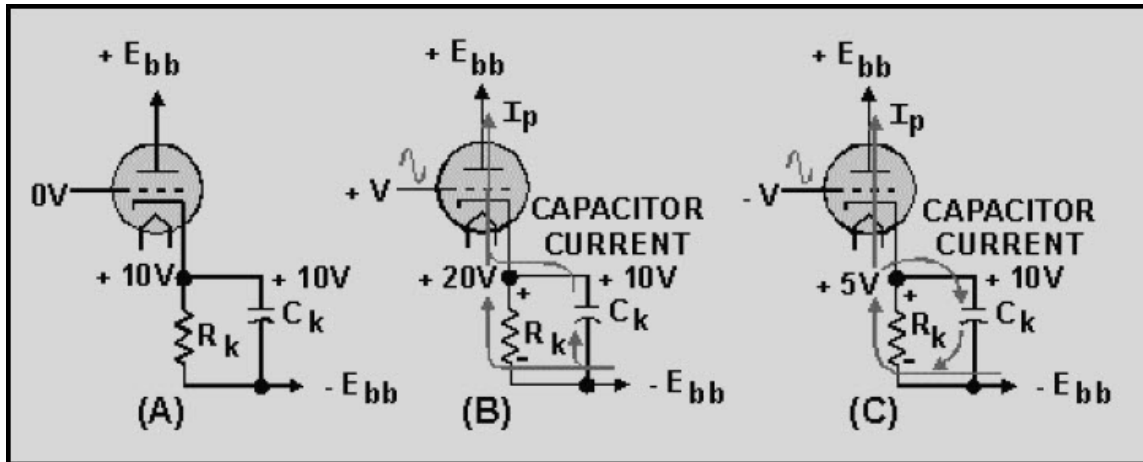

Figure 1-23 Effect of the bypass capacitor

In view B, the positive-going signal is applied to the grid. This causes increased conduction through the tube, which attempts to drive the cathode to +20 volts. But notice that the top of C_k is still at +10 volts (remember capacitors oppose a change in voltage). The top plate of C_k is, in effect, 10 volts negative in relation to the top of R_k . The only way that C_k can follow the signal on the top of R_k (+20 volts) is to charge through the tube back to the source, from the source to the lower plate of C_k . When C_k charges through the tube, it acts as the source of current for the cathode. This causes the cathode to remain at +10 volts while the capacitor is charging.

View C of the figure shows the same signal. Under these conditions, conduction through R_k will decrease. This will cause a decrease in current flow through R_k . Decreased current means decreased voltage drop. The top of R_k will try to go to +5 volts. C_k must now go more negative to follow the top of R_k . To do this, current must flow from C_k through R_k , to the top plate of C_k . This discharging of C_k will increase current flow through R_k and increase the voltage drop across R_k , forcing the top to go more positive. Remember, the voltage drop is due to current flow through the resistor. (The resistor could care less if the current is caused by conduction or capacitor action.) Thus, the cathode stays at +10 volts throughout the capacitor-charge cycle.

There is one point that we should make. C_k and R_k are in parallel. You learned from previous study that voltage in a parallel circuit is constant. Thus, it would seem impossible to have the top of R_k at one voltage while the top plate of C_k is at another. Remember, in electronics nothing happens instantaneously. There is always some time lag that may be measured in millionths or billionths of seconds. The action of C_k and R_k that was just described takes place within this time lag. To clarify the explanation, the voltages used at the components R_k and C_k were exaggerated. Long before a 10-volt differential could exist between the tops of R_k and C_k , C_k will act to eliminate this voltage differential.

NEETS MODULE 6-Electronic Emission, Tubes, and Power Supplies

UNCLASSIFIED

The capacitor, then, can be said to regulate the current flow through the bias resistor. This action is considered as **BYPASSING** or eliminating the effect of the ac input signal in the cathode. For all practical purposes, you can assume that ac flows through the capacitor to ground. But, remember, ac only appears to flow across a capacitor. In reality the ac signal is shunted around the capacitor.

There are two disadvantages associated with cathode biasing. To maintain bias voltage continuously, current must flow through the tube, and plate voltage will never be able to reach the maximum value of the source voltage. This, in turn, limits the maximum positive output for a negative input signal (remember the 180° inversion). In addition, maximum plate voltage is decreased by the amount of cathode-biasing voltage. What this means is that you can't get something for nothing. If the cathode is biased at +20 volts, this voltage must be subtracted from the plate voltage. As an example, consider a triode with a 10,000 ohm plate resistor and a +300 volts dc source voltage. If a current of 2 milliamperes flows through the tube under quiescent conditions, 20 volts are dropped across the plate-load resistor. The maximum plate voltage is then 300 volts - 20 volts = 280 volts dc. Now, consider the 20-volt dropped across the cathode resistor. Plate voltage becomes 280 volts - 20 volts = 260 volts. To understand this a little more thoroughly, look at figure 1-24. In view A, the source voltage is 300 volts dc. There are two ways that this voltage can be looked at; either the plate is at +300 volts and the cathode is at 0 volts (ground), or the plate is at +150 volts and the cathode is at -150 volts. In electronics, it is common practice to assume that the plate is at +300 volts while the cathode is at 0 volts. To simplify this discussion, we will assume that the plate is at +150 volts, and the cathode is at -150 volts. The potential difference between the plate and the cathode is 300 volts. If a plate-load resistor is installed, as shown in view B, 20 volts are dropped by R_L . The potential difference between the plate and the cathode is now 280 volts. In view C, R_k has now been placed in the same circuit. R_k drops 20 volts. Therefore, the effect of cathode biasing is to reduce the maximum positive signal that the circuit can produce. In this case, the maximum positive signal has been reduced by 20 volts. Despite these disadvantages, cathode biasing has two main advantages. It is simple and economical.

NEETS MODULE 6-Electronic Emission, Tubes, and Power Supplies
UNCLASSIFIED

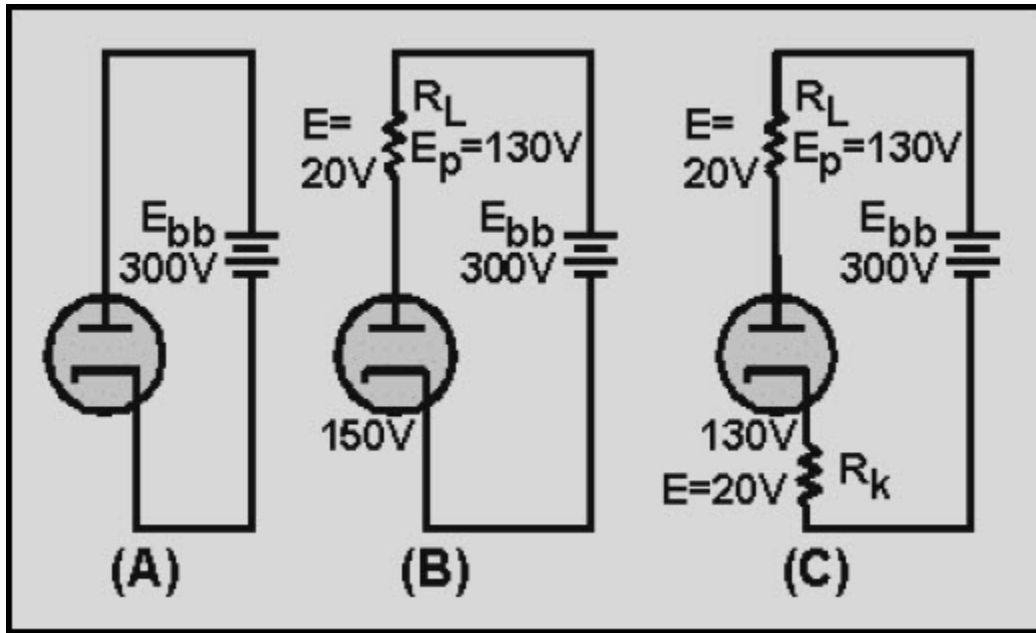

Figure 1-24 Loss due to cathode biasing

1.4.4.2 Grid-Leak Biasing

The second type of self-biasing to be discussed is **GRID-LEAK BIAS**. As the name implies, bias voltage is developed in the grid leg portion of the circuit. Bias voltage in this type of biasing is derived by allowing the positive input signal to draw grid current through a circuit made up of a resistor and a capacitor. There are two types of grid-leak bias commonly in use: **SHUNT TYPE** and **SERIES TYPE**. Because shunt type grid-leak biasing is the simplest, we will discuss it first. Figure 1-25 depicts a simplified triode circuit using the shunt-type grid-leak biasing. Before we begin the explanation of shunt grid-leak biasing, there is one thing you should bear in mind. Because the bias is derived from the positive input signal through capacitive action, the input signal must go through several positive alternations before the final operating bias voltage is achieved. We will explain why this is so in the following discussion.

NEETS MODULE 6-Electronic Emission, Tubes, and Power Supplies
UNCLASSIFIED

View A of figure 1-25 shows the circuit under quiescent conditions. You will notice that the circuit is similar to the one we used to explain the action of a triode. The only additions are the grid resistor, R_g , coupling capacitor, C_c , and resistance rgk . Resistance rgk doesn't exist as a physical component, but it is used to represent the internal tube resistance between the triode's cathode and grid. Electrically, rgk is quite small, about 500 ohms. Under quiescent conditions, some conduction occurs through the tube. Some electrons will strike the wires of the grid, and a small amount of **GRID CURRENT** will flow through R_g to ground. This will cause the right-hand plate of C_c to go slightly negative. This slight negative charge will, in turn, keep the grid of the tube slightly negative. This limits the number of electrons that strike the grid wires.

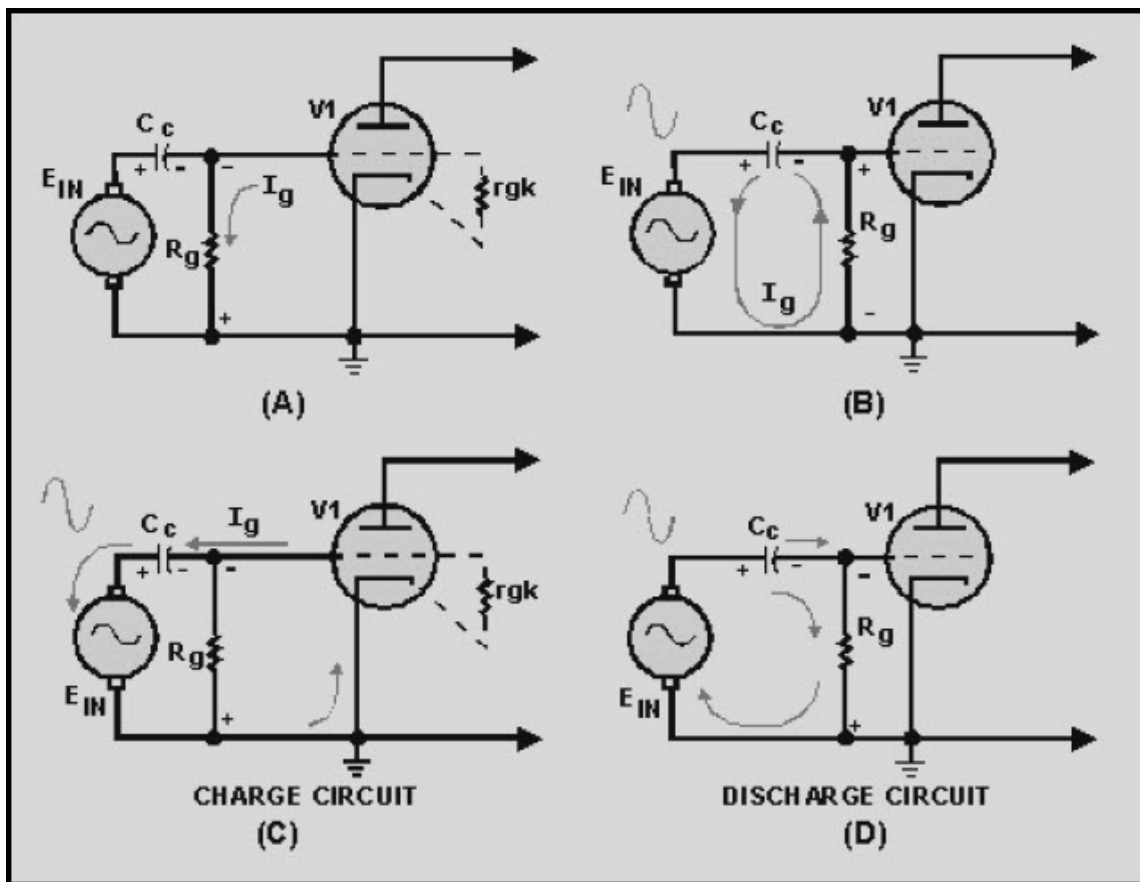

Figure 1-25 Shunt grid-leak biasing

NEETS MODULE 6-Electronic Emission, Tubes, and Power Supplies

UNCLASSIFIED

In view B of the figure, the first positive alternation of a series of ac alternations, E_{in} is applied to the circuit. The positive-going voltage causes the left-hand plate of C_c to go positive. The left-hand plate must lose electrons to go positive. These electrons leave the left-hand plate of C_c and travel to the input source where they will be coupled to ground. From ground, current flows through R_g causing a negative (bottom) to positive (top) voltage drop across R_g . In effect, the ac signal has been coupled across the capacitor. Because of this, capacitors are said to pass the ac signal while blocking dc. (In reality, the ac signal is coupled around the capacitor.) In view C of the figure, the positive-going voltage at the top of R_g will be coupled to the grid causing the grid to go positive. The positively charged grid will attract electrons from the electron stream in the tube. Grid current will flow from the grid to the right-hand plate of C_c . This will cause the right-hand plate to go negative. (Electrostatic repulsion from the right-hand plate of C_c will force electrons from the left-hand plate of C_c , causing it to go positive.) The electrons will flow through the signal source, to ground, from ground to the cathode, from the cathode to the grid, and finally to the right-hand plate of C_c . This is the biasing charge cycle. You may wonder why the charge current went through the tube rather than through R_g . When the grid goes positive in response to the positive-going input signal, electrostatic attraction between the grid and cathode increases. This, in turn, reduces the resistance (rgk) between the grid and cathode. Current always follows the path of least resistance. Thus, the capacitor charge path is through the tube and not through R_g .

When the first negative alternation is applied to the circuit (view D), the left-hand plate of C_c must go negative. To do this, electrons are drawn from the right-hand plate. The electrons travel from the right-hand plate of C_c , through R_g causing a voltage drop negative (top) to positive (bottom), from the bottom of R_g , through the source, to the left-hand plate of C_c . C_c will discharge for the duration of the negative alternation. **BUT C_c can only discharge through R_g , which is a high-resistance path, compared to the charge path.** Remember from your study of capacitors that RC time constants and the rate of discharge increase with the size of R . C_c can therefore charge through the low resistance of rgk to its maximum negative value during the positive half-cycle. Because C_c discharges through R_g (the high resistance path), it cannot completely discharge during the duration of the negative half-cycle. As a result, at the completion of the negative alternation, C_c still retains part of the negative charge it gained during the positive alternation. When the next positive alternation starts, the right-hand plate of C_c will be more negative than when the first positive alternation started.

During the next cycle, the same process will be repeated, with C_c charging on the positive alternation and discharging a lesser amount during the negative alternation. Therefore, at the end of the second cycle, C_c will have an even larger negative charge than it did after the first cycle. You might think that the charge on C_c will continue to increase until the tube is forced into cutoff. This is not the case. As the negative charge on the right-hand plate of C_c forces the grid more negative, electrostatic attraction between the grid and cathode decreases. This, in effect, increases the resistance (rgk) between the cathode and the grid, until rgk becomes, in effect, the same size as R_g . At this point, charge and discharge of C_c will equal one another and the grid will remain at some negative, steady

NEETS MODULE 6-Electronic Emission, Tubes, and Power Supplies UNCLASSIFIED

voltage. What has happened in this circuit is that C_c and R_g , through the use of unequal charge and discharge paths, have acted to change the ac input to a negative dc voltage. The extent of the bias on the grid will depend on three things: the amplitude of the input, the frequency of the input, and the size of R_g and C_c . This type of biasing has the advantage of being directly related to the amplitude of the input signal. If the amplitude increases, biasing increases in step with it. The main limiting factor is the amount of distortion that you may be willing to tolerate. Distortion occurs during the positive alternation when the grid draws current. Current drawn from the electron stream by the grid never reaches the plate; therefore the negative-going output is not a faithful reproduction of the input, while the positive-going output (during the negative input cycle) will be a faithful reproduction of the input. This is similar to the situation shown in the flat-topped portion of the output signal in figure 1-20.

The **SERIES GRID-LEAK BIAS** circuit shown in figure 1-26 operates similarly to the shunt grid-leak circuit. When the first positive alternation is applied to the left-hand plate of the grid capacitor, C_g , the left-hand plate must lose electrons to go positive with the input. Electrons will leave the left-hand plate and flow through R_g , causing a negative (left-hand side) to positive (right-hand side) voltage drop. From the right-hand side of R_g , the electrons will flow to the right-hand plate of C_g . The positive voltage developed at the right-hand side of R_g will be coupled to the grid. As the grid goes positive, it will draw current, causing C_g to start to charge through the low resistance path of the tube. During the negative alternation of the input, C_g will discharge through the high resistance path of R_g . Once again it will not be completely discharged at the end of the negative alternation, and the capacitor will continue on its way toward charge equilibrium.

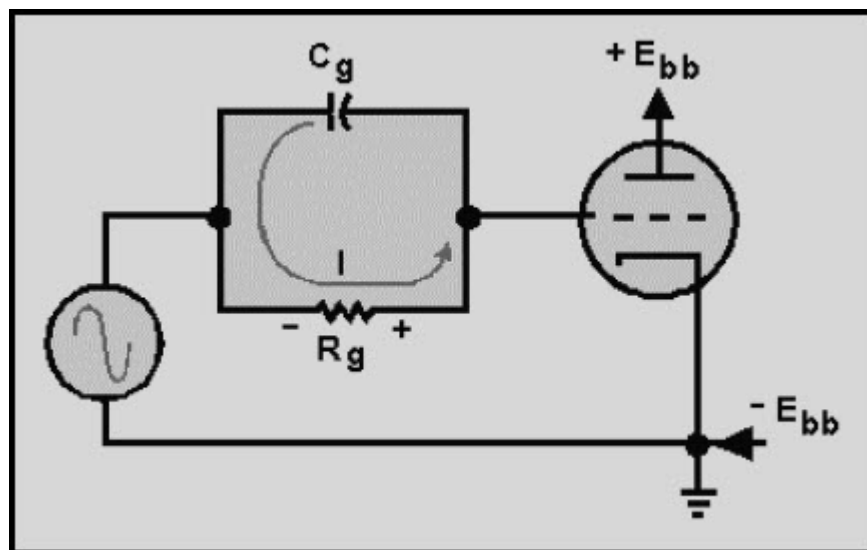

Figure 1-26 Series grid-leak biasing

NEETS MODULE 6-Electronic Emission, Tubes, and Power Supplies
UNCLASSIFIED

In summary, grid-leak bias causes the grid to draw current when the input signal goes positive. This grid current (which is a negative charge) is stored by the coupling capacitor (C_c) which will keep the grid at some negative potential. It is this potential that biases the tube.

Q21. What type of bias requires constant current flow through the cathode circuit of a triode?

Q22. When a circuit uses cathode biasing, the input signal can cause variations in the biasing level. How is this problem eliminated?

Q23. In a circuit using grid-leak biasing, the coupling capacitor (C_c) charges through a low resistance path. What resistance is used in this charge path?

Q24. Grid-leak biasing in effect rectifies the input ac signal. What feature of the circuit is used to accomplish this rectification?

NEETS MODULE 6-Electronic Emission, Tubes, and Power Supplies UNCLASSIFIED

1.5 OPERATING CLASSIFICATIONS OF TUBE AMPLIFIERS

While the discussion of amplifiers will be covered in detail in later *NEETS* modules, some discussion of the classes of operation of an amplifier is needed at this point. This is because their operation class is directly determined by the bias voltage of the tube.

The classification of amplifiers by operation is based on the percentage of the time that the tube conducts when an input signal is applied. Under this system amplifiers may be divided into four main classes: A, AB, B, and C.

1.5.1 Class A Operation

An amplifier biased into Class A operation, is one in which conduction through the tube occurs throughout the duration of the input signal. Such an amplifier is shown in figure 1-27, view A. This is the same type of circuit with which you are already familiar. Notice when you compare the input to the output that the tube is always conducting, and that the entire input signal is reproduced at the output.

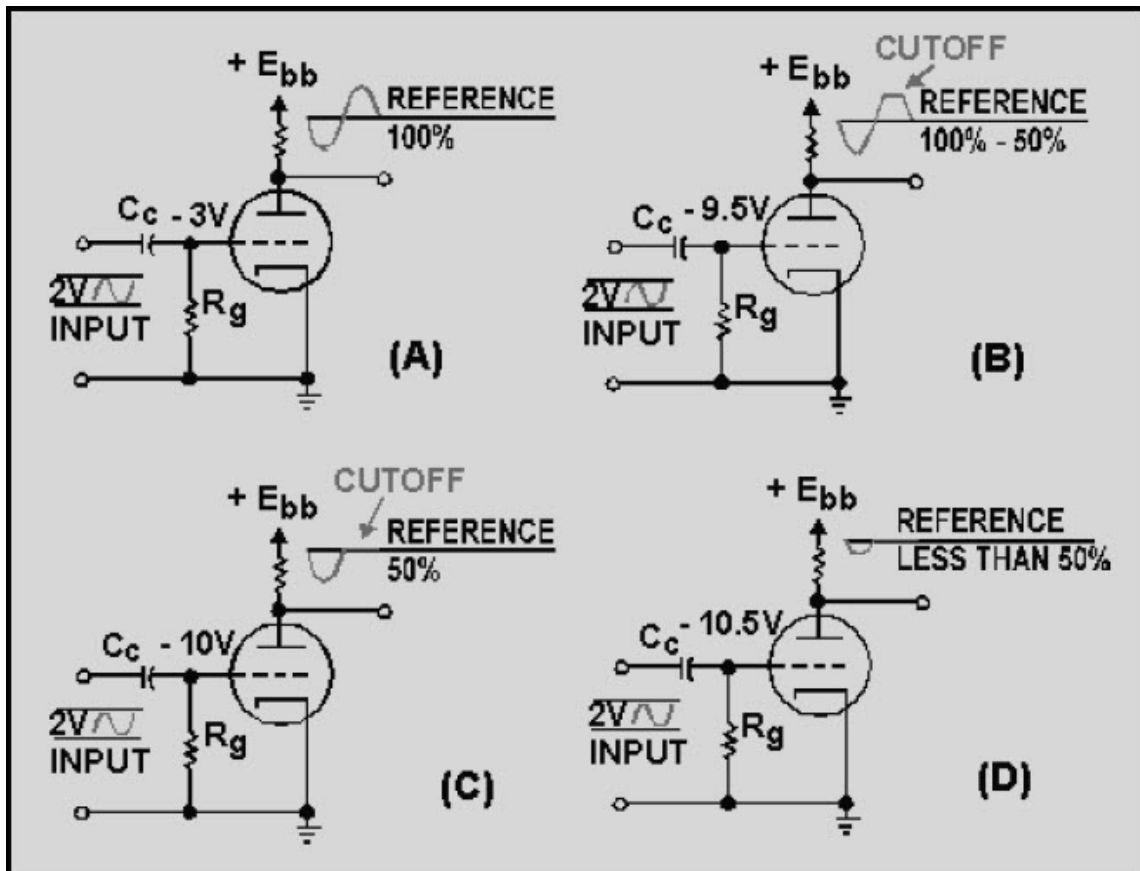

Figure 1-27 Classes of amplifier operation

NEETS MODULE 6-Electronic Emission, Tubes, and Power Supplies

UNCLASSIFIED

1.5.2 Class AB Operation

The Class AB amplifier is one in which the tube conducts for more than half, but less than the entire input cycle.

View B of figure 1-27 depicts an amplifier biased into **CLASS AB** operation. Notice that in this application, grid bias has been increased to -9 volts. We will assume that the tube reaches cutoff when the voltage on the grid is -10 volts. Under these conditions, when the input reaches -10 volts, the tube will cut off and stay cut off until the input goes above -10 volts. The tube conducts during the entire duration of the positive alternation and part of the negative alternation. If you remember back in the discussion of distortion, we pointed out that this represents distortion. In some amplifiers, faithful reproduction of the input is not an important requirement. Class AB amplifiers are used only where this distortion can be tolerated.

1.5.3 Class B Operation

A **CLASS B** biased amplifier is one in which the tube will conduct for only half of the input signal duration. This is done by simply biasing the amplifier at cutoff. View C of figure 1-27 depicts a class B biased amplifier.

As you can see, the tube conducts on the positive alternations. As soon as the input signal voltage reaches 0 volts, the tube cuts off. The tube will remain cut off until the input signal voltage climbs above zero volts on the next positive alternation. Because the tube conducts during the entire positive alternation, but not on the negative alternation, the tube conducts for only half the input cycle duration.

1.5.4 Class C

CLASS C amplifiers are biased below cutoff, so that the tube will conduct for less than half of the input signal cycle duration. View D of figure 1-27 depicts a Class C amplifier. Notice that the tube is biased one-half volt below cutoff. The tube will only conduct on that part of the positive alternation that is above +.5 volts. Therefore, the tube conducts for less than one-half cycle of the input. Again, this class can be applied only where severe distortion can be tolerated.

NEETS MODULE 6-Electronic Emission, Tubes, and Power Supplies

UNCLASSIFIED

1.5.5 Tube Constants

In the discussion of triodes, we only considered the effects of the external circuit on the passage of current through the tube. The behavior of the electron stream in a conducting tube is also influenced by the physical structure of the tube. The effects that the physical structure of a tube has on the tube's operation are collectively called **TUBE CONSTANTS**. Four of the most important of these tube constants are: **TRANSIENT TIME, INTERELECTRODE CAPACITANCE, TRANSCONDUCTANCE, and AMPLIFICATION FACTOR.**

1.5.5.1 Transit Time

Unlike electron flow in a conductor, electrons in a vacuum tube do not move at the speed of light. Their velocity is determined by the potential difference between the plate and the cathode. The amount of time the electrons take to travel from the cathode to the plate is called **TRANSIT TIME**. As a result of this time difference, the appearance of a signal at the end of a tube is not followed instantaneously by a change in current flow in the tube. Under normal conditions, the effect of this small time lag between the input signal and a change in tube current is unnoticed. However, at frequencies such as those used in radar equipment, this is not the case. Transit time at these frequencies has a very marked effect on tube operation. It is a major factor that limits the use of a given tube at higher frequencies.

Q25. Match each amplifier characteristic listed below with its class of amplification.

- a. Current flows through the tube for one-half cycle.*
- b. Current flows through the tube for less than one-half cycle.*
- c. Current flows through the tube for the entire cycle.*

NEETS MODULE 6-Electronic Emission, Tubes, and Power Supplies

UNCLASSIFIED

1.5.5.2 MU and Transconductance

In your study of triodes so far, you have seen that the output of a triode circuit is developed across the tube. The output is caused by the voltage dropped across R_L due to current flow from tube conduction. In all the demonstrations of gain, we assumed that R_L was held constant and current through the tube was varied. In this manner we achieved a voltage gain. If the resistance of R_L is changed by the designer, the gain of a triode circuit can be either increased or decreased. This is fairly easy to understand. Assume that a circuit is composed of a triode with a plate-load resistor of 100 kohms. If a +2 volt signal causes 2 additional milliamperes to conduct through the tube, the voltage drop across R_L (the output) will be:

$$E = I \times R$$

$$E = I_p \times R_L$$

$$E = (2 \times 10^{-3} \text{ amperes}) \times (100 \times 10^3 \text{ ohms})$$

$$E = 2 \times 100 \text{ volts}$$

$$E = 200 \text{ volts}$$

$$\text{Gain} = \frac{\text{output}}{\text{input}}$$

$$\text{Gain} = \frac{200 \text{ volts}}{2 \text{ volts}}$$

$$\text{Gain} = 100$$

Thus, the gain of the circuit is 100.

NEETS MODULE 6-Electronic Emission, Tubes, and Power Supplies UNCLASSIFIED

If the plate-load resistor is reduced to 50 kohms and the input is kept at +2 volts, the gain will be reduced to:

$$E = (2 \times 10^{-3}) \times (50 \times 10^3 \text{ ohms})$$

$$E = 2 \times 50 \text{ volts}$$

$$E = 100 \text{ volts}$$

$$\text{Gain} = \frac{100 \text{ volts}}{2 \text{ volts}}$$

$$\text{Gain} = 50$$

As you can see, voltage gain depends on both the tube characteristics and the external circuit design.

The voltage gain is a measure of circuit efficiency, not tube efficiency.

The actual characteristics of a tube are measured by two factors: mu (μ) or **AMPLIFICATION FACTOR**; and **TRANSCONDUCTANCE** or g_m . The amplification factor (represented as μ) of a tube is equal to the ratio of a change in plate voltage to the change in grid voltage required to cause the same change in plate current. This is expressed mathematically as

$$\mu = \frac{\Delta E_p}{\Delta E_g}$$

**NEETS MODULE 6-Electronic Emission, Tubes, and Power Supplies
UNCLASSIFIED**

While this may sound complicated, it really isn't. Look at figure 1-28. Here you see in view A a triode with a +1 volt input signal. At this grid voltage, current through the tube is at 1 milliampere. If the input voltage is raised to +3 volts, current through the tube increases to 2 milliamperes. The change in E_g (ΔE_g) is then 2 volts. This is shown in view B. Suppose that the grid voltage is returned to +1 volt, and the plate voltage is increased until the ammeter in view C reads 2 milliamperes of plate current. At this point plate voltage is measured. Plate voltage had to be increased by 100 volts (350-250) to get the same change in plate current (1 mA). The change in plate voltages (ΔE_p) is then 100 volts. The amplification factor (μ) of just the tube is then equal to

$$\mu = \frac{\Delta E_p}{\Delta E_g}$$

$$\mu = \frac{100 \text{ volts}}{2 \text{ volts}}$$

$$\mu = 50$$

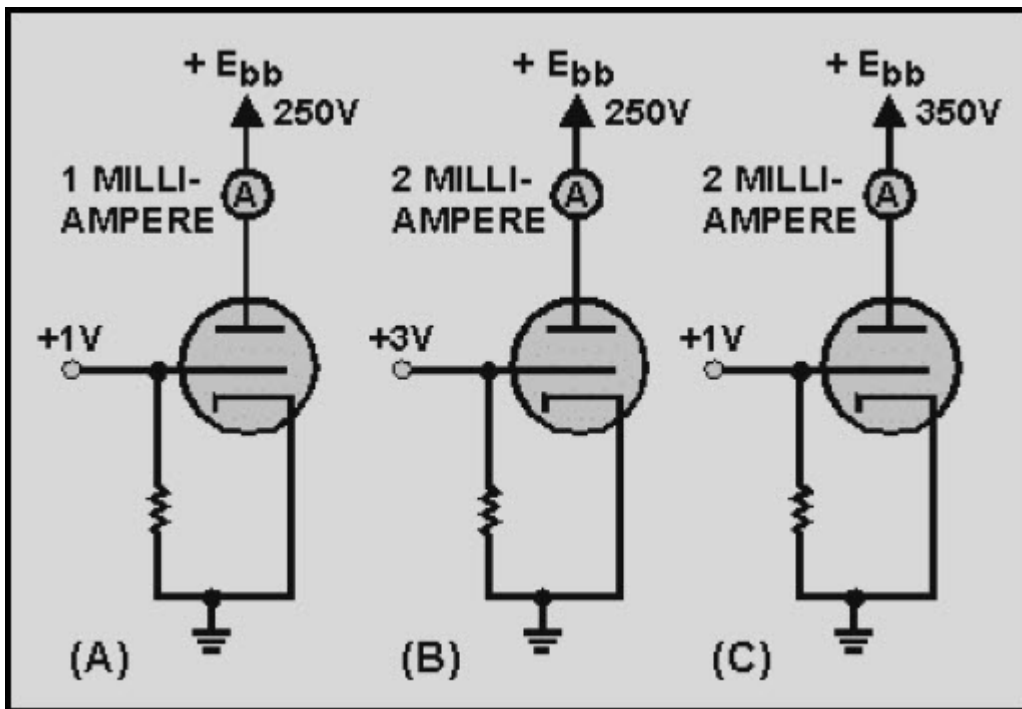

Figure 1-28 Obtaining gain and transconductance

NEETS MODULE 6-Electronic Emission, Tubes, and Power Supplies UNCLASSIFIED

As you can see, mu is a measure of the ability of a tube to amplify. By comparing the mu of two different types of tubes, you can get an idea of their efficiency. For example, assume you have two different tubes, one with a mu of 50, and the other with a mu of 100. If you place each tube in a circuit whose input varies by 2 volts, you can expect the following changes in plate voltage.

Tube 1:

$$\mu = \frac{\Delta E_p}{\Delta E_g}$$

$$\Delta E_p = \mu \times \Delta E_g$$

$$\Delta E_p = 50 \times 2 \text{ volts}$$

$$\Delta E_p = 100 \text{ volts}$$

Tube 2:

$$\mu = \mu \times \frac{\Delta E_p}{\Delta E_g}$$

$$\Delta E_p = \mu \times \Delta E_g$$

$$\Delta E_p = 100 \times 2 \text{ volts}$$

$$\Delta E_p = 200 \text{ volts}$$

Thus, you can expect twice the change in plate voltage from tube 2 as from tube 1 for the same input voltage. Therefore, tube 2 will have twice the gain of tube 1.

NEETS MODULE 6-Electronic Emission, Tubes, and Power Supplies

UNCLASSIFIED

1.5.5.2.1 Transconductance

Transconductance is a measure of the change in plate current to a change in grid voltage, with plate voltage held constant. The unit for conductance is the mho (siemens), pronounced "moe." Transconductance is normally expressed in either micromhos or millimhos. Mathematically, transconductance is expressed by the formula:

$$gm = \frac{\Delta I_p}{\Delta E_g}$$

Examine figure 1-28, views A and B, again. In view A, the input voltage is +1 volt. At +1 volt E_g , the plate current is equal to 1 milliamperere, with a plate voltage of 250 volts. In view B, the input voltage (E_g) is raised to +3 volts. ΔE_g , as before, is equal to 2 volts. This increase in grid voltage causes plate current to increase to 2 milliamperes. The change in plate current (ΔI_p) is then equal to 1 milliamperere. Thus, transconductance (g_m) is equal to:

$$gm = \frac{\Delta I_p}{\Delta E_g}$$

$$gm = \frac{1 \text{ milliamperere}}{2 \text{ volts}}$$

$$gm = .5 \text{ millimho or } 500\mu\text{mhos}$$

NEETS MODULE 6-Electronic Emission, Tubes, and Power Supplies UNCLASSIFIED

Remember that the voltage gain of a circuit is measured by the ratio of the change in plate voltage to the change in grid voltage. Because plate voltage is developed across a resistor, the more current varies with a given input signal, the greater will be the output ($E = I \times R$). If you have two tubes, one with a gm of 500 mhos and the other with a gm of 500 μ mhos, you can estimate the relative gain of these two tubes. Assume that the circuit in which you wish to use one of these tubes has a load resistor of 100 kohms and that ΔE_g will be 2 volts. The voltage gain of these two circuits will be:

Tube 1:

$$gm = \frac{\Delta I_p}{\Delta E_g}$$

$$\Delta I_p = \Delta E_g \times gm$$

$$\Delta I_p = 2 \times .5 \text{ millmho}$$

$$\Delta I_p = 1 \text{ milliampere}$$

$$\Delta E_p = \Delta I_p \times R_L$$

$$\Delta E_p = (1 \times 10^{-3} \text{ ampere}) \times (100 \times 10^3 \text{ ohms})$$

$$\Delta E_p = 100 \text{ volts}$$

$$\text{Gain} = \frac{\text{output}}{\text{input}}$$

$$\text{Gain} = \frac{100 \text{ volts}}{2 \text{ volts}} = 50$$

NEETS MODULE 6-Electronic Emission, Tubes, and Power Supplies
UNCLASSIFIED

Tube 2:

$$g_m = \frac{\Delta I_p}{\Delta E_g}$$

$$\Delta I_p = \Delta E_g \times g_m$$

$$\Delta I_p = 2 \text{ volts} \times 5 \text{ millmho}$$

$$\Delta I_p = 10 \text{ milliamperes}$$

$$\Delta E_p = \Delta I_p \times R_L$$

$$\Delta E_p = (10 \times 10^{-3} \text{ ampere}) \times (100 \times 10^3 \text{ ohms})$$

$$\Delta E_p = 1000 \text{ volts}$$

$$\text{Gain} = \frac{\text{output}}{\text{input}}$$

$$\text{Gain} = \frac{1000 \text{ volts}}{2 \text{ volts}} = 500$$

As you can see, tube 2 is 10 times the amplifier that tube 1 is.

Q26. The plate voltage of a tube will vary 126 volts when a 3-volt ac signal is applied to the control grid. What is the gain of this tube?

Q27. If the mu of a tube is 85 and the signal at the control grid is 4 volts ac, the plate voltage will vary by what amount?

Q28. Transconductance is a measure of the relationship between what two factors?

Q29. A tube has a transconductance of 800 mhos and a load resistor of 50 kohms. When control grid voltage varies by 6 volts, the plate voltage will vary by what amount?

NEETS MODULE 6-Electronic Emission, Tubes, and Power Supplies UNCLASSIFIED

1.5.5.3 Interelectrode Capacitance

As you know, capacitance exists when two pieces of metal are separated by a dielectric.

You should also remember from your studies that a vacuum has a dielectric constant of 1. As the elements of the triode are made of metal and are separated by a dielectric, capacitance exists between them. This capacitance is called *interelectrode capacitance*, and is schematically represented in figure 1-29.

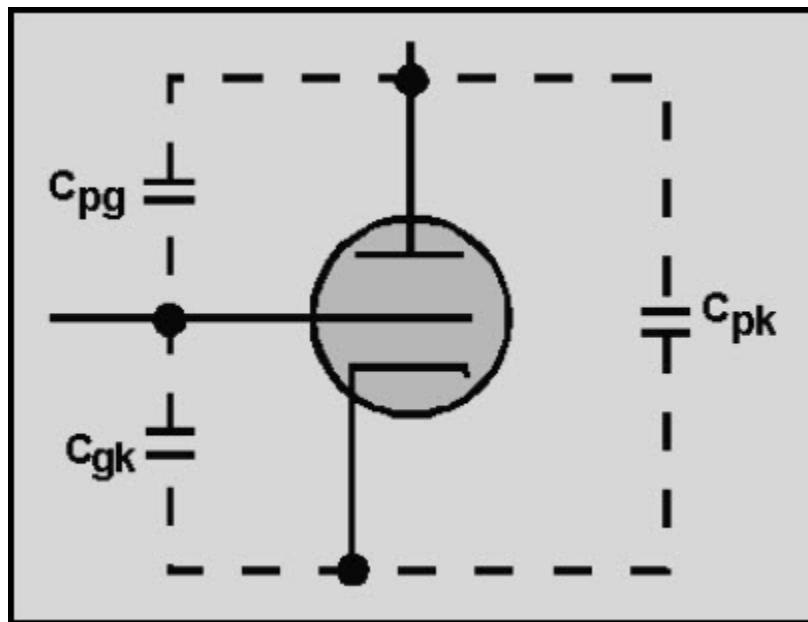

Figure 1-29 Schematic representation of interelectrode capacitance

Notice that there are three interelectrode capacitances involved in a triode. The capacitance between the plate and grid, designated C_{pg} , is the largest, because of the relatively large area of the plate, and therefore has the greatest effect on triode operation. The grid-to-cathode capacitance is designated C_{kg} .

The total capacitance across the tube is designated C_{pk} .

NEETS MODULE 6-Electronic Emission, Tubes, and Power Supplies UNCLASSIFIED

As we said earlier, C_{pg} has the greatest effect on the tube operation. This is because this capacitance will couple part of the ac signal from the plate back to the grid of the tube. The process of coupling the output of a circuit back to the input is called **FEEDBACK**. This feedback affects the gain of the stage. It may be desirable in some applications. In others, the effects must be neutralized. The effects of C_{pk} are greater at higher frequencies where X_c is lower.

1.5.6 Development of the Tetrode

Interelectrode capacitance cannot be eliminated from vacuum tubes, but it can be reduced. The easiest method found to reduce interelectrode capacitance is to split the capacitance between the grid and plate (C_{pg}) into two capacitors connected in series. This is done by placing an extra grid, called the **SCREEN GRID**, between the control grid and the plate. This is shown in figure 1-30.

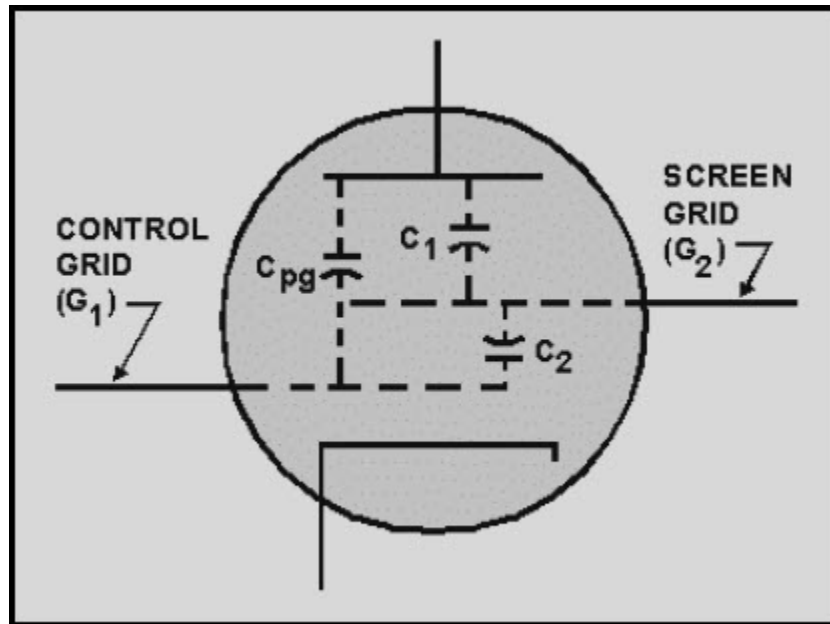

Figure 1-30 Effect of the screen-grid on Interelectrode capacitance

NEETS MODULE 6-Electronic Emission, Tubes, and Power Supplies UNCLASSIFIED

Remember from your study of capacitance that connecting capacitors in series reduces the total capacitance to a value smaller than either of the capacitors. This is mathematically summed up as follows:

$$C_T = \frac{C_1 \times C_2}{C_1 + C_2}$$

The addition of the screen grid has the effect of splitting C_{pg} into two capacitances (C_1 and C_2) connected in series. Therefore, the total interelectrode capacitance between the control grid and the plate is greatly reduced.

1.5.7 Operation of the Basic Tetrode Circuit

Figure 1-31 depicts a basic tetrode circuit. While the circuit may look complicated, it isn't. You are already familiar with most of the circuit. Only three components have been added: the screen grid, the screen grid dropping resistor, and the screen grid bypass capacitor (C_{sg}).

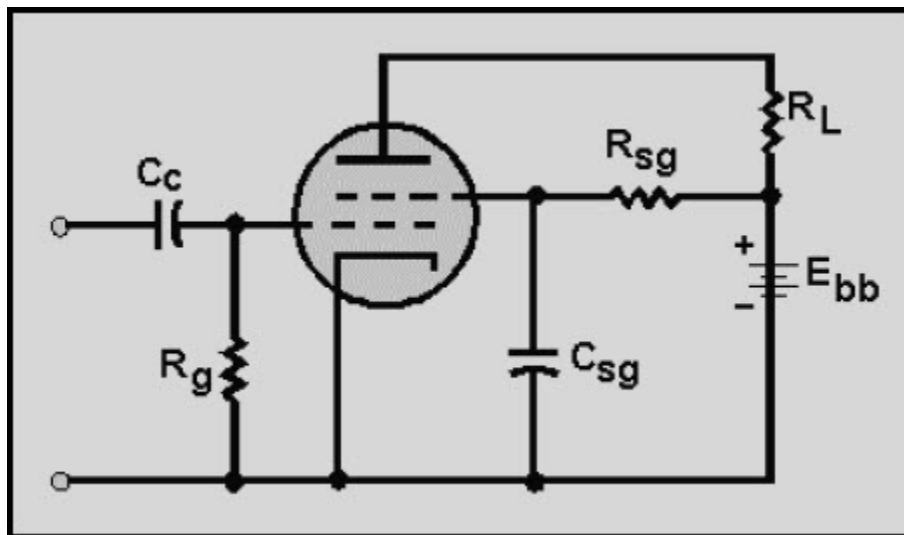

Figure 1-31 Basic tetrode circuit

NEETS MODULE 6-Electronic Emission, Tubes, and Power Supplies

UNCLASSIFIED

The problem now is: at what voltage and polarity should the screen grid be operated? If the screen grid were operated at a potential that would make it negative in relation to the control grid, it would act as a negative screen between the plate and control grid. As a result, gain would be reduced. If the screen grid were operated at plate potential, it would draw current from the electron stream when the tube conducts. Because of this, the value of R_{sg} is normally selected to cause the screen grid to be positive in relation to the control grid, but not as positive as the plate.

Despite this precaution, the screen grid still draws some current from the electron stream. Any signal applied to the control grid will appear at the screen grid inverted by 180° from the input signal. This is undesirable, as it reduces the gain of the tube. Consider the effect if the control grid goes positive. Conduction through the tube increases and since the screen grid is in the electron stream, it will draw some current. This causes the screen grid to go toward negative potential (less positive). The effect then, is to place a negative-going electrode between the plate and positive-going control grid. The plate becomes partially screened by the negative-going screen grid, and again, gain will decrease. Because the signal at the screen grid is always 180° out of phase with the control grid, its effect will always be to oppose the effect of the control grid.

To overcome this, a bypass capacitor (C_{sg}) is connected between the screen grid and ground. The addition of this capacitor will shunt, or pass, the ac variations on the screen grid to ground while maintaining a steady dc potential on the screen grid. In other words, C_{sg} moves all of the undesired effects mentioned in the previous paragraph.

One very useful characteristic of the tetrode tube is the relationship between the plate and screen grid. The screen grid will lessen the effect that a decreasing plate potential (negative-going signal) has on conduction through the tube. In a triode, when the grid goes positive, the plate goes negative. This decreases electrostatic attraction across the tube and tends to decrease the gain somewhat.

In a tetrode, the screen grid has the ability to isolate the effect that ac variations on the plate have on the electron stream.

The positively charged screen grid will accelerate electrons across the tube even though the plate is negative going. As long as the plate remains positive in relation to the cathode, it will draw off these accelerated electrons. As a result, conduction through the tube when the plate is going negative will not be decreased. This is another big advantage of screen-grid tubes.

NEETS MODULE 6-Electronic Emission, Tubes, and Power Supplies

UNCLASSIFIED

1.5.8 Tetrode Characteristics

Because the screen grid is in the electron stream, it will always draw some current. The current drawn by the screen grid will be lost to the plate. This means that the transconductance of a tetrode, which is based on the amount of plate current versus control-grid voltage, will be lower in tetrodes than in triodes. The formula for transconductance of a triode,

$$g_m = \frac{\Delta I_p}{\Delta E_g}$$

must be adjusted for screen-grid current, and becomes

$$g_m = \frac{\Delta I_p - \Delta I_{sg}}{\Delta E_g}$$

As you can see, the transconductance for a tetrode can never be as high as that of a triode of similar construction.

While lowered transconductance in a tetrode is an undesirable characteristic, it is not the reason that tetrodes have found little acceptance in electronics. The factor that severely limits the operation of tetrodes is **SECONDARY EMISSION**.

Because the screen grid is positively charged, electrons traveling from the cathode to the plate are accelerated. Electrons are accelerated to such an extent that they dislodge electrons from the plate when they strike it. This is similar to the manner in which a high-velocity rifle bullet fired into a pile of sawdust throws sawdust about. Some of these electrons are fired back into the tube, where they tend to accumulate between the screen grid and the plate. This effect is most pronounced when the signal at the control grid is going positive and conduction through the tube is increasing. The plate in this situation is going negative in answer to the control-grid signal. This causes the electrons accumulating between the plate and screen grid to be attracted to the screen grid. The current that is drawn by the screen grid is lost to the plate and gain is decreased. Gain is also decreased in another way. The negative charge accumulated by secondary emission causes some of the electrons (from the cathode) to be repelled from the plate, which further reduces gain.

NEETS MODULE 6-Electronic Emission, Tubes, and Power Supplies
UNCLASSIFIED

Another undesirable characteristic of tetrodes associated with secondary emission is that the outputs are **NOISY**. What this means is that small sporadic signals appear on the main output signal, as shown in figure 1-32. When electrons are knocked from the plate, they represent losses of plate current and corresponding positive pulses on the output. Electrons falling back to the plate represent increases in plate current and cause negative-going pulses to appear in the output.

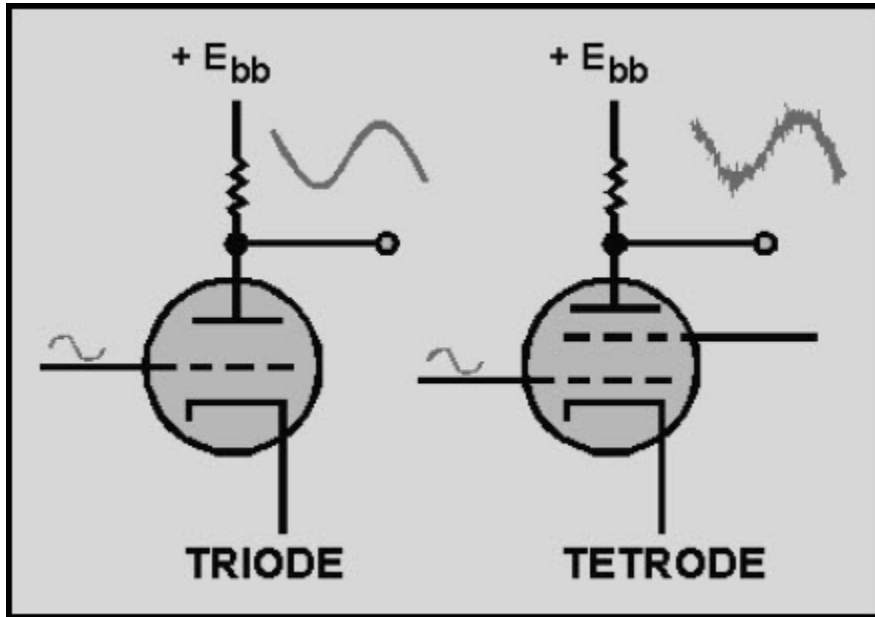

Figure 1-32 Noise in a tetrode circuit

For these reasons tetrodes are only used in very specialized applications of electronics.

Q30. How does the addition of a screen grid in a tetrode reduce interelectrode capacitance?

Q31. What undesirable effect does the screen grid in a tetrode create?

NEETS MODULE 6-Electronic Emission, Tubes, and Power Supplies UNCLASSIFIED

1.6 THE PENTODE

The problem of secondary emission associated with the screen grid of a tetrode has been reduced by - you guessed it, the addition of another grid.

This third grid, called a **SUPPRESSOR GRID**, is placed between the screen grid and the plate. The suppressor grid is normally connected either internally or externally to the cathode and bears the same charge as the cathode. This is shown in figure 1-33. Because of its negative potential (relative to individual electrons), any electrons that are emitted by the plate, through secondary emission, are repelled back toward the plate.

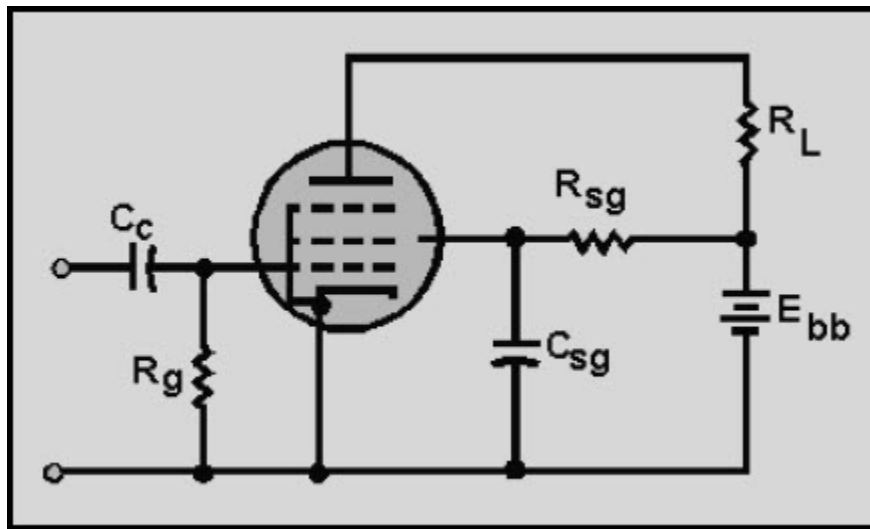

Figure 1-33 Basic pentode circuit

You might think that a grid with a negative potential placed close to the plate would interfere with the electron stream. However, this is not the case. Because the suppressor grid is negatively charged, it will not draw grid current. Additionally, the wide spacing within the mesh of the suppressor and its location between two positive elements of the tube ensures that the suppressor grid's effect on the electron stream will be minimum. Only the electrons emitted by secondary emission from the plate are affected by the suppressor grid.

Because pentodes do not suffer from secondary emission, they have replaced the tetrode in most applications.

NEETS MODULE 6-Electronic Emission, Tubes, and Power Supplies
UNCLASSIFIED

Q32. The suppressor grid is added to a tetrode to reduce what undesirable characteristic of tetrode operation?

Q33. On the diagram below, name the elements of the vacuum tube and their potentials relative to dc ground.

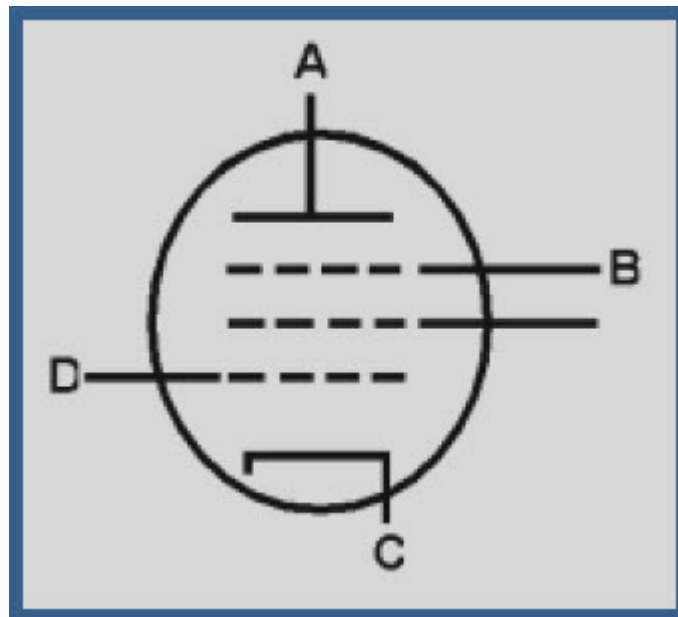

NEETS MODULE 6-Electronic Emission, Tubes, and Power Supplies

UNCLASSIFIED

1.7 SUMMARY

This chapter has introduced you to the four basic types of vacuum tubes. The following is a summary of the main points of the chapter.

THERMIONIC EMISSION is caused when metallic substances are heated to high temperatures. Electrons liberated by thermionic emission provide the conduction currents of vacuum tubes.

A **DIODE VACUUM TUBE** is composed of two elements: the cathode and the plate.

The **CATHODE** is the electron-emitting element of a tube. Cathodes are usually composed of special materials that are heated either directly or indirectly.

DIODE OPERATION depends upon current flow through the tube. Because the cathode is the only electron-emitting element in the tube, current can only flow in one direction, from the cathode to the plate. For current to flow, the plate must be positive relative to the cathode. When the plate is negative relative to the cathode, current cannot flow within the tube.

The **CHARACTERISTIC CURVE** for an electron tube is a graphic plot of plate current (I_p) versus plate voltage (E_p). From this, dc plate resistance can be computed by the formula:

$$R_p = \frac{E_p}{I_p}$$

FACTORS THAT LIMIT VACUUM TUBE OPERATION are plate dissipation, maximum average current, maximum peak-plate current, and peak-inverse voltage.

DIODE RECTIFIERS take advantage of the fact that diodes will conduct in only one direction. When ac voltages are applied to diodes, conduction occurs only on the alternation that makes the plate positive relative to the cathode. Because of this, the output current consists of one polarity. Because it flows in pulses rather than continuously, it is called pulsating dc.

DIODE CONSTRUCTION is the basic construction plan of most vacuum tubes. The tube is constructed of the following parts: filament and/or cathodes, plates, envelope, and base.

NEETS MODULE 6-Electronic Emission, Tubes, and Power Supplies

UNCLASSIFIED

A **TRIODE** is basically a diode with a control grid mounted between the plate and the cathode. The control grid gives the triode the ability to amplify signals.

The **OPERATION OF A TRIODE** depends on the ability of the control grid to either increase or decrease conduction through the tube in response to an ac input signal. The output voltage is developed across the tube between the cathode and plate because of the voltage drop across the plate-load resistor changing as the plate current responds to the input signal.

TUBE BIASING is the process of placing a dc voltage, usually negative, on the grid. Bias has several functions in circuit design. Biasing may be divided into two types: fixed and self. Tubes using fixed bias have a dc voltage applied to their control grids from an external source such as a battery. Self-biasing voltages, on the other hand, are derived from current conducting through the tube. The most common types of self-biasing are cathode biasing and grid-leak biasing.

The **CLASS OF OPERATION OF AN AMPLIFIER** is determined by the bias applied to a triode. An amplifier operating as class A conducts continually through the duration of the input cycle. Class AB operation occurs when the amplifier conducts for more than half but less than the entire duration of the input cycle. A class B amplifier conducts for only 50% of the input cycle. The class C amplifier conducts for less than half of the input cycle.

TRANSIT TIME is the time required for electrons emitted by the cathode to reach the plate. Because transit time in a vacuum tube is considerably less than the speed of light, vacuum tube operation is affected at high frequencies.

INTERELECTRODE CAPACITANCE is created by the naturally occurring capacitance between elements in a vacuum tube. One effect of interelectrode capacitance is to feed back a portion of the output of a triode to the input. This effect is a prime-limiting factor in applying triodes. It is a major reason why triodes are seldom used - especially at the higher frequencies.

MU AND TRANSCONDUCTANCE are measures of tube efficiency. Mu (μ), or amplification factor, is a measure of the amount that plate voltage varies in relation to variation of the input voltage. Mathematically, mu (μ) is expressed as

$$\mu = \frac{\Delta E_p}{\Delta E_g}$$

NEETS MODULE 6-Electronic Emission, Tubes, and Power Supplies

UNCLASSIFIED

TRANSCONDUCTANCE, on the other hand, is a measure of the amount of variation of plate current caused by a variation of the input signal. Mathematically, it is expressed as:

$$gm = \frac{\Delta I_p}{E_g}$$

TETRODES were developed to compensate for the effects of interelectrode capacitance. Placing a positively charged screen grid between the control grid and plate has the effect of adding a capacitor in series with the capacitance that exists between the control grid and plate. This reduces total capacitance below the value of either capacitor as shown by applying the formula:

$$C_T = \frac{C_1 \times C_2}{C_1 + C_2}$$

SECONDARY EMISSION of electrons from the plate is caused by the acceleration of electrons by the screen grid. This causes the performance of a tetrode to be degraded. In addition to reduced amplitude, the output signals become noisy.

PENTODES do not suffer from the effects of secondary emission. This is because a negatively charged suppression grid placed between the screen grid and plate forces any electrons emitted back to the plate.

NEETS MODULE 6-Electronic Emission, Tubes, and Power Supplies
UNCLASSIFIED

ANSWERS TO QUESTIONS Q1. THROUGH Q33.

A1. By heating it.

A2. Because the negatively charged electrons are attracted to the positively charged plate.

A3. Filament and plate.

A4. Negative.

A5. Positive.

A6. Pulsating dc.

A7. Thoriated-tungsten and oxide-coated metals.

A8. They reach operating temperatures quickly.

A9. It serves as a mounting for the tube elements and as the terminal connection to the circuit.

A10. The linear portion.

A11. Plate resistant R_p .

A12. Peak Inverse Voltage (PIV).

A13. The triode contains a third element called the control grid.

A14. Because it is closer to the cathode.

A15. A plate load resistor R_L .

A16. To prevent them from drawing grid current.

A17. The input signal

A18. +275 volts.

A19.

a. 100 volts.

b. 180° out of phase.

NEETS MODULE 6-Electronic Emission, Tubes, and Power Supplies
UNCLASSIFIED

A20.

- a. Cutoff.
- b. Saturation.

A21. Cathode biasing.

A22. Through the use of a bypass capacitor

A23. r_{kg} , the cathode to grid resistance.

A24. Unequal charge and discharge paths of the coupling capacitor C_c .

A25.

- a. Class B.
- b. Class C
- c. Class A.

A26. 42.

A27. 340 volts.

A28. The changes in plate current and grid voltage.

A29. 240 volts.

A30. The interelectrode capacitance (c_{pg}) is divided between two series capacitances; thus, c_{pg} is greatly reduced.

A31. Secondary emission, and noise.

A32. Secondary emission.

A33.

- a. Plate, positive.
- b. Suppressor grid, negative.
- c. Cathode, can be negative, positive, or at dc ground potential, depending on biasing type.
- d. Control grid, negative.

NEETS MODULE 6-Electronic Emission, Tubes, and Power Supplies

UNCLASSIFIED

2 SPECIAL-PURPOSE TUBES

LEARNING OBJECTIVES

Upon completion of this chapter, you will be able to:

1. Determine the number and type of individual tubes contained within the signal envelope of a multi-unit tube.
2. Explain the function and operating principle of the beam power tube and the pentode tube.
3. State the difference between the capabilities of conventional tubes and variable-mu tubes.
4. Describe the construction of uhf tubes, and explain the effects that ultra-high frequencies have on conventional-tube operation.
5. Explain the operation of gas-filled diodes, thyratrons, and cold-cathode tubes.
6. Explain the operating principles behind cathode-ray tubes, and the manner in which these tubes present visual display of electronic signals.

2.1 INTRODUCTION

Because of their great versatility, the four basic tube types (diode, triode, tetrode, and pentode) covered in chapter 1 have been used in the majority of electronic circuits. However, these types of tubes do have limits, size, frequency, and power handling capabilities.

Special-purpose tubes are designed to operate or perform functions beyond the capabilities of the basic tube types discussed in chapter 1. The special-purpose tubes covered in this chapter will include multi-unit, multi-electrode, beam power, power pentode, variable-mu, uhf, cold cathode, thyratrons, and cathode-ray tubes.

NEETS MODULE 6-Electronic Emission, Tubes, and Power Supplies UNCLASSIFIED

2.2 MULTI-UNIT AND MULTI-ELECTRODE TUBES

One of the problems associated with electron tubes is that they are bulky. The size of an electron tube circuit can be decreased by enclosing more than one tube within a single envelope, as mentioned in chapter 1. There is a large variety of tubes that can be combined into this grouping of "specialty tubes" called **MULTI-UNIT** tubes. Figure 2-1 illustrates the schematic symbols of a few of the possible combinations found in multi-unit tubes.

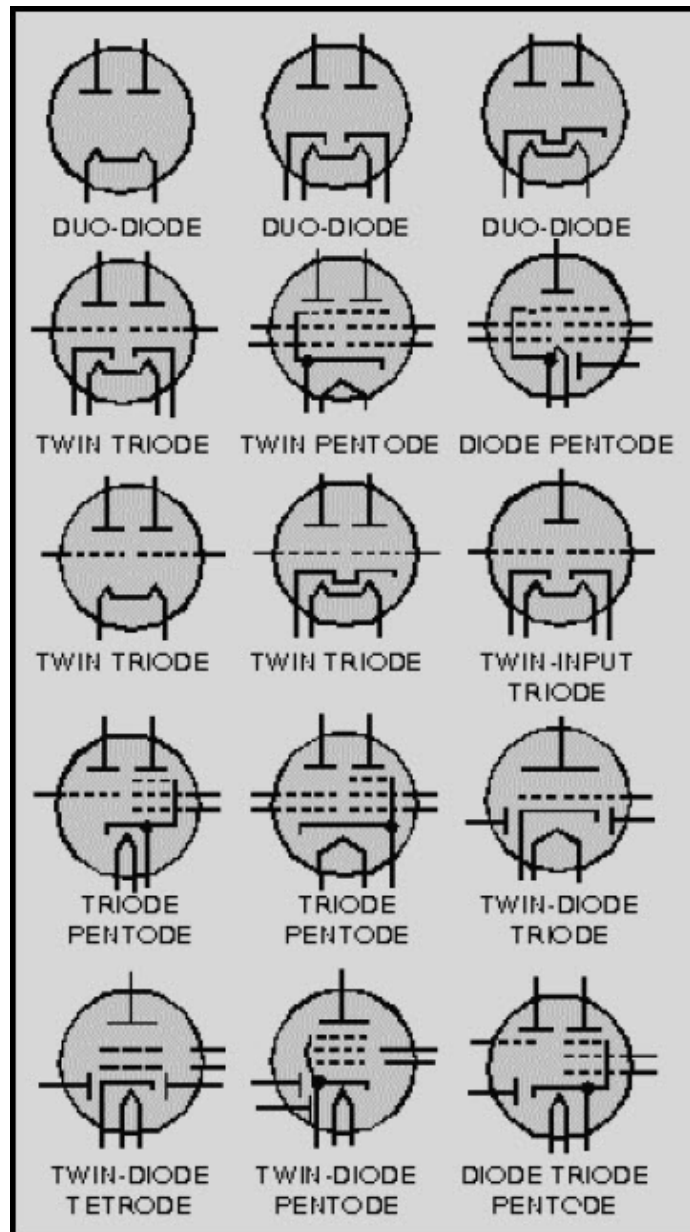

Figure 2-1 Typical multi-unit tube symbols

NEETS MODULE 6-Electronic Emission, Tubes, and Power Supplies UNCLASSIFIED

An important point to remember when dealing with multi-unit tubes is that each unit is capable of operating as a separate tube. But, how it operates, either as a single tube or as a multi-unit tube, is determined by the external circuit wiring. When you analyze the schematic of a circuit, simply treat each portion of a multi-unit tube as a single tube, as shown in figure 2-2.

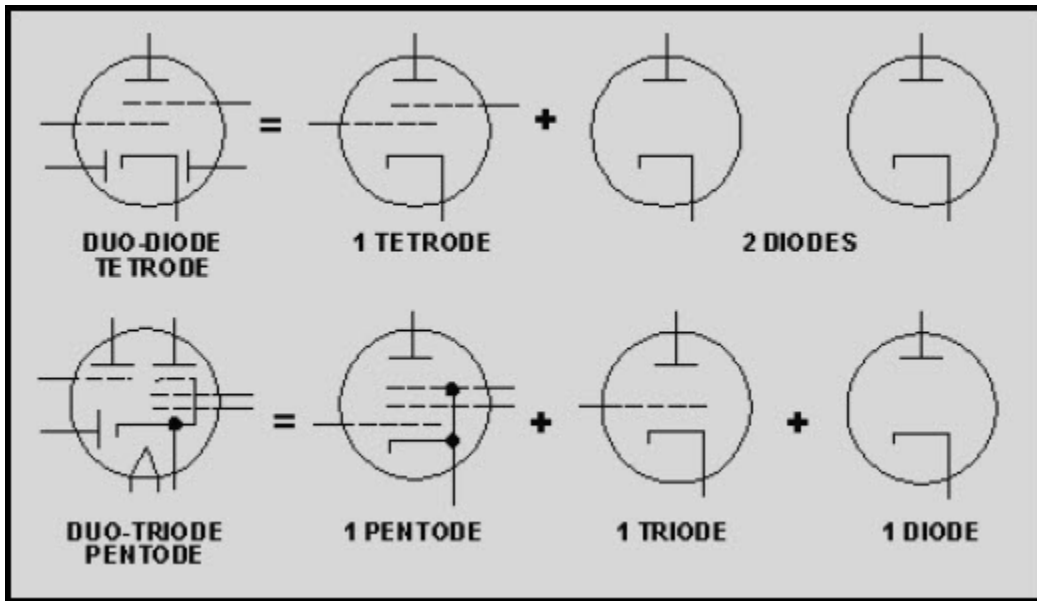

Figure 2-2 Multi-unit tube Identification

Another type of special-purpose tube is the **MULTI-ELECTRODE** tube. In some applications, tubes require more than the three grids found in conventional tubes. In some cases, up to seven grids may be used. These types of tubes are called multi-electrode tubes and are normally classified according to the number of grids they contain. An example of this is illustrated in figure 2-3. Here, you see a tube with five grids; hence, its name is "pentagrid." The application of these tube types is beyond the scope of this module, but because multi-electrode tubes have been commonly used you should be aware of their existence.

NEETS MODULE 6-Electronic Emission, Tubes, and Power Supplies
UNCLASSIFIED

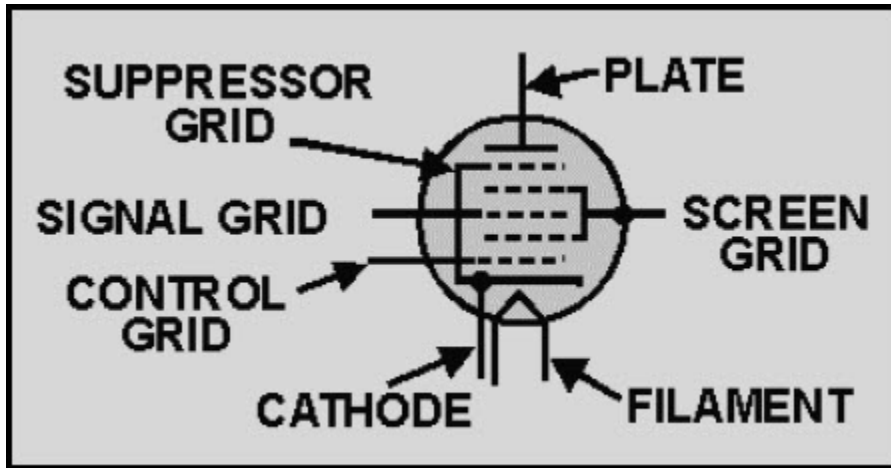

Figure 2-3 Pentagrid multi-electrode tube

2.3 BEAM POWER AND POWER PENTODE TUBES

The tube types you studied in the first chapter have one serious drawback; namely, they are not suitable as power amplifiers. Because of high-plate resistance and internal construction, tubes such as the triode, tetrode, and pentode are used only as voltage amplifiers. When power amplification is required (high-current requirements), special-purpose tubes called **POWER PENTODES** and **BEAM POWER** tubes are used.

Figure 2-4 shows the arrangement of grids in a conventional pentode. The small circles depict cross sections of the grids. Notice that each grid is offset, or staggered, from the grid directly behind it. This arrangement of grids permits each grid to be exposed to the electron stream flowing from cathode to plate.

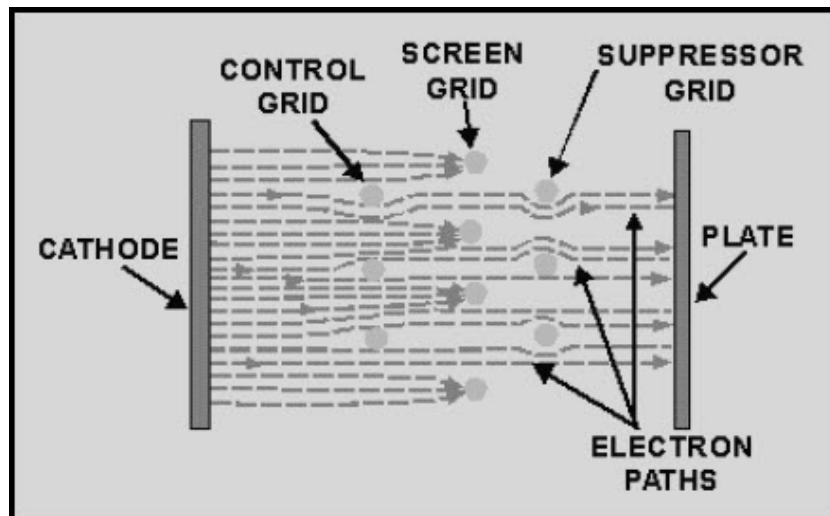

Figure 2-4 Electron flow in a conventional pentode

NEETS MODULE 6-Electronic Emission, Tubes, and Power Supplies UNCLASSIFIED

In this way, each grid will have maximum effect on the electron stream. There are two undesirable effects associated with the staggered grid arrangement that make it unsuitable for use in power amplifiers.

First, no direct path exists between the cathode and the plate. Electrons leaving the cathode must run an obstacle course around the grid wires to reach the plate. Some of these electrons are deflected by the grid and scattered and, thus, never reach the plate. Second, some electrons strike the grid wires and are removed from the electron stream as grid current. Because of these two undesirable effects, the amount of plate current that can flow through the tube is greatly reduced. Because of this loss of electrons from the stream, conventional tetrodes and pentodes are not suitable for power amplifiers. Therefore, a special class of tubes has been developed to overcome this problem - the **BEAM POWER TUBES** and **POWER PENTODE TUBES**.

Figure 2-5 shows the cross section of the power pentode. Notice that there is no staggered grid arrangement. Instead, each grid wire is directly in line with the grid in front of and behind it. The screen and suppressor grids are shielded from the electron stream by the control grid. Because the screen grid is "shielded" by the control grid, it can draw little grid current from the electron stream.

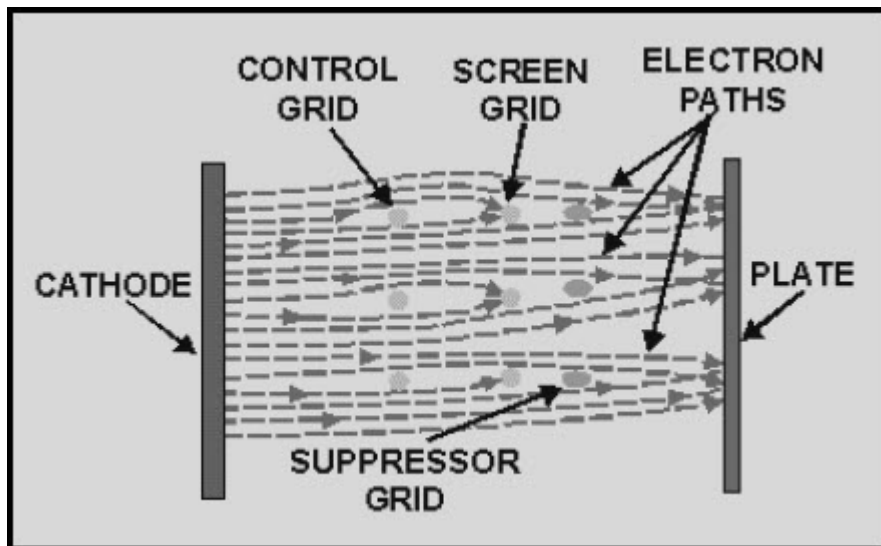

Figure 2-5 Electron flow in a power pentode

NEETS MODULE 6-Electronic Emission, Tubes, and Power Supplies UNCLASSIFIED

This arrangement of grids offers few obstacles to electron flow. Electrons will flow in "sheets" between the grid wires to the plate. The effect is to allow more of the electrons leaving the cathode to reach the plate. Thus, the tube has the advantage of high power output and high efficiency. An added advantage to this type of grid arrangement is high-power sensitivity. This means that the tube can respond to much smaller input signals than the conventional electron tube. The reason for this is obvious; many more electrons reach the plate from the cathode. Therefore, large plate currents can be obtained from relatively weak input signals.

Another type of power amplifier tube that is similar to the power pentode is the **BEAM POWER TUBE**. Beam power tubes have the same grid arrangement as the power pentodes. In addition, they use a set of beam-forming plates to force the electron stream into concentrated beams. Figure 2-6 depicts the internal construction of a beam-forming tube and its schematic representation.

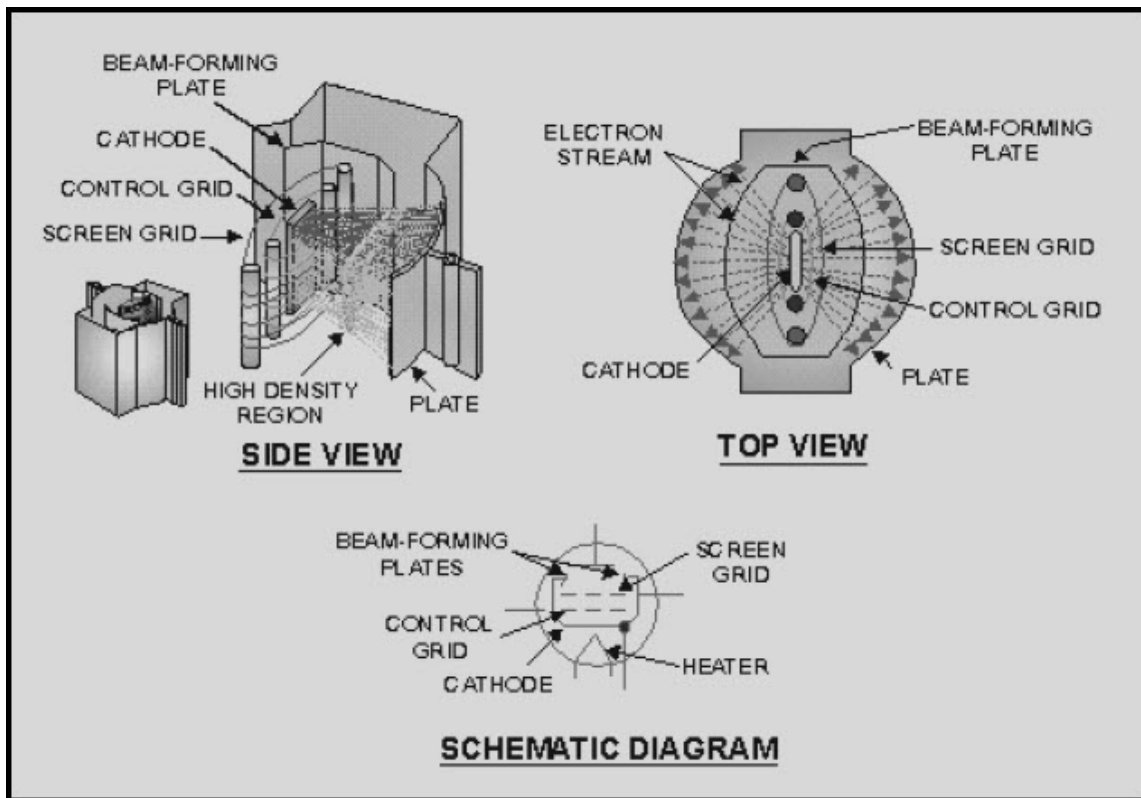

Figure 2-6 The beam-power tube

NEETS MODULE 6-Electronic Emission, Tubes, and Power Supplies

UNCLASSIFIED

Notice that the beam-forming plates surround the grids and their supporting structures and are internally connected to the cathode. This internal connection ensures that the beam-forming plates are at the same negative potential as the cathode. Electrons that are emitted from the sides of the cathode are repelled from the grid supports and into the electron stream by the negative charge on the beam-forming plates. Electrons pass to the plate through the spaces between the beam-forming plates and, by doing so, are concentrated into beams. Because the beam-forming plates are at a negative potential, any electrons emitted by secondary emission are repelled back to the plate. The effect of the beam-forming plates is to increase the number of electrons in the electron stream by forcing stray electrons emitted from the sides of the cathode away from the grid supports and into the electron beam. Electrons that are deflected from the grid wires are also forced into the beam. This increases the total current flowing to the plate. For this reason, both beam-forming and power pentodes are suitable for use as power amplifiers.

2.4 VARIABLE-MU TUBES

In most electron-tube circuits, the operating level of a tube is determined by the level of bias. When a negative-bias voltage is applied to the control grid of a tube, with no input signal, the conduction through the tube is reduced; thus the damage to the tube is minimized. There is one drawback to this. Because the control grid is already negatively charged by the bias voltage, the negative alternation of a large input signal will drive the tube into cutoff long before the positive alternation can drive the tube into saturation. Once the negative alternation reaches a certain level (determined by the bias voltage and tube characteristics), the tube simply cuts off. For this reason, conventional tubes, which you previously studied, are called **SHARP-CUTOFF TUBES**. Because of this sharp cutoff, the range of amplification of the conventional tube is limited by the bias voltage and tube characteristics. Once this range is exceeded, the output becomes distorted due to cutoff.

In most applications, the sharp cutoff feature of conventional electron tubes causes no problems. However, in some applications electron tubes are required to amplify relatively large input signals without distortion. For this reason, the variable-mu tube was developed. **VARIABLE-MU TUBES** have the ability to reduce their mu, or (μ), as the input signal gets larger. As the mu (μ) decreases, the likelihood that the tube will be driven into cutoff decreases. (For an amplifier, this may appear to be self-defeating, but it isn't.) The idea is to amplify large input signals as much as possible without causing the tube to cutoff or create distortion. Because of their ability to avoid being driven into cutoff, variable-mu tubes are called **REMOTE-CUTOFF TUBES**. You should be aware, however, that a variable-mu tube can be driven into cutoff, but the amplitude of the input signal required to do so is considerably greater than in conventional sharp-cutoff tubes.

The key to the ability of a variable-mu tube to decrease gain with an increase in the amplitude of the input lies in its grid construction.

NEETS MODULE 6-Electronic Emission, Tubes, and Power Supplies
UNCLASSIFIED

To understand how the unique grid construction of a variable-mu tube works, we will first examine the grid operation of a conventional tube during cutoff. Look at figure 2-7. Here, you see a diagram of a conventional sharp-cutoff triode with zero volts applied to the control grid. In view A, the majority of the electrostatic lines of force leave the positive plate (+) and travel unhindered between the evenly spaced grid wires to the negative cathode (-). Electrons emitted by the cathode travel along these lines from the cathode, through the grid spacings, to the plate.

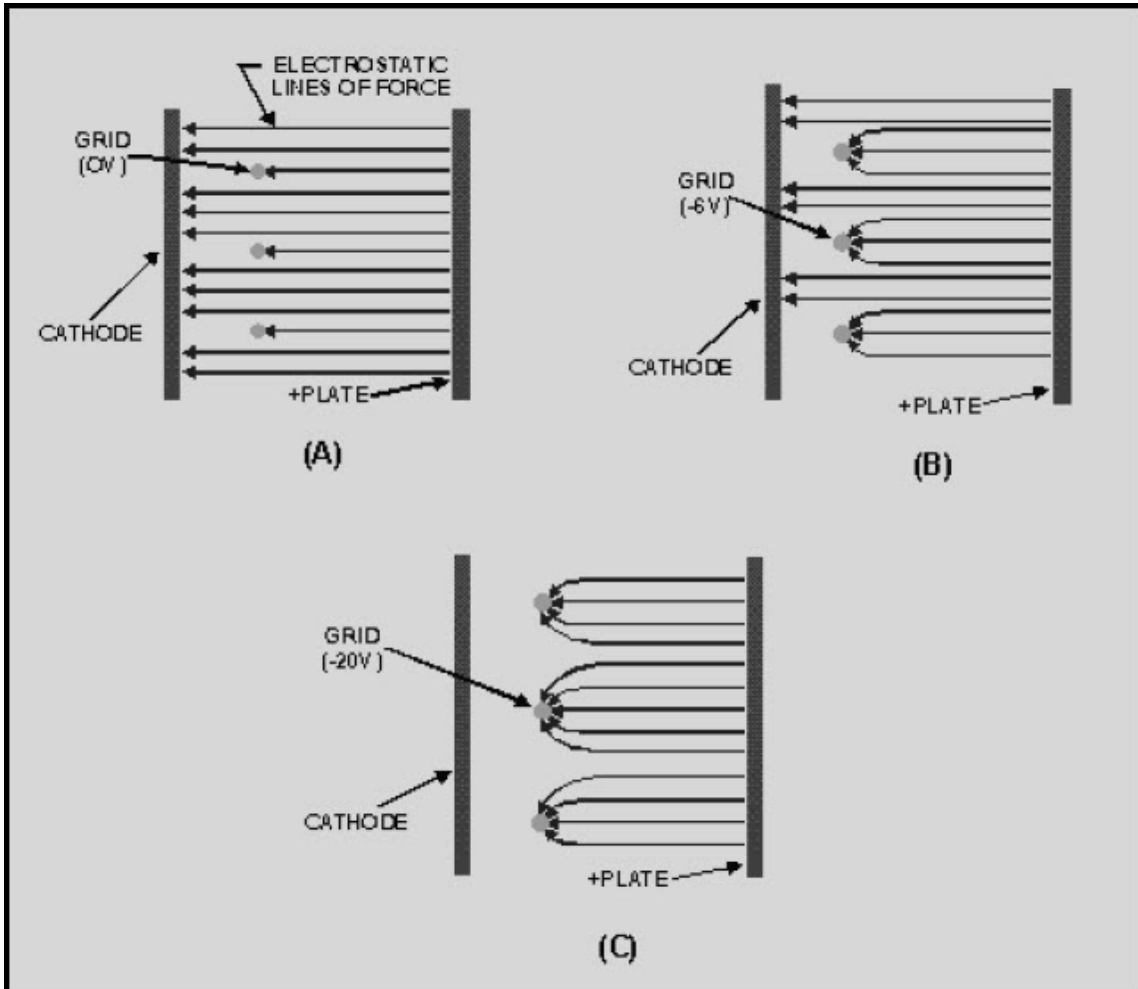

Figure 2-7 Cutoff in a conventional tube

NEETS MODULE 6-Electronic Emission, Tubes, and Power Supplies

UNCLASSIFIED

In view B, a bias voltage of -6 volts is applied to the grid. As you can see, some of the electrostatic lines of force are attracted to the negatively charged grid wires while the rest pass through the grid spacings. Because there are fewer lines of force reaching the cathode, there are fewer paths for electrons to use to reach the plate. As a result, conduction through the tube is decreased.

In view C, the negative potential of the grid has been raised to -20 volts, which drives the tube into cutoff. All of the electrostatic lines of force terminate at the negatively charged grid, instead of continuing on to the cathode. The electrons emitted by the cathode will not feel the electrostatic attractive force of the positively charged plate. Under these conditions, current cannot flow through the tube.

Now look at figure 2-8. Here you see a diagram of a variable-mu, or remote-cutoff, tube. The only difference between the remote-cutoff tube depicted and the sharp-cutoff tube is in the grid wire spacing. In the conventional sharp-cutoff tube, the grid wires are evenly spaced, while in the remote-cutoff tube the grid wires in the middle of the grid are placed relatively far apart. This is shown in view A.

In view B, the control grid is at zero potential (0 volts). Just as in the sharp-cutoff tube, electrons leave the cathode and travel along the lines of electrostatic attraction, through the spaces between the grid wires to the plate. In view C, a bias voltage of -6 volts is applied to the grid. Because of the close spacing of the grid wires at the ends of the grid, electrostatic lines of force at the ends are effectively terminated. The lines of force can only pass between the widely spaced grid wires closer to the center of the grid.

In view D, the same negative potential (-20 volts) is applied to the grid that caused the conventional sharp-cutoff tube discussed earlier to go into cutoff. This voltage is high enough to terminate most of the electrostatic lines of force on the grid wire. But, because of the wide spacing between the center grid wires, some electrostatic lines of force are still able to pass between the center grid wires and reach the cathode. Conduction will still occur in the tube, but at a reduced level. If the grid is driven even more negative, lines of force will be blocked from reaching the cathode, except at the very center of the grid. As you can see, the remote-cutoff tube, by its ability to reduce gain (conduction), handles large signals without going into cutoff. A variable-mu tube such as a 6SK7 with -3 volts applied to the grid will have a transconductance of about 2000 (μ) mhos. If the grid is driven to -35 volts, the transconductance of the tube will decrease to 10 (μ) mhos. This same increase in negative-grid voltage would have driven a conventional tube into cutoff long before the grid reached -35 volts.

NEETS MODULE 6-Electronic Emission, Tubes, and Power Supplies
UNCLASSIFIED

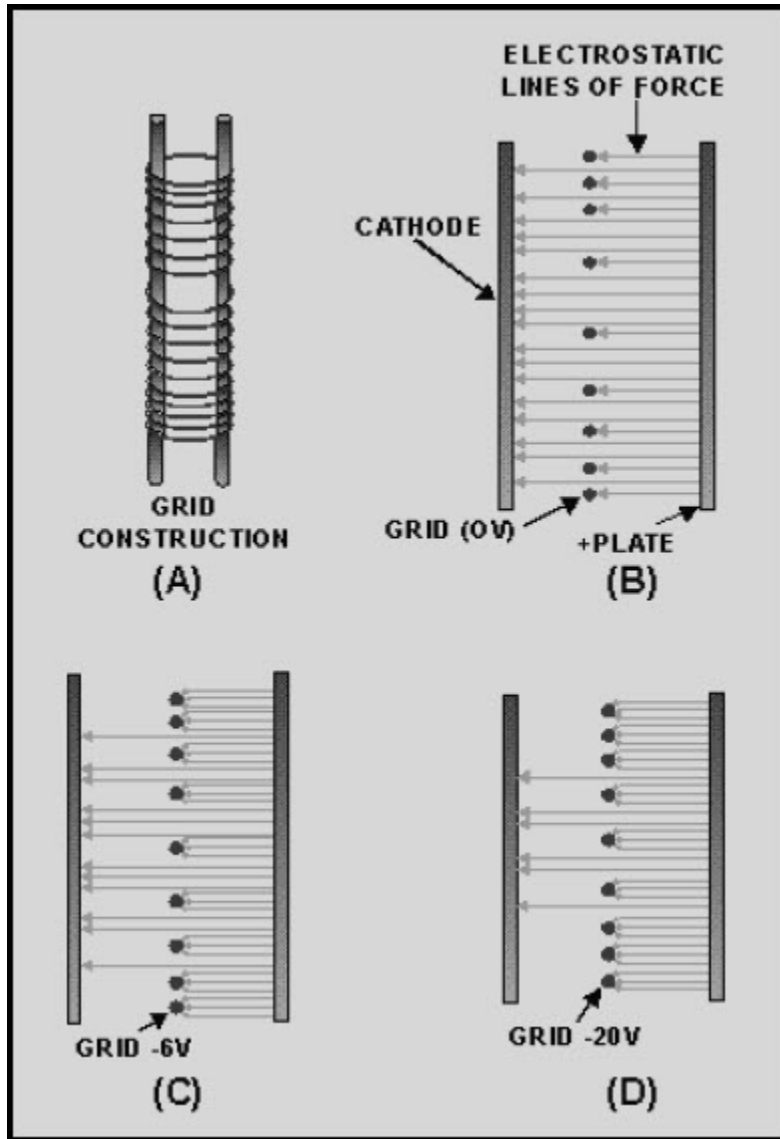

Figure 2-8 Grid operation in a remote-cutoff tube

NEETS MODULE 6-Electronic Emission, Tubes, and Power Supplies
UNCLASSIFIED

Q1. What is the major difference in grid construction between power pentodes and conventional pentodes?

Q2. Beam-forming tubes and power tubes are similar except that power pentodes lack what element?

Q3. What effect does the shielding of the screen grid by the control grid have on plate current in beam-forming tetrodes?

Q4. What effect does a large negative input signal applied to a variable-mu tube have on

a. conduction through the control grid, and

b. gain of the tube?

Q5. Identify the type of electron tube(s) that would be most suitable for the following applications.

a. Power amplifier

b. Voltage amplifier with small signal inputs

c. Low distortion amplifiers for use with large signal inputs

NEETS MODULE 6-Electronic Emission, Tubes, and Power Supplies

UNCLASSIFIED

2.5 SPECIAL UHF TUBES

In the earlier discussion of conventional-electron tubes, you learned some of the limitations of tubes. One of these limitations was that the conventional tube was not able to operate (amplify) at extremely high frequencies such as those used in radar equipment. Even at frequencies lower than those used in radar equipment, problems occur. For example, at ultrahigh frequencies (300 MHz to 3000 MHz), transit time effects make the operation of a conventional-electron tube impossible. For this reason, the special ultrahigh frequency tubes were developed to operate within this frequency range.

Before we discuss the way in which special uhf tubes counter the effects of transit time, you should understand the manner in which transit time affects conventional tubes.

2.5.1 Limitation of Transit Time

We will explain the limitation of transit time by using figure 2-9. In view A, the positive-going alternation of a uhf ac signal is applied to the grid of a conventional-triode tube. The first positive-going alternation reduces the negative bias on the grid, and electrons start to move toward the grid. Since the input is an ultrahigh frequency signal, the majority of the electrons cannot pass the grid before the input signal progresses to the negative alternation. The electrons that have not yet passed the grid are either stopped or repelled back toward the cathode. This is shown in view B. Before these electrons can move very far, the second positive alteration reaches the grid, and causes even more electrons to move from the cathode (view C). At the same time, the electrons that were repelled from the grid toward the cathode by the first negative alternation feel the effect of the positive-going grid. These electrons reverse direction and again move toward the grid. Because these electrons had to first reverse direction, they are now moving slower than the electrons that are attracted from the cathode by the second positive alteration. The result is that the electrons from the cathode catch up to the slower moving electrons and the two groups combine (view C). This action is called **BUNCHING**.

NEETS MODULE 6-Electronic Emission, Tubes, and Power Supplies
UNCLASSIFIED

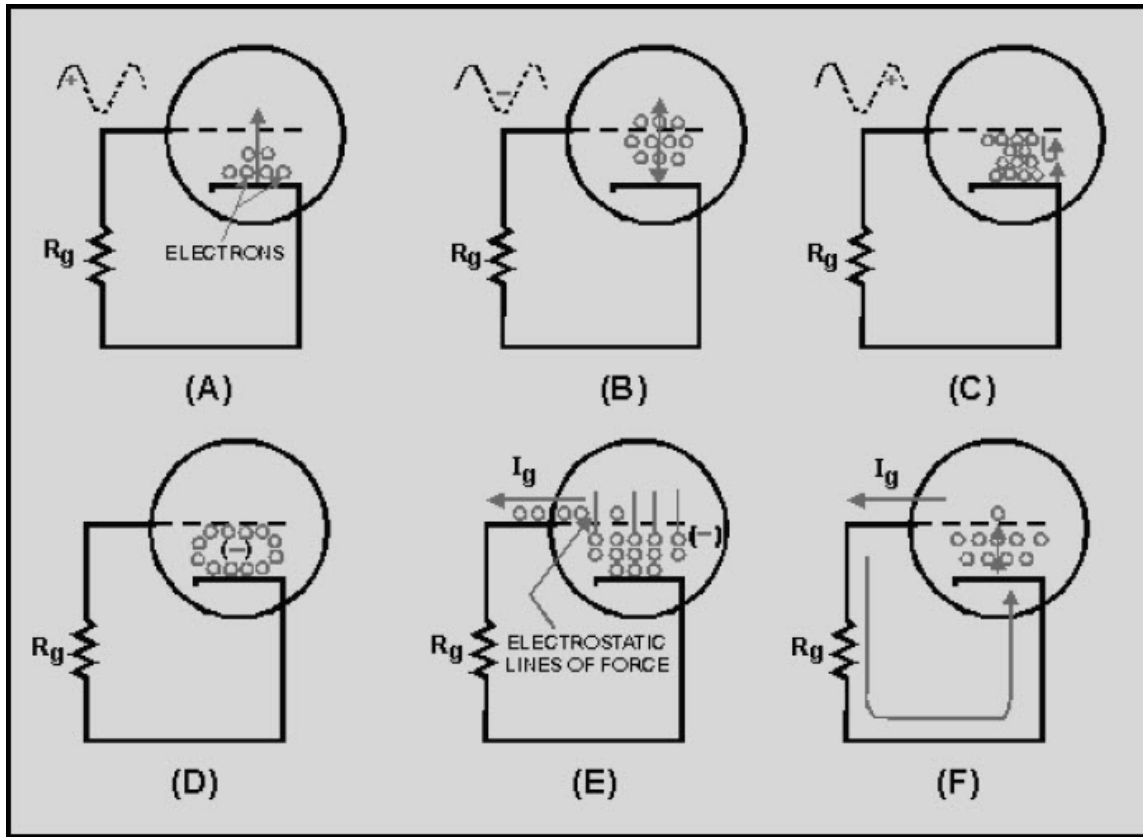

Figure 2-9 Effect of transit time at ultrahigh frequencies

In effect, the area between the grid and cathode becomes highly negatively charged, as shown in view D. This negative charge is surrounded by an electrostatic field. The electrostatic field cuts the grid and repels electrons that are present in the grid. As electrons are forced from the grid, the grid tries to go positive. Unfortunately, this tendency toward a positive charge attracts electrons from the mass or bunched charge. Thus, as an electron is forced from the grid; it is replaced by another from the massed charge. Electrons forced from the grid represent grid current (I_g), as shown in view E. The grid current flows from the grid through R_g , to the cathode, from the cathode, to the massed charge, and back again to the grid. The movement of current in this manner is, in effect, a path for current flow from the cathode to the grid. Because current flows between the cathode and grid, the resistance (rg_k) between these elements is lowered to the point of a short circuit. The grid, in effect, is short circuited to the cathode and ceases to function; and this, in turn, lowers tube efficiency dramatically. This is shown in view F of figure 2-9.

NEETS MODULE 6-Electronic Emission, Tubes, and Power Supplies

UNCLASSIFIED

Transit time may be decreased by reducing the spacing between electrodes or by increasing the electrode voltages, which in turn increases electron velocity through the tube.

The problem with the last solution is that the tube does not present an infinite resistance to current flow. If the operating voltage is raised to an operating potential that is too high, arcing (arc over) occurs between the cathode and the plate and, most likely, will destroy the tube. For this reason, the effects of transit time are reduced in uhf tubes by placing the tube elements very close together.

2.5.2 UHF Tube Types

Uhf tubes have very small electrodes placed close together and often are manufactured without socket bases. By reducing all the physical dimensions of the tube by the same scale, the interelectrode-capacitance and transit time effects are reduced, without reducing the amplification capability of the tube. A disadvantage to this type of tube construction is that the power-handling capability of these tubes is also reduced due to the close placement of the tube elements.

Uhf tubes are placed in three broad categories based on their shape and/or construction; **ACORN**, **DOORKNOB**, and **PLANAR** tubes.

NEETS MODULE 6-Electronic Emission, Tubes, and Power Supplies

UNCLASSIFIED

2.5.2.1 Acorn and Doorknob Tubes

ACORN TUBES, as shown in figure 2-10, are available for use as diodes, triodes, or pentodes. Acorns are very small tubes that have closely spaced electrodes and no bases. The tubes are connected to their circuits by short wire pins that are sealed in the glass or ceramic envelope. Because of their small size, acorn tubes are usually used in low-power uhf circuits.

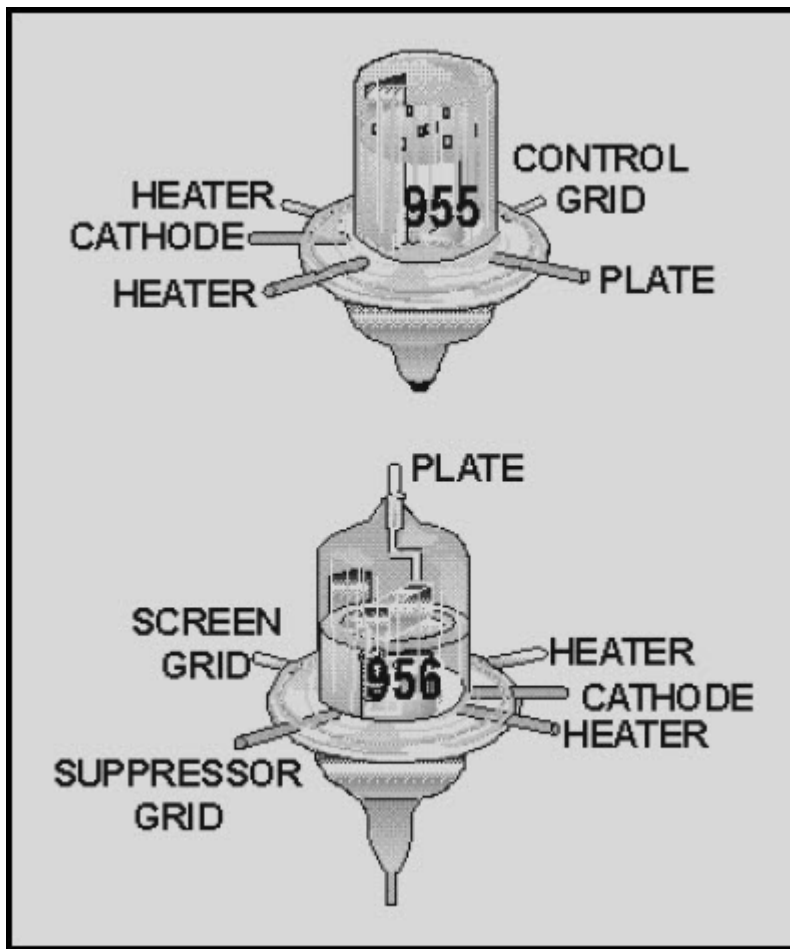

Figure 2-10 Acorn tubes

The **DOORKNOB TUBE** is an enlarged version of the acorn tube. Because of its larger physical size, it can be operated at higher power than the acorn tube.

NEETS MODULE 6-Electronic Emission, Tubes, and Power Supplies
UNCLASSIFIED

2.5.2.2 Planar Tubes

PLANAR TUBES are so named because of their construction. The ordinary (conventional) tube you studied earlier uses concentric construction. This means that each element (cathode, grid, and plate) is cylindrical in shape. The grid is placed over the cathode, and the plate, which is the largest cylinder, is placed over the grid. The result is a tube composed of concentric cylinders like the one shown in figure 2-11. Thus, the name concentric tubes.

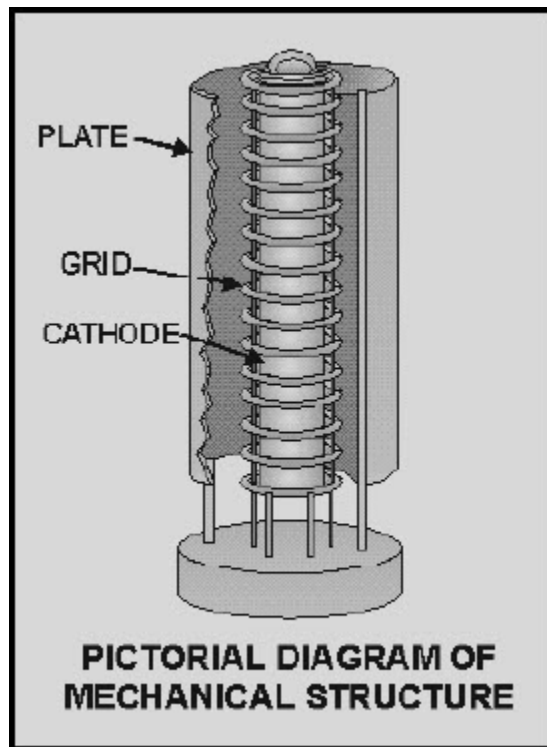

Figure 2-11 Concentric construction of a conventional tube

NEETS MODULE 6-Electronic Emission, Tubes, and Power Supplies UNCLASSIFIED

At ultrahigh frequencies, the problems of producing small tube elements while reducing the spacing between elements become very difficult. Not only are the elements hard to keep parallel with each other during the manufacturing process, but they also have a tendency to warp and sag under normal operating conditions. Since these elements are already as close together as possible, any reduction in element spacing can cause arcing. Therefore, a new type of tube was developed to prevent arcing or element sagging in conventional tubes. This tube is known as the planar tube.

Planar tubes are electron tubes in which the cathode, plate, and grids are mounted parallel to each other. Their physical construction greatly resembles a schematic diagram of a normal tube, as shown in figure 2-12.

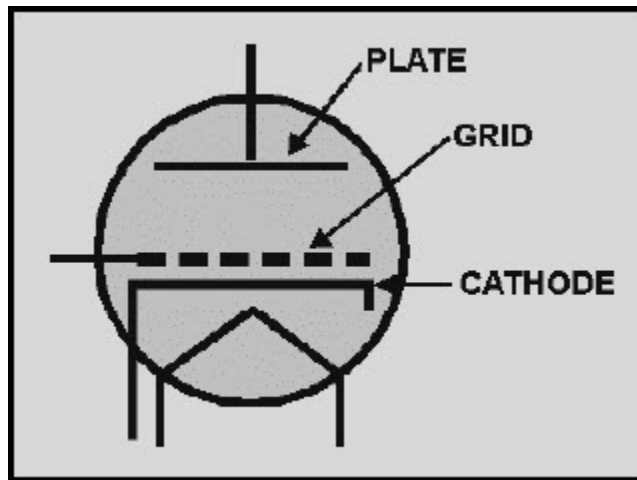

Figure 2-12 Resemblance of a planar tube to a schematic diagram

NEETS MODULE 6-Electronic Emission, Tubes, and Power Supplies
UNCLASSIFIED

A typical planar tube is depicted in figure 2-13. Notice that the tube elements are mounted close to each other and are parallel to one another. The oxide coating of the cathode is applied to the top surface only. Therefore, the emitting surface of the cathode is parallel to the plate and the grid.

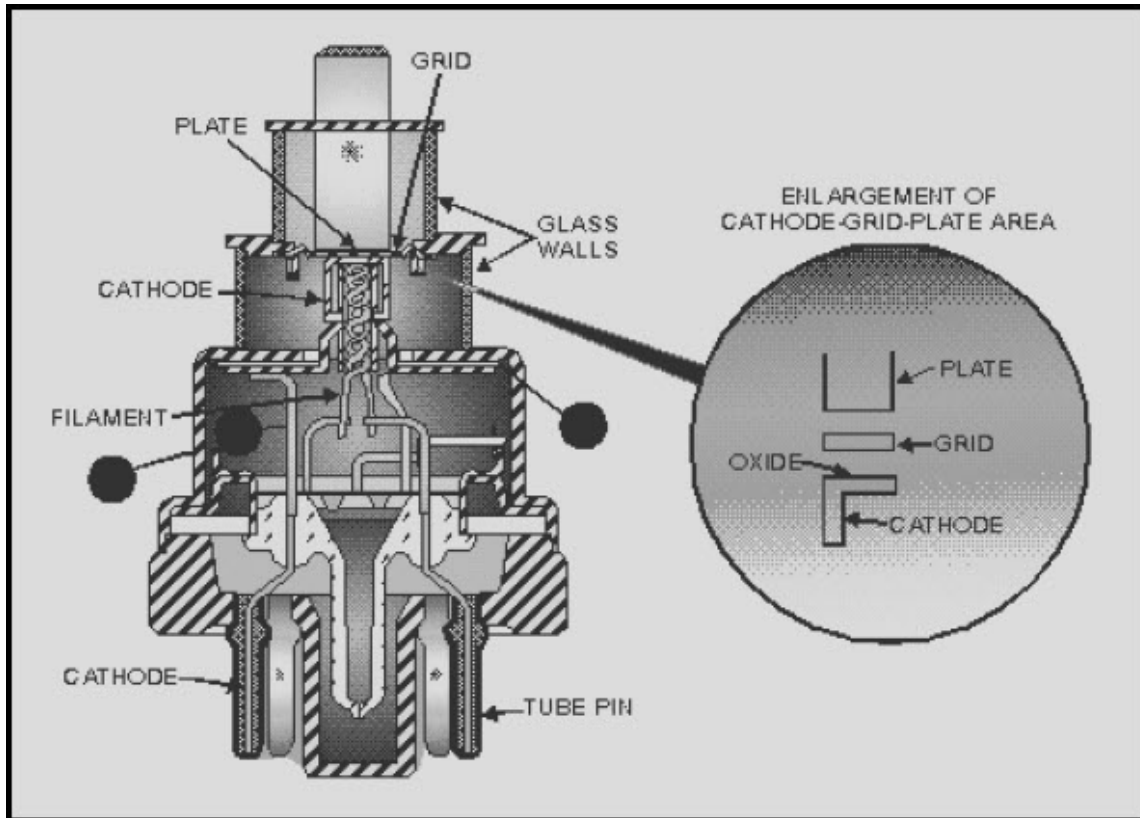

Figure 2-13 Internal structure of a typical planar tube

The plate of the tube consists of a cylindrical stud. This stud-plate construction has two purposes. Its flat lower surface serves as a parallel plate, and its external upper end serves as the external-plate connection from the tube to the circuit.

Because of its construction, the planar tube cannot use the ladder-type grid, with which you are familiar. Instead, the grid, formed into a circle, is composed of a wire mesh similar to that of a common screen door.

NEETS MODULE 6-Electronic Emission, Tubes, and Power Supplies UNCLASSIFIED

The cathode structure is manufactured in two parts. Point A of figure 2-13 is the metallic shell of the tube and is used to couple (or connect) unwanted radio frequency signals from the cathode to ground. This connection is not, however, a direct coupling. The wafer at point C of figure 2-13 is composed of mica, which serves as a dielectric. The lower extension of the cathode serves as one plate of the capacitor, while the other plate is formed from the flattened upper portion of the cathode connector ring. The cathode has a direct connection to the tube pin through the connector labeled point B. You might think that this is a rather complicated method to connect the cathode to a circuit, but it serves a purpose. At high frequencies, the wiring of a circuit can pick up radio frequency signals and retransmit them. If the wiring involved happens to be the wiring used to supply dc voltages to the circuit, all the tubes in the circuit will receive the signal. The result will be massive distortion throughout the circuit.

The problem can be eliminated by isolating the dc and radio frequency circuits from each other. In planar tubes, this is fairly simple. The point A ring is grounded. Any rf signals that the cathode may pick up through tube conduction are grounded or shorted to ground through the capacitive coupling with the point A shell. In other words, the point A shell (capacitive ground) serves the same function as the bypass capacitor in a cathode-biased circuit. Because the capacitor will not pass dc, bias voltages can be applied to the cathode through the tube pins.

Notice the external shape of the planar tube in figure 2-13. The tube is composed of five sections, or cylinders. As you go from the top to the bottom, each cylinder increases in diameter. Because of this piled cylinder construction, the tube resembles a lighthouse, and is therefore known as a **LIGHTHOUSE TUBE**.

Another type of planar tube is shown in figure 2-14. This type of tube, because of its external appearance, is called an **OILCAN TUBE**. The major difference between it and the lighthouse tube is the addition of cooling fins to allow it to handle more power than the lighthouse tube. Because of their planar construction, both types of tubes are capable of handling large amounts of power at uhf frequencies.

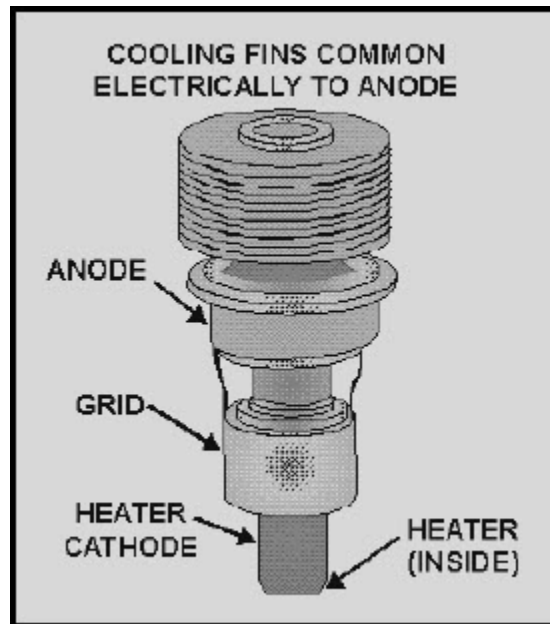

Figure 2-14 Oilcan planar tube

NEETS MODULE 6-Electronic Emission, Tubes, and Power Supplies UNCLASSIFIED

Q6. What effect does transit time have on a conventional triode operated at uhf frequencies?

Q7. How do uhf tubes counter the effects of transit time?

Q8. Why can acorn and doorknob tubes NOT handle large amounts of power?

Q9. What type of uhf tube was developed to handle large amounts of power?

2.6 GAS-FILLED TUBES

You know that great effort is made to produce a perfect vacuum within electron tubes. But, even the best vacuum pumps and getters cannot remove all of the air molecules. However, the chances of an electron hitting a molecule in a near-vacuum are very slim because of the great distance between the molecules, compared to the size of the electron. An electron can pass between two molecules of air inside the tube as easily as a pea could pass through a circle with a diameter equal to that of the earth!

In some tubes, the air is removed and replaced with an inert gas at a reduced pressure. The gases used include mercury vapor, neon, argon, and nitrogen. Gas-filled tubes, as they are called, have certain electrical characteristics that are advantageous in some circuits. They are capable of carrying much more current than high-vacuum tubes, and they tend to maintain a constant **IR** drop across their terminals within a limited range of currents. The principle of operation of the gas-filled tube involves the process called ionization.

NEETS MODULE 6-Electronic Emission, Tubes, and Power Supplies

UNCLASSIFIED

2.6.1 Electrical Conduction in Gas Diodes

An operating gas-filled tube has molecules, ions, and free electrons present within the envelope. In a gas-filled diode, the electron stream from the hot cathode encounters gas molecules on its way to the plate. When an electron collides with a gas molecule, the energy transmitted by the collision may cause the molecule to release an electron. This second electron then may join the original stream of electrons and is capable of freeing other electrons. This process, which is cumulative, is a form of ionization. The free electrons, greatly increased in quantity by ionization, continue to the plate of the diode. The molecule which has lost an electron is called an ion and bears a positive charge. The positive ions drift toward the negative cathode and during their journey attract additional electrons from the cathode.

The velocity of the electrons traveling toward the plate varies directly with the plate voltage. If the plate voltage is very low, the gas-filled diode acts almost like an ordinary diode except that the electron stream is slowed to a certain extent by the gas molecules. These slower-moving electrons do not have enough energy to cause ionization when they hit the gas atoms. After the plate voltage is raised to the proper level of conduction, the electrons have enough energy to cause ionization when they hit the gas molecules. The plate potential at which ionization occurs is known as the **IONIZATION POINT**, or **FIRING POTENTIAL**, of a gas tube. If the plate voltage is reduced after ionization, it can be allowed to go several volts below the firing potential before ionization (and hence, high-plate current) will cease. The value of the plate voltage (E_p) at which ionization stops is called the **DEIONIZATION POTENTIAL**, or **EXTINCTION POTENTIAL**. The firing point is always at a higher plate potential than the deionization point.

2.6.2 Gas Triode

The point at which the gas ionizes can be controlled more accurately by inserting a grid into the gas diode. A negative voltage on the grid can prevent electrons from going to the plate, even when the plate voltage is above the normal firing point. If the negative-grid voltage is reduced to a point where a few electrons are allowed through the grid, ionization takes place. The grid immediately loses control, because the positive ions gather about the grid wires and neutralize the grid's negative charge. The gas triode then acts as a diode. If the grid is made much more negative in an effort to control the plate current, the only effect is that more ions collect about the grid wires—tube continues to conduct as a diode. Only by removing the plate potential or reducing it to the point where the electrons do not have enough energy to produce ionization will tube conduction and the production of positive ions stop. Only after the production of positive ions is stopped will the grid be able to regain control.

NEETS MODULE 6-Electronic Emission, Tubes, and Power Supplies UNCLASSIFIED

Such gas-filled triodes are known as **THYRATRONS**. Thyratrons are used in circuits where current flow in the thyratrons output circuit is possible only when a certain amount of voltage is present on the thyratrons grid. The flow of plate current persists even after the initiating grid voltage is no longer present at the grid, and it can be stopped only by removing or lowering the plate potential. The symbols for the gas-filled diode, the voltage regulator, and the thyatron are the same as those for high-vacuum tubes except that a dot is placed within the envelope circle to signify the presence of gas. Some examples of gas-filled tube schematic symbols are shown in figure 2-15.

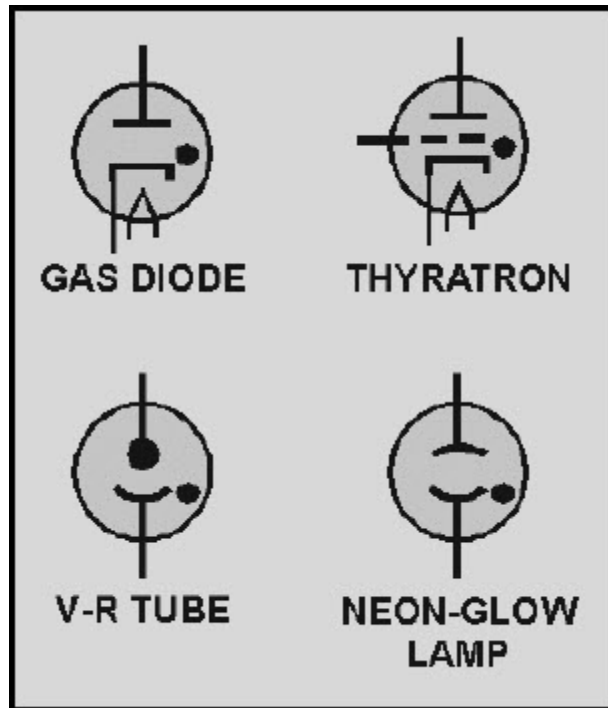

Figure 2-15 Schematic diagram of gas-filled tubes

Before leaving this section, you should be aware of one precaution associated with mercury-vapor tubes. The mercury vapor is not placed in the tube as a vapor; instead a small amount of liquid mercury is placed in the tube before it is sealed. When the liquid mercury comes in contact with the hot filament, the mercury vaporizes.

To ensure that the mercury has vaporized sufficiently, the filament voltage must be applied to mercury-vapor tubes for at least 30 seconds before the plate voltage is applied. If vaporization is incomplete, only partial ionization is possible. Under these conditions, the application of plate voltage results in a relatively high voltage drop across the tube (remember $E = I \times R$), and the positive ions present are accelerated to a high velocity in the direction of the cathode.

NEETS MODULE 6-Electronic Emission, Tubes, and Power Supplies

UNCLASSIFIED

As the ions strike the cathode, they tear away particles of the emitting surface, usually causing permanent damage to the cathode and the tube. When the mercury is completely vaporized, the action of the gas is such that the voltage drop across the tube can never rise above the ionization potential (about 15 volts). At this low potential, positive-ion bombardment of the cathode does not result in damage to the emitting surface.

Generally, when gas-filled tubes are in the state of ionization, they are illuminated internally by a soft, blue glow. This glow is brightest in the space between the electrodes and of lesser intensity throughout the remainder of the tube envelope. This glow is normal and must not be confused with the glow present in high-vacuum tubes when gases are present. A high-vacuum tube with a bluish glow is gassy and should be replaced. The ionization of these gases will distort the output of the tube and may cause the tube to operate with much higher plate current than it can carry safely.

2.7 COLD-CATHODE TUBES

The cold-cathode, gas-filled tube differs from the other types of gas-filled tubes in that it lacks filaments. Thus, its name "**COLD-CATHODE TUBE**." In the tubes covered in this text thus far, thermionic emission was used to send electrons from the cathode to the plate. This conduction of electrons can be caused in another manner. If the potential between the plate and the cathode is raised to the point where tube resistance is overcome, current will flow from the cathode whether it is heated or not. In most applications in electronics, this method is not used because it is not as efficient as thermionic emission. There are two applications where cold-cathode emission is used. The first application you are already familiar with, although you may not be aware of it. Every time you look at a neon sign you are watching a cold-cathode tube in operation. Thus, the first application of cold-cathode tubes is for visual display. You are also familiar with the reason for this visual display. In the *NEETS* module on matter and energy, we explained that when energy is fed into an atom (neon in this case), electrons are moved, or promoted, to higher orbits. When they fall back, they release the energy that originally lifted them to their higher orbits. The energy is in the form of light. Cold-cathode tubes are also used as **VOLTAGE REGULATORS**. Because voltage regulators will be dealt with extensively in the next chapter, we will not cover their operation now. At this point, you only need to understand that a cold-cathode tube has the ability to maintain a constant voltage drop across the tube despite changes of current flow through the tube. The tube does this by changing resistance as current flow varies.

NEETS MODULE 6-Electronic Emission, Tubes, and Power Supplies UNCLASSIFIED

Examine figure 2-16. Here you see a cold-cathode tube connected to a variable voltage source. The variable resistor r_{kp} does not exist as a physical component, but is used to represent the resistance between the cathode and the plate. Most cold-cathode tubes have a firing point (ionizing voltage) at about 115 volts. Thus, the tube in view A of the figure is below the firing point. Because the tube lacks thermionic emission capabilities, no current will flow and the tube will have a resistance (r_{kp}) near infinity. The potential difference between the plate and ground under these conditions will be equal to the source (E_{bb}) voltage, as shown on the voltmeter.

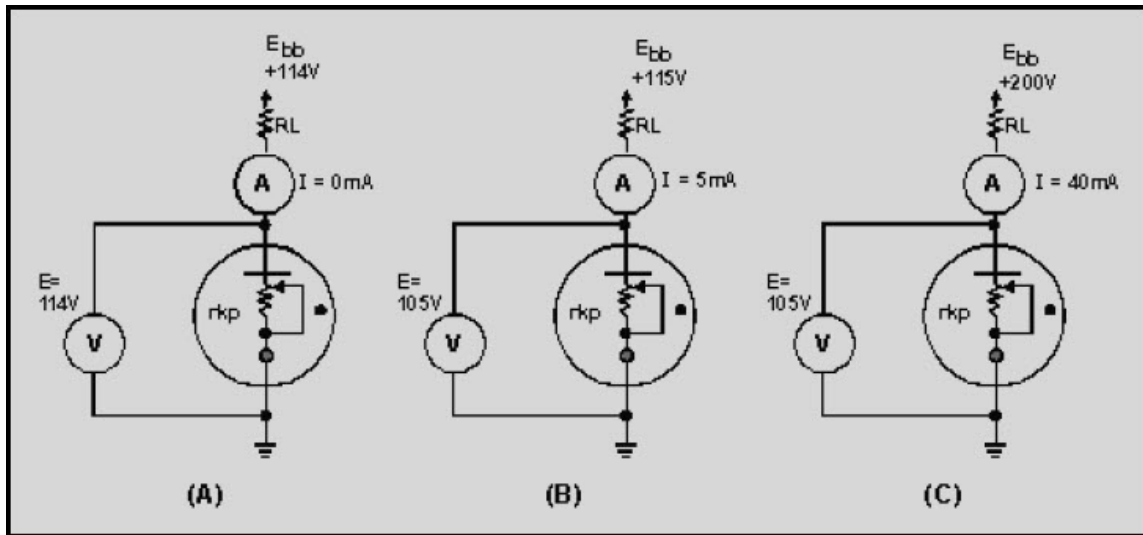

Figure 2-16 Cold-cathode tube operation

In view B, the source voltage has been raised to the firing point of 115 volts. This causes the gas to ionize and 5 milliamperes of current will flow through the tube. Because the tube represents a resistance (r_{kp}), voltage will be dropped across the tube; in this case, 105 volts. The plate-load resistor (R_L) will drop the remaining 10 volts. The resistance of the tube at this time will be equal to:

$$r_{kp} = \frac{E}{I}$$

$$r_{kp} = \frac{105 \text{ volts}}{.005 \text{ amperes}}$$

$$r_{kp} = 21 \text{ kohms}$$

NEETS MODULE 6-Electronic Emission, Tubes, and Power Supplies
UNCLASSIFIED

In view C, the source voltage has been raised to 200 volts. This will cause more gas in the tube to ionize and 40 milliamperes of current to flow through the tube. The increased ionization will lower the resistance of the tube (r_{kp}). Thus, the tube will still drop 105 volts. The tube's resistance (r_{kp}) at this time will be equal to:

$$r_{kp} = \frac{E}{I}$$

$$r_{kp} = \frac{105 \text{ volts}}{40 \text{ milliamperes}}$$

$$r_{kp} = 2.625 \text{ kohms}$$

As you can see, increasing the current flow will cause more ionization in the tube and a corresponding decrease in the tube's resistance. Because of this, the tube will always have a constant voltage drop between its plate and cathode throughout its operating range.

Q10. What are two advantages that gas-filled tubes have over conventional electron tubes?

Q11. Once ionization has occurred in a thyratron, what control does the control grid have over the tube's operation?

Q12. What precautions should be exercised when using mercury-vapor thyratrons?

Q13. Cold-cathode tubes can be used as voltage regulators because of what characteristic?

NEETS MODULE 6-Electronic Emission, Tubes, and Power Supplies

UNCLASSIFIED

2.8 THE CATHODE-RAY TUBE (CRT)

Although you may not be aware of this fact, the **CATHODE-RAY TUBE** shown in figure 2-17 is, in all probability, the one tube with which you are most familiar. Before you started your study of electronics, you probably referred to cathode-ray tubes as picture tubes. The cathode-ray tube (**CRT**) and the picture tube of a television set are one and the same.

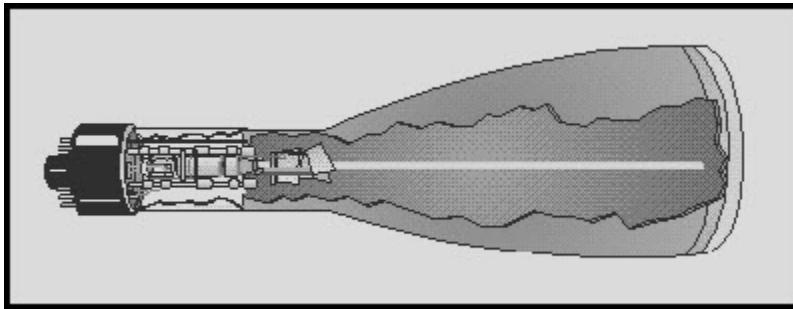

Figure 2-17 Cutaway view of a typical CRT

Cathode-ray tubes are used in more applications than just television. They can be considered as the heart of the many types of information.

Cathode-ray tubes have one function that cannot be duplicated by any other tube or transistor; namely, they have the ability to convert electronic signals to visual displays, such as pictures, radar sweeps, or electronic wave forms.

All CRT's have three main elements: an electron gun, a deflection system, and a screen. The electron gun provides an electron beam, which is a highly concentrated stream of electrons. The deflection system positions the electron beam on the screen, and the screen displays a small spot of light at the point where the electron beam strikes it.

NEETS MODULE 6-Electronic Emission, Tubes, and Power Supplies UNCLASSIFIED

2.8.1 The Electron Gun

The **ELECTRON GUN** is roughly equivalent to the cathodes of conventional tubes. The cathode of the electron gun in the CRT is required not only to emit electrons, but also to concentrate emitted electrons into a tight beam. In the electron tubes that you have studied, the cathode was cylindrical and emitted electrons in all directions along its entire length. This type of cathode is not suitable for producing a highly concentrated electron-beam. The cathode of the CRT consists of a small diameter nickel cap. The closed end of the cap is coated with emitting material. This is shown in figure 2-18. Because of this type of construction, electrons can only be emitted in one direction. Notice that the emitted electrons shown in figure 2-18 are leaving the cathode at different angles. If these electrons were allowed to strike the screen, the whole screen would glow. Since the object of the electron gun is to concentrate the electrons into a tight beam, a special grid must be used. This special grid is in the form of a solid metal cap with a small hole in the center. The grid is placed over the emitting surface of the cathode and charged negatively in relation to the cathode.

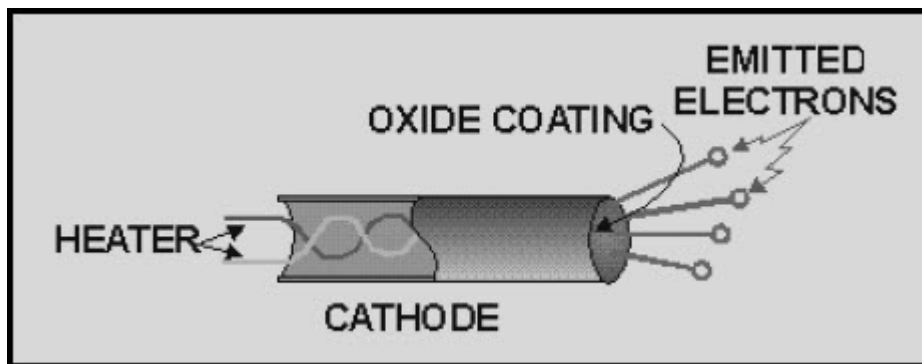

Figure 2-18 CRT cathode

NEETS MODULE 6-Electronic Emission, Tubes, and Power Supplies UNCLASSIFIED

The dotted lines represent the direction of cathode emitted electron repulsion, as shown in figure 2-19. Since all emitted electrons leave the cathode (point C), their paths can be identified. An electron attempting to travel from point C to point B (downward) will instead follow the path from point C to point E to point P. Consider an electron leaving from C in the direction of point A (upward). Its path will be curved from point C to point P by electrostatic repulsion. These curving electron paths are due to the negative potential of the grid coupled with the high positive potential of the anode. The potential of the anode attracts electrons out of the cathode-grid area past point P toward the screen. The grid potential may be varied to control the number of electrons allowed to go through the control-grid opening. Since the brightness or intensity of the display depends on the number of electrons that strike the screen, the control grid is used to control the brightness of the CRT.

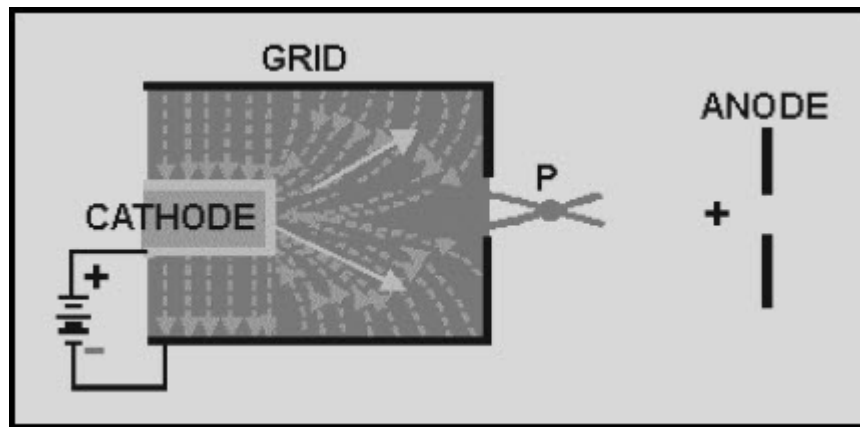

Figure 2-19 Operation of the CRT grid

The proper name, **BRIGHTNESS CONTROL**, is given to the potentiometer used to vary the potential applied to the control grid. The control grid actually serves as an electron lens. It is this electronic lens that you adjust when you turn up the brightness control on your TV set. Notice that the effect of the grid is to focus the electron beam at point P in figure 2-19.

NEETS MODULE 6-Electronic Emission, Tubes, and Power Supplies UNCLASSIFIED

After passing point P, the electrons start to spread out, or diverge, again. Therefore, it becomes necessary to provide some additional focusing to force the electrons into a tight beam again. This is done by two additional positively-charged electrodes as shown in figure 2-20. The first electrode is commonly called the **FOCUSING ANODE**. Generally, the focusing anode is charged a few hundred volts positive with respect to the cathode. Electrons emitted by the cathode are attracted to the focusing anode. This is the reason that they travel through the small hole in the grid. The second electrode, called the **ACCELERATING ANODE**, is charged several thousand volts positive in relation to the cathode. Any electrons approaching the focusing anode will feel the larger electrostatic pull of the accelerating anode and will be bent through the opening in the focusing anode and will travel into the area labeled D. You might think that once an electron is in this region, it is simply attracted to the accelerating anode and that is the end of it. This does not happen. Because the accelerating anode is cylindrical in shape, the electrostatic field radiating from it is equal in all directions. Thus, an electron is pulled in all directions at once, forcing the electron to travel down the center of the tube. Then, the electron is accelerated into the accelerating anode. Once it passes the mid-point (point E), it feels the electrostatic attraction from the front wall of the accelerating anode, which causes it to move faster toward the front. Once the electron reaches point F, equal electrostatic attraction on either side of the opening squeezes it through the small opening in the front of the anode. From there, it is joined by millions of other electrons and travels in a tight beam until it strikes the screen (point S).

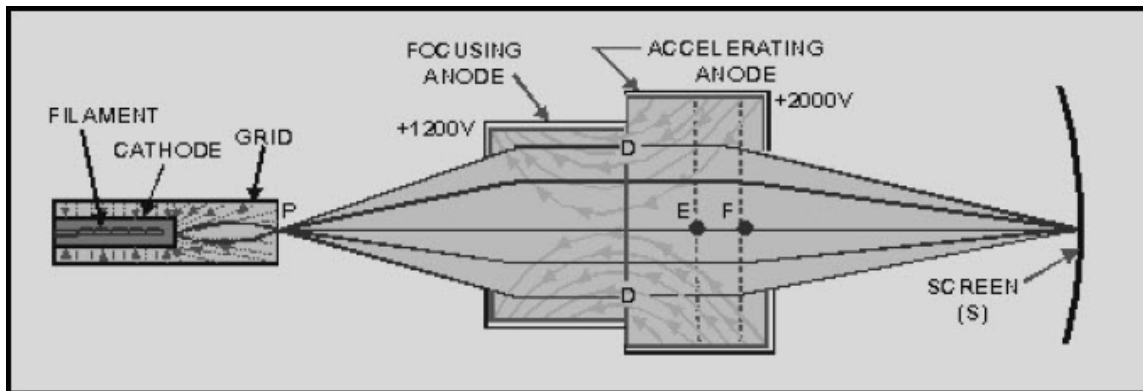

Figure 2-20 Electron-beam formation In a CRT

NEETS MODULE 6-Electronic Emission, Tubes, and Power Supplies

UNCLASSIFIED

2.8.2 The CRT Screen

The inside of the large end of a CRT is coated with a fluorescent material that gives off light when struck by electrons. This coating is necessary because the electron beam itself is invisible. The material used to convert the electrons' energy into visible light is a **PHOSPHOR**. Many different types of phosphor materials are used to provide different colored displays and displays that have different lengths of **PERSISTENCE** (duration of display).

In one way, the CRT screen is similar to a tetrode vacuum tube. Both suffer from the effects of secondary emission. In order to reach the screen, electrons from the cathode are accelerated to relatively high velocities. When these electrons strike the screen, they dislodge other electrons from the material of the screen. If these secondary emission electrons are allowed to accumulate, they will form a negatively-charged barrier between the screen and the electron beam, causing a distorted image on the CRT screen. The method used to control secondary emission, which you are already familiar with, i.e., a suppressor grid, is not practical in CRT's. Instead, a special coating called an **AQUADAG COATING** is applied to the inside of the tube as shown in figure 2-21. This coating is composed of a conductive material, such as graphite, and has the same high-positive potential applied to it that is applied to the accelerating anode. This allows the aquadag to perform two functions. First, since the aquadag coating is positive, it attracts the secondary emitted electrons and removes them. Second, because the aquadag is operated at a high-positive potential and is mounted in front of the accelerating anode, it aids in the acceleration of electrons toward the screen.

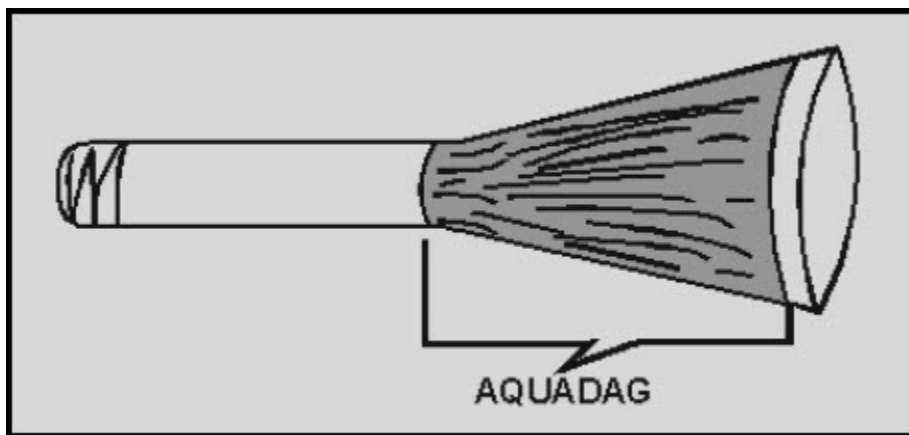

Figure 2-21 Aquadag coating in a CRT

NEETS MODULE 6-Electronic Emission, Tubes, and Power Supplies

UNCLASSIFIED

Before going on, let's review what you have already learned about CRT operation.

1. Electrons are emitted from a specially constructed cathode and move toward the front of the CRT.
2. The number of electrons that leave the area of the cathode is determined by the cap-shaped grid. In addition, the grid concentrates the emitted electrons into a beam.
3. The electron beam is focused and accelerated toward the screen by two electrodes: the focusing anode and the acceleration anode.
4. The electron beam strikes the screen and causes a bright spot to appear at the point of impact.
5. Any electrons released by secondary emission are removed from the tube by the aquadag coating.

2.8.3 Deflection

At this point, you have a bright spot in the center of the CRT screen as shown in figure 2-22. Having watched TV, you know that a TV picture consists of more than just a bright spot in the center of the picture tube. Obviously, something is necessary to produce the picture. That something is called **DEFLECTION**. For the CRT to work properly, the spot must be moved to various positions on the screen. In your TV set for example, the spot is moved horizontally across the CRT face to form a series of tightly packed lines. As each line is displayed, or traced, the electron beam is moved vertically to trace the next line as shown in figure 2-23. This process starts at the top of the tube and ends when the last line is traced at the bottom of the CRT screen. Because the beam is swept very quickly across the CRT and the phosphor continues to glow for a short time after the beam has moved on, you do not see a series of lines, but a continuous picture.

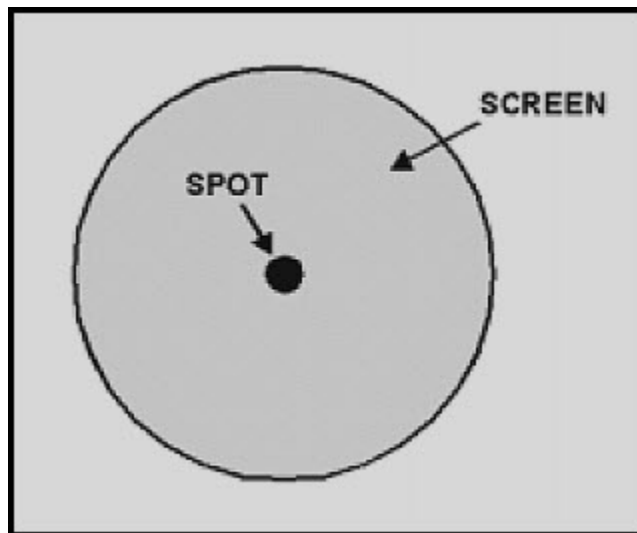

Figure 2-22 Impact of an electron beam on a CRT screen

NEETS MODULE 6-Electronic Emission, Tubes, and Power Supplies
UNCLASSIFIED

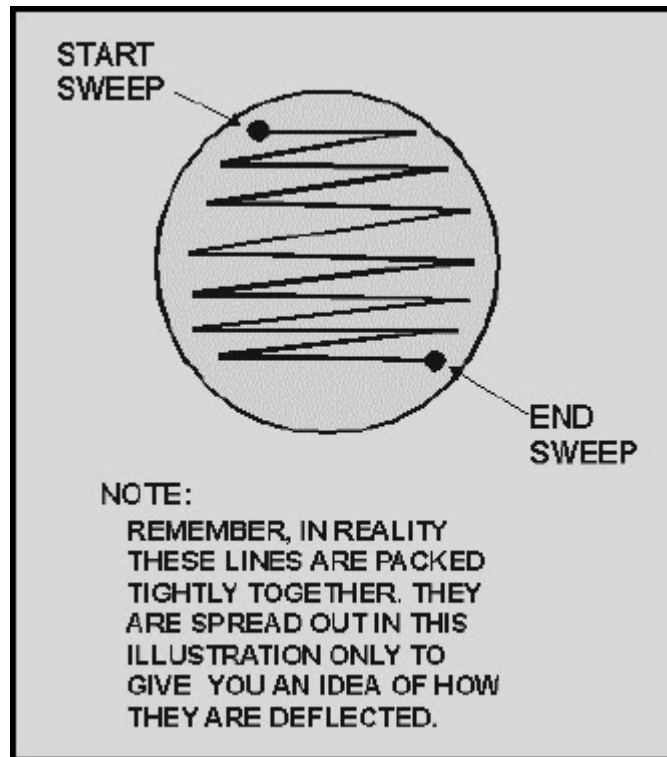

Figure 2-23 Deflection of an electron beam across a TV screen

These same principles also apply to the CRT used in your use of your major tool: the **OSCILLOSCOPE**. Remember, the unique function of a CRT is to convert electronic (and electrical) signals to a visual display. This function of a CRT is used in the oscilloscope to show the waveform of an electronic signal. To help you understand better how an oscilloscope works, we will discuss the type of deflection used in oscilloscopes. Bear in mind that the following discussion is only about deflection; we will cover the actual operation of an oscilloscope in a later *NEETS* module that deals specifically with test equipment.

2.8.3.1 Electrostatic Deflection

As you should know, there are two ways to move an electron (and thus an electron beam): either with a magnetic or with an electrostatic field. Because of this, there are three possible ways to move or deflect an electron beam in a CRT: magnetically, electromagnetically, and electrostatically. All three ways are used in electronics. In general, though, electrostatic and electromagnetic deflection are used most often. Your TV set, for example, uses electromagnetic deflection, while much of the test equipment in the Navy uses electrostatic deflection.

NEETS MODULE 6-Electronic Emission, Tubes, and Power Supplies
UNCLASSIFIED

ELECTROSTATIC DEFLECTION uses principles you are already familiar with. Namely, opposites attract, and likes repel. Look at figure 2-24, view A. Here you see an electron traveling between two charged plates, H_1 and H_2 . As you can see, before the electron reaches the charged plates, called **DEFLECTION PLATES**, its flight path is toward the center of the screen. In view B, the electron has reached the area of the deflection plates and is attracted toward the positive plate, H_2 , while being repelled from the negative plate, H_1 . As a result, the electron is deflected to the right on the inside of the screen. You, the viewer, will see the spot of light on the left side of the CRT face (remember, you are on the opposite side of the CRT screen). This is shown in view C.

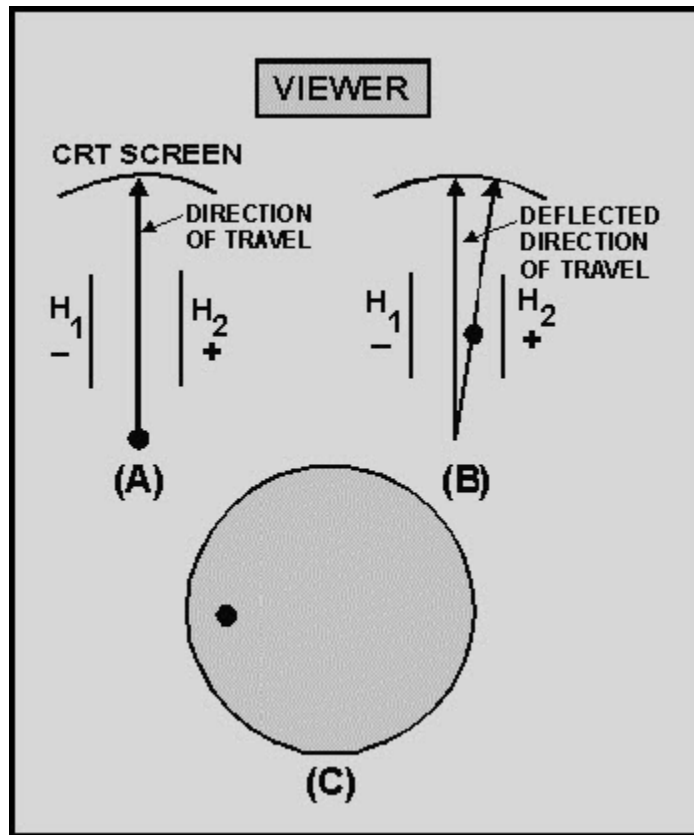

Figure 2-24 Deflection in a CRT

NEETS MODULE 6-Electronic Emission, Tubes, and Power Supplies

UNCLASSIFIED

A spot of light on the left-hand side of the CRT screen, however, is no more useful than a spot of light in the center of the screen. To be useful, this spot will have to be converted to a bright line, called a sweep, across the face of the CRT screen. We will explain the manner in which this is done by using figure 2-25.

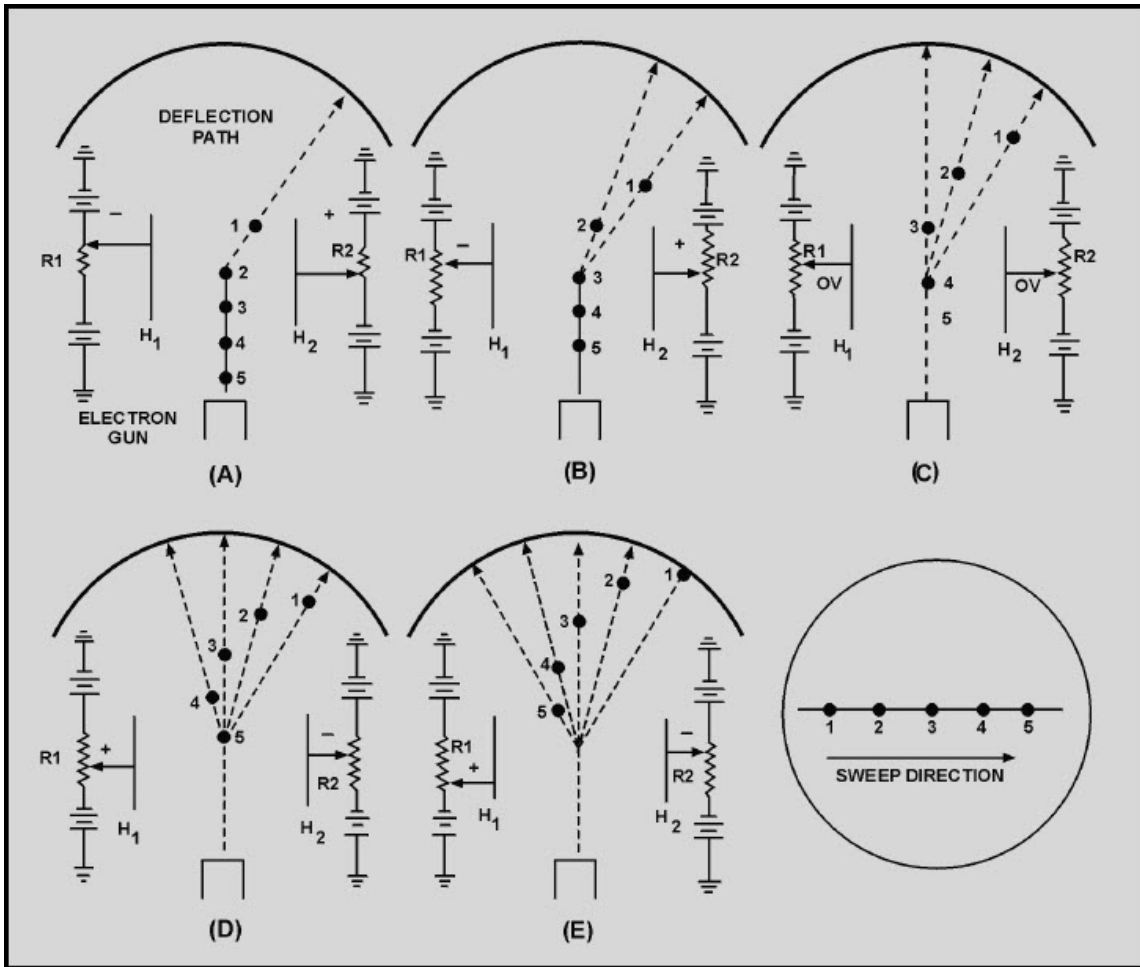

Figure 2-25 Horizontal deflection

In view A, five electrons are emitted in sequence, 1 through 5, by the electron gun. The right deflection plate, H₂, has a large positive potential on it while the left plate, H₁ has a large negative potential on it. Thus, when electron 1 reaches the area of the deflection plates, it is attracted to the right plate while being repelled from the left plate. In view B, electron 2 has reached the area of the deflection plates.

NEETS MODULE 6-Electronic Emission, Tubes, and Power Supplies
UNCLASSIFIED

However, before it arrives, R1 and R2 are adjusted to make the right plate less positive and the left plate less negative. Electron 2 will still be deflected to the right but not as much as electron 1. In view C, electron 3 has reached the area of the deflection plates. Before it gets there, R1 and R2 are adjusted to the mid-point. As a result, both plates have 0 volts applied to them. Electron 3 is not deflected and simply travels to the center of the CRT screen. In view D, electron 4 has reached the area of the deflection plates. Notice that R1 and R2 have been adjusted to make the right plate negative and the left plate positive. As a result, electron 4 will be deflected to the left. Finally, in view E, the left plate is at its maximum positive value. Electron 5 will be deflected to the extreme left. What you see when you are facing the CRT is a bright luminous line, as shown in view E. While this description dealt with only five electrons, in reality the horizontal line across a CRT face is composed of millions of electrons. Instead of seeing five bright spots in a line, you will see only a solid bright line.

In summary, the horizontal line displayed on a CRT or on the face of a television tube is made by sweeping a stream of electrons rapidly across the face of the CRT. This sweeping action, or scanning, is performed by rapidly varying the voltage potential on the deflection plates as the electron stream passes.

NEETS MODULE 6-Electronic Emission, Tubes, and Power Supplies

UNCLASSIFIED

2.8.3.2 Vertical Deflection

As we mentioned earlier, a CRT can be used to graphically and visually plot an electronic signal, such as a sine wave. This is done by using a second set of deflection plates called **VERTICAL-DEFLECTION PLATES**. Examine figure 2-26. You are looking at the front view (facing the screen) of a CRT, back into the tube at the deflection plates. In normal usage, the horizontal plates sweep a straight line of electrons across the screen from left to right while the signal to be displayed is applied to the vertical deflection plates. A circuit of this type is shown in figure 2-27. We will use this figure to explain how a sine wave is displayed. First, however, you need to understand what is happening in view A. The box on the left of the CRT labeled **HORIZONTAL-DEFLECTION CIRCUITS** is an electronic circuit that will duplicate the actions of R1 and R2 used earlier in making up a horizontal line. How it works will be discussed in a later *NEETS* module. Notice T1; the output of this transformer is applied to the vertical-deflection plates. The signals applied to the vertical plates are 180° out of phase with each other. Thus, when one plate is attracting the electron beam, the other will be repelling the electron beam. Because you are only concerned with what happens inside the CRT, this circuitry will be eliminated and only the CRT and its deflection plates will be shown, as in view B.

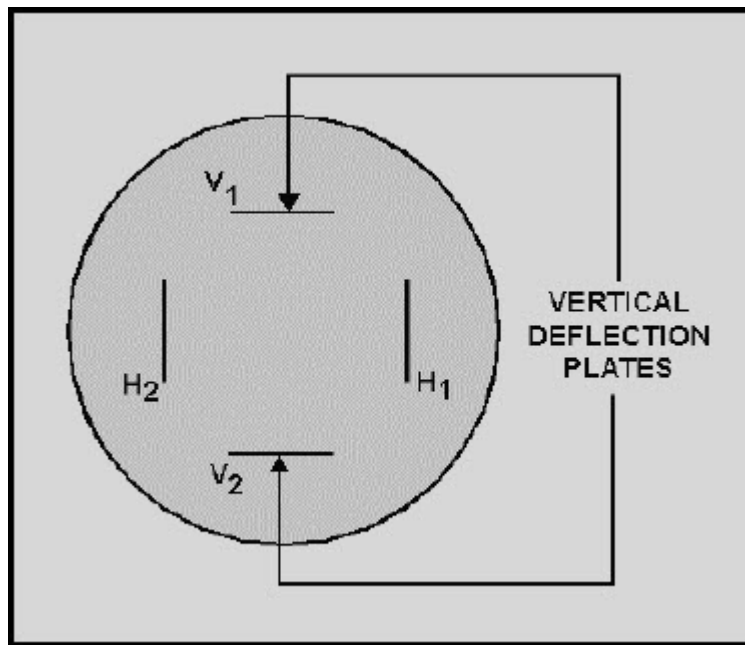

Figure 2-26 Arrangement of deflection plates in a CRT, front view

NEETS MODULE 6-Electronic Emission, Tubes, and Power Supplies
UNCLASSIFIED

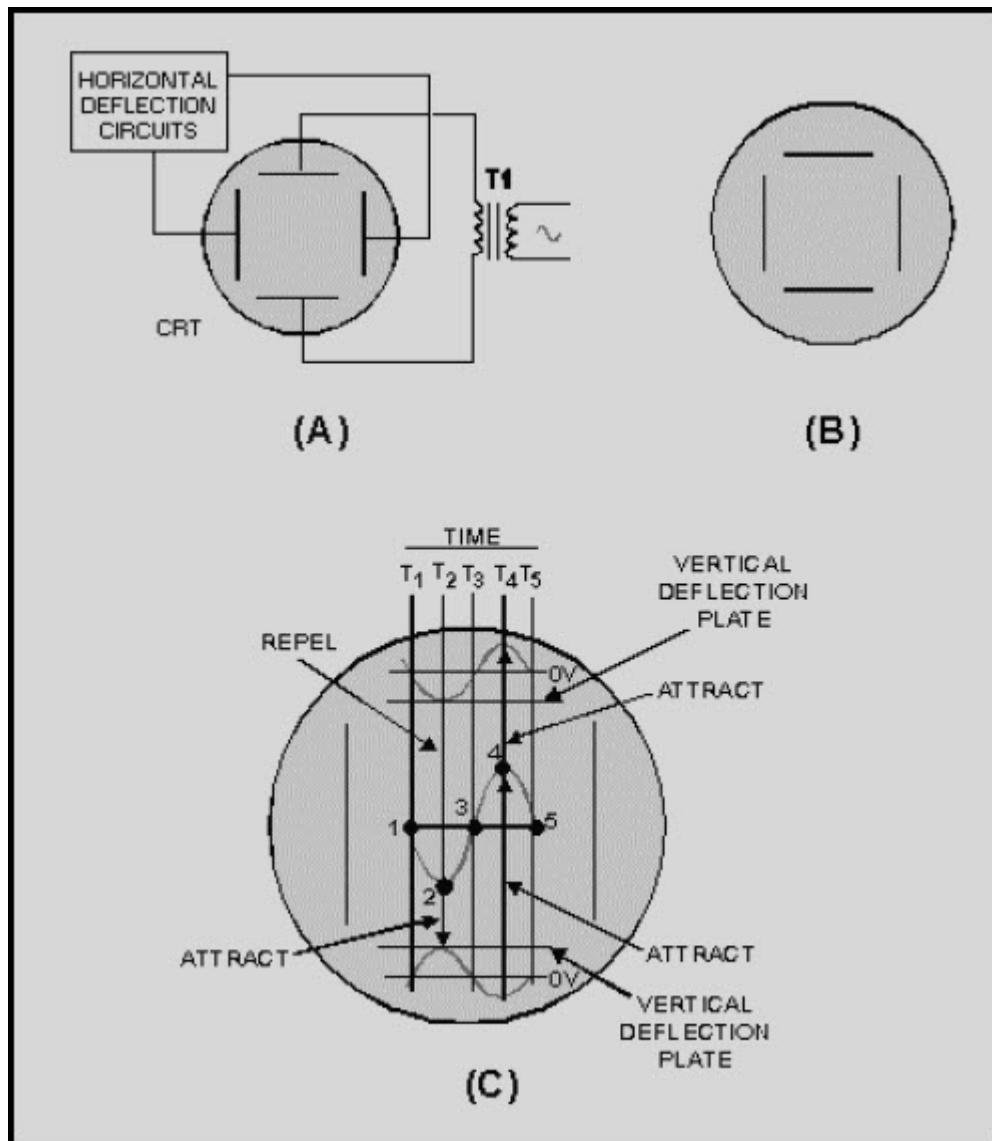

Figure 2-27 Vertical deflection in a CRT

Now look at view C. While this illustration looks complicated, don't let it worry you. You have already analyzed more complicated diagrams. The sine wave in the center of the screen is the signal that will be displayed as a result of the two 180° out-of-phase sine waves applied to the vertical-deflection plates. The five spots on the center sine wave represent the five electrons used to explain horizontal deflection. Only now these electrons will be deflected both vertically and horizontally. Time lines T1 through T5 represent the time when each like-numbered electron reaches the area of the deflection plates. Because you already know how the electron beam is swept or deflected horizontally, we will not discuss horizontal deflection.

NEETS MODULE 6-Electronic Emission, Tubes, and Power Supplies

UNCLASSIFIED

Just remember that from T1 to T5, the electron beam will be continuously moved from your left to your right. Now that you know where everything is on the illustration, you are ready to discover how a sine wave is displayed on a CRT.

At time 1 (T1), the sine waves applied to both vertical-deflection plates are at their null points, or zero volts. As a result, electron 1 is not vertically deflected and strikes the CRT at its vertical center. At time 2 (T2), the sine wave applied to the top plate is at its maximum negative value. This repels electron 2 toward the bottom of the CRT. At the same time, the sine wave applied to the bottom plate is at the most positive value, causing electron 2 to be attracted even further toward the bottom of the CRT. Remember, the beam is also being moved to the left. As a result, electron 2 strikes the CRT face to the right of and below electron 1. At time 3 (T3), both sine waves applied to the vertical-deflection plates are again at the null point, or zero volts. Therefore, there is no vertical deflection and electron 3 strikes the CRT face in the center of the vertical axis. Because the electron beam is still moving horizontally, electron 3 will appear to the right of and above electron 2. At time 4 (T4), the sine wave applied to the top vertical-deflection plate is at its maximum positive value. This attracts electron 4 toward the top deflection plate. The upward deflection of electron 4 is increased by the negative-going sine wave (at time 4) applied to the bottom deflection plate. This negative voltage repels electron 4 upward. Thus, electron 4 strikes the CRT face to the right of and above electron 3. Finally, at time 5 (T5) both input sine waves are again at zero volts. As a result, electron 5 is not deflected vertically, only horizontally. (Remember, the beam is continually moving from right to left.)

While this discussion is only concerned with five electrons, vertical scanning, or deflection, involves millions of electrons in a continuous electron beam. Instead of seeing five spots on the CRT screen, you will actually see a visual presentation of the sine wave input. This was, as you remember, described earlier as the unique feature of the CRT. You may have wondered why so much space in this chapter was taken up with the discussion of the CRT. There are two reasons for this. First, the field of electronics is in a constant state of evolution. Transistors replaced most vacuum tubes. Transistors are being replaced by integrated circuits (ICs). As you progress in your career in electronics, you will find that the equipment you work on will follow this evolution, from transistors to IC chips. Of all the tubes discussed in this text, the CRT is the least likely to be replaced in the near future. Thus, in all probability, whether your career in electronics lasts for only the time you spend with this text or 20 years, the CRT will be your constant companion and co-worker.

The second reason for this rather extensive coverage of the CRT is that, while the CRT has a unique ability, it operates exactly like all the tubes previously discussed.

NEETS MODULE 6-Electronic Emission, Tubes, and Power Supplies
UNCLASSIFIED

2.8.4 Summary of the CRT

This summary will not only review the CRT, but will also point out the similarities between the CRT and other tubes.

Look at figure 2-28. Here you see both a schematic diagram and a pictorial representation of a CRT. Each element is identified by a circuit number. We will review briefly the function of each element in a CRT and its similarity to elements in conventional tubes. This summary will help you tie together everything you have learned about the CRT and electron tubes in general.

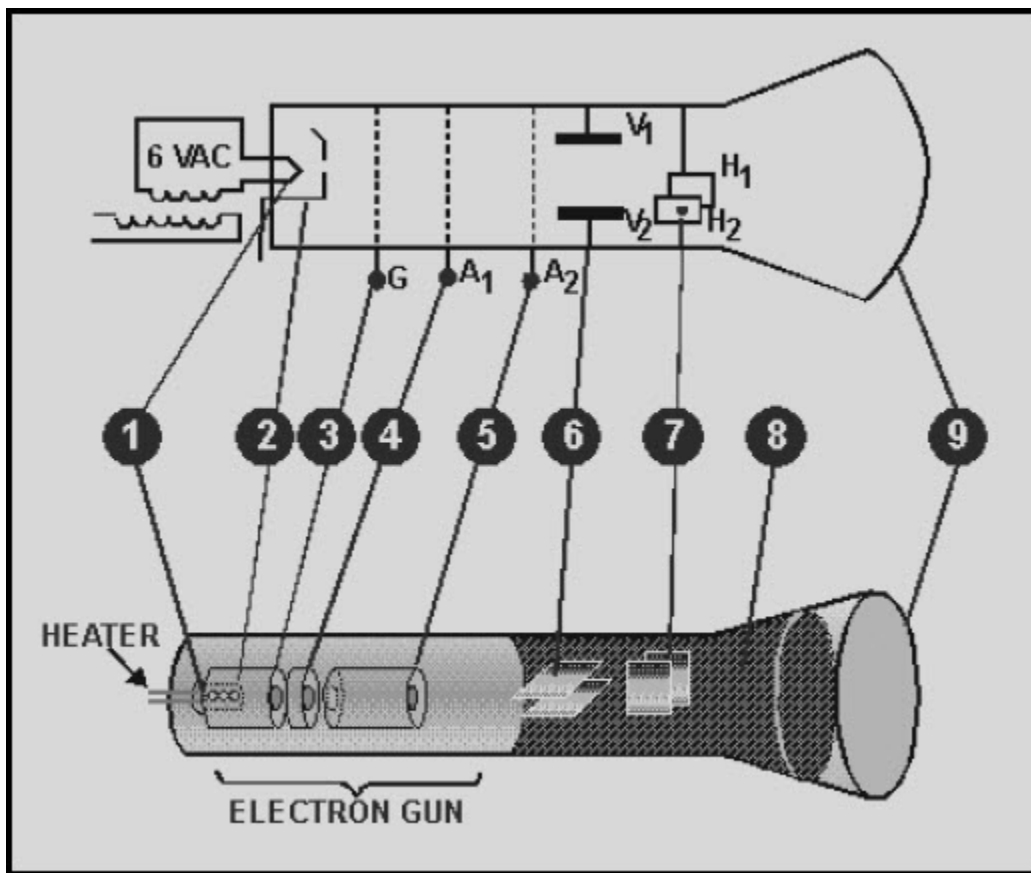

Figure 2-28 Summary of the CRT

NEETS MODULE 6-Electronic Emission, Tubes, and Power Supplies

UNCLASSIFIED

1. The Heater - serves as the source of heat for the cathode in both the CRT and indirectly heated tubes.
2. The Cathode - serves as the source of thermionically emitted electrons in both the CRT and conventional tubes. The major difference is that in the CRT, the cathode is circular in shape and the outer surface is coated to ensure that electron emission is roughly unidirectional.
3. The Control Grid-in both the CRT and conventional vacuum tubes, the control grid controls the number of electrons that will be fired across "the gap." The major difference is in the physical construction. Conventional tubes use a wire-mesh ladder-type grid, while the CRT uses a cap-like grid.
4. The Focusing Anode - in the CRT, this anode serves a dual purpose of attracting electrons from the area of the control grid and focusing the electrons into a beam. Its function of attracting electrons from the area of the grid is similar to the action of the plate in a conventional tube. The focusing action of the anode is similar to that performed by beam-forming plates in the beam-forming tetrode. Bear in mind, though, that beam-forming plates are negatively charged and repel electrons into electron sheets, while the focusing anode is positively charged and attracts electrons into beam.
5. The Accelerating Anode - in the CRT, this anode is used to accelerate the electrons toward the front of the tube. Its action is similar to the screen grid of tetrodes and pentodes. But remember, while the screen grid in conventional tubes accelerates electrons toward the plate, its primary purpose is to reduce interelectrode capacitance, NOT accelerate electrons.
6. The Vertical - Deflection Plates - in the CRT, these plates move the electron beam up and down the screen. The input signal is usually applied to these plates. While no equivalent element is found in conventional tubes, the principle employed (electrostatic attraction and repulsion) forms the heart of all vacuum tube operation.
7. The Horizontal-Deflection Plates - in the CRT, these plates move the electron beam by electrostatic attraction and repulsion, horizontally across the CRT screen. In most equipment using the CRT, including television sets, electronic signals are supplied to these plates to trace or paint a horizontal line.
8. The Aquadag Coating - in the CRT, this coating performs the same function as the suppressor grid in conventional tubes; namely, eliminating the effects of secondary emission. In conventional tubes, the suppressor grid is negatively charged and repels secondary emission electrons back to the plate. In the CRT, the aquadag is positively charged and attracts secondary emission away from the screen.

NEETS MODULE 6-Electronic Emission, Tubes, and Power Supplies
UNCLASSIFIED

9. The Screen - also called the face, is a unique element of the CRT. When struck by electrons, the phosphor coating becomes luminous, or glows, thus enabling the tube to visually present electronic signals.

From this comparison of the CRT and other types of electron tubes, one fact should be clear. Almost all tubes, no matter what their function, operate on two principles: electrostatic attraction and repulsion, and thermionic emission. By keeping these two principles in mind, you should be able to analyze any type of tube operation.

Q14. What is the unique ability of the CRT?

Q15. What are the three main parts of CRT?

Q16. What term is used for the ability of a spot on a CRT screen to continue to glow after the electron beam has struck it and moved away?

Q17. The electron beam in a CRT is made to sweep from left to right across the screen. What tube element causes this sweeping motion?

Q18. In applications where electronic waveforms are displayed on a CRT screen, the input signal is normally applied to what CRT element?

NEETS MODULE 6-Electronic Emission, Tubes, and Power Supplies

UNCLASSIFIED

2.9 SAFETY

There are certain safety precautions you should follow when you work with or handle the special tubes covered in this chapter. We will examine these tubes and their associated precautions in the following sections.

2.9.1 Electron Tubes

The average electron tube is a rugged device capable of withstanding the shocks and knocks of everyday usage and handling. However, they are not indestructible. You should remember that most electron tubes contain a near vacuum enclosed by a glass envelope. Because of this, the glass is under constant stress from atmospheric pressure. Any undue stress, such as striking the envelope against a hard surface, may cause the envelope to shatter, resulting in an **IMPLOSION**.

An implosion is just the opposite of an explosion. When the glass envelope of an electron tube shatters, the outside atmosphere rushes into the tube to fill the vacuum. As the air rushes into the tube, it carries glass fragments of the envelope with it. Once these fragments reach the center of the tube, they continue outward with considerable velocity. The result is similar to an explosion, in that the immediate area surrounding the electron tube is filled with fast-moving glass fragments. You, as a nearby object, may find yourself the target for many of these glass fragments. For this reason you should handle all electron tubes with care.

2.9.2 Cathode-Ray Tubes (CRTS)

Since most electron tubes are small, the possibility of them being a safety hazard is usually very small. There are two exceptions to this: CRT's and radioactive tubes.

The glass envelope of a CRT encloses a high vacuum. Because of its large volume and surface area, the force exerted on a CRT by atmospheric pressure is considerable. The total force on a 10-inch CRT may exceed 4,000 pounds. Over 1000 pounds is exerted on the CRT face alone.

NEETS MODULE 6-Electronic Emission, Tubes, and Power Supplies

UNCLASSIFIED

When a CRT is broken, a large implosion usually occurs. Almost two tons of force hurl glass fragments toward the center of the tube. At the same time, the electron gun is normally thrown forward inside the tube. The face, because of its size, tends to move very slowly toward the center of the tube. This presents one of the main hazards of a broken CRT. The electron gun passes through the center of the tube with considerable force. It continues until it strikes the CRT face. The impact from the electron gun normally breaks the CRT face into many small fragments, which are hurled outward. The face is coated with a chemical coating that is extremely toxic. If you are unfortunate enough to experience an accidental implosion of a CRT and are nicked by one of these fragments, seek immediate medical aid. As you can see, improper handling of a CRT can be very hazardous to your health.

The CRT is, in essence, a tiny fragmentation bomb. The major difference between a CRT and a bomb is that a bomb is designed to explode; a CRT is not. As long as you handle a CRT properly, it represents no danger to you. Only when you mishandle it do you risk the danger of being pelted with an electron gun and toxic glass fragments. When handling a CRT, you should take the following precautions:

1. Avoid scratching or striking the surface of the CRT.
2. Do not use excessive force when you remove or replace a CRT's deflection yoke or socket.
3. Do not try to remove an electromagnetic-type CRT from its yoke until you have discharged the high voltage from the CRT's anode connector (hole).
4. Never hold the CRT by its neck.
5. Always set the CRT with its face down on a thick piece of felt, rubber, or smooth cloth.
6. Always handle the CRT gently. Rough handling or a sharp blow on the service bench can displace the electrodes within the tube, causing faulty operation.
7. Wear safety glasses and protective gloves.

One additional handling procedure you should be aware of is how to dispose of a CRT properly. When you replace a CRT, you cannot simply throw the old CRT over the side of the ship, or place it in the nearest dumpster. When thrown over the side of a ship, a CRT will float; if it washes ashore, it is dangerous to persons who may come in contact with it. A CRT thrown in a dumpster represents a hidden booby trap. Therefore, always render the CRT harmless before you dispose of it. This is a fairly simple procedure, as outlined below.

Note: Be sure to wear safety goggles.

NEETS MODULE 6-Electronic Emission, Tubes, and Power Supplies UNCLASSIFIED

- Place the CRT face down in an empty carton and cover its side and back with protective material.
- Carefully break off the plastic locating pin from the base (fig. 2-29) by crushing the locating pin with a pair of pliers.

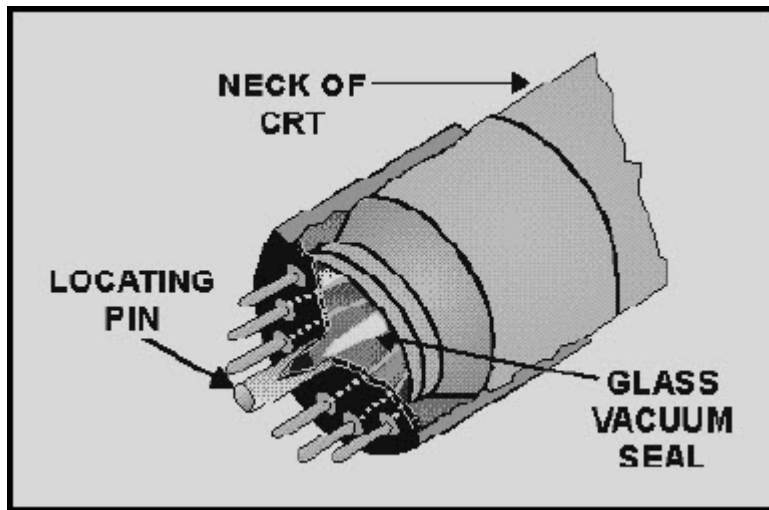

Figure 2-29 Cathode-ray tube base structure

- Brush the broken plastic from the pin off the CRT base.
- Look into the hole in the base where the locator pin was. You will see the glass extension of the CRT called the vacuum seal. Grasp the vacuum seal near the end with the pliers and crush it.

This may sound a little risky but it isn't. The vacuum seal can be crushed without shattering the tube. Once the seal has been crushed, air will rush into the tube and eliminate the vacuum.

NEETS MODULE 6-Electronic Emission, Tubes, and Power Supplies

UNCLASSIFIED

2.9.3 Radioactive Electron Tubes

Another type of tube that can prove hazardous to you, if you handle it improperly, is the radioactive tube.

These tubes contain radioactive material and are used as voltage-regulator, gas-switching, and cold-cathode, gas-rectifier tubes. Some of these tubes have dangerous radioactive intensity levels. Radioactive tubes are marked according to military specifications.

Radioactive material is added to a tube to aid in ionization. The radioactive material emits relatively slowly moving particles. This should not worry you because the glass envelope is thick enough to keep these particles inside the tube. Therefore, proper handling is nothing more than ensuring that the envelope remains unbroken. If these tubes are broken and the radioactive material is exposed, or escapes from the confines of the electron tube, the radioactive material becomes a potential hazard.

The concentration of radioactivity in an average collection of electron tubes in a maintenance shop does not approach a dangerous level, and the hazards of injury from exposure are slight. However, at major supply points, the storage of large quantities of radioactive electron tubes in a relatively small area may create a hazard. For this reason, personnel working with equipment using electron tubes containing radioactive material, or in areas where a large quantity of radioactive tubes are stored, should read and become thoroughly familiar with the safety practices contained in *Radiation, Health, and Protection Manual*, NAVMED P-5055. Strict compliance with the prescribed safety precautions and procedures of this manual will help to prevent accidents, and to maintain a safe working environment which is conducive to good health.

The clean-up procedures listed below are based on NAVMED P-5055. Your ship or station may have additional procedures that you should follow. Be sure you are aware of your command's policy concerning decontamination procedures before you begin working on equipment containing radioactive tubes. Some important instructions and precautions for the proper handling of radioactive tubes are listed below:

NEETS MODULE 6-Electronic Emission, Tubes, and Power Supplies
UNCLASSIFIED

1. Do not remove radioactive tubes from their carton until you are ready to install them.
2. When you remove a tube containing a radioactive material from equipment, place it immediately in an appropriate carton to prevent possible breakage.
3. Never carry a radioactive tube in a manner that may cause it to break.
4. If a radioactive tube that you are handling or removing breaks, notify the proper authority and obtain the services of qualified radiological personnel immediately.
5. Isolate the immediate area of exposure to protect other personnel from possible contamination and exposure.
6. Follow the established procedures set forth in NAVMED P-5055.
7. Do not permit contaminated material to come in contact with any part of your body.
8. Take care to avoid breathing any vapor or dust that may be released by tube breakage.
9. Wear rubber or plastic gloves at all times during cleanup and decontamination procedures.
10. Use forceps to remove large fragments of a broken radioactive tube. Remove the remaining small particles with a designated vacuum cleaner, using an approved disposal collection bag. If a vacuum cleaner is not designated, use a wet cloth to wipe the affected area. In this case, be sure to make one stroke at a time. **DO NOT** use a back-and-forth motion. After each stroke, fold the cloth in half, always holding one clean side and using the other for the new stroke. Dispose of the cloth in the manner stated in instruction 14 below.
11. Do not bring food or drink into the contaminated area or near any radioactive material.
12. Immediately after leaving a contaminated area, if you handled radioactive material in any way, remove all of your clothing. Also wash your hands and arms thoroughly with soap and water, and rinse with clean water.
13. Notify a medical officer immediately if you sustain a wound from a sharp radioactive object. If a medical officer cannot reach the scene immediately, stimulated mild bleeding by applying pressure about the wound and by using suction bulbs. **DO NOT USE YOUR MOUTH** if the wound is a puncture-type wound. If the opening is small, make an incision to promote free bleeding, and to make the wound easier to clean and flush.

NEETS MODULE 6-Electronic Emission, Tubes, and Power Supplies

UNCLASSIFIED

14. When you clean a contaminated area, seal all debris, cleaning cloths, and collection bags in a container such as a plastic bag, heavy wax paper, or glass jar, and place them in a steel can until they can be disposed of according to existing instructions.

15. Use soap and water to decontaminate all tools and implements you used to remove the radioactive substance. Monitor the tools and implements for radiation with an authorized radiac set to ensure that they are not contaminated.

As you can see, the cleanup that results from breaking a radioactive tube is a long and complicated procedure. You can avoid this by simply ensuring that you don't break the tube.

2.9.4 Conventional Tubes

While conventional tubes present few safety problems, beyond broken glass and the possibility of cutting yourself, there is one precaution you must know. Namely, electron tubes are hot. The filaments of some tubes may operate at several thousand degrees. As a result, the envelopes can become very hot. When you work on electron tube equipment, always deenergize the equipment and allow the tubes sufficient time to cool before you remove them. If this is impossible, use special tube pullers which the Navy stocks for this purpose. Never attempt to remove a hot tube from its socket with your bare fingers.

NEETS MODULE 6-Electronic Emission, Tubes, and Power Supplies

UNCLASSIFIED

2.10 SUMMARY

The following summary covers the main points of this chapter. Study it to be sure you understand the material before you begin the next chapter.

MULTI-UNIT TUBES were developed to reduce the size of vacuum tube circuits. Incorporating more than one tube in the same envelope allowed the size of a vacuum tube circuit to be reduced considerably. While a single envelope may contain two or more tubes, these tubes are independent of each other.

MULTI-ELECTRODE TUBES were developed to extend the capability of conventional tubes. In some cases, a multi-element tube may contain up to seven grids. These types of tubes are normally classified by the number of grids they contain.

POWER PENTODES are used as current or power amplifiers. Power pentodes use in-line grid arrangements. In this manner, more electrons can reach the plate from the cathode. In effect, this lowers plate resistance and allows maximum conduction through the tube.

BEAM-POWER TUBES are also used as power amplifiers. In addition to the in-line grid arrangement, beam-power tubes use a set of negatively charged beam-forming plates. The beam-forming plates force electrons that would normally be deflected from the plate back into the electron stream and, thus, add to the number of electrons the tube can use for power amplification.

VARIABLE-MU (μ) TUBES or REMOTE-CUTOFF TUBES were developed to extend the amplification range of electron tubes by avoiding the possibility of driving the tube into cutoff. This is done by uneven spacing of the grid wires.

UHF TUBES are special-purpose tubes designed to operate at ultrahigh frequencies between 300 MHz and 3000 MHz with minimum effect from transit time limitations. Among these are acorn tubes, and doorknob tubes, lighthouse tubes, and oilcan tubes.

PLANAR TUBES have their plates and grids mounted parallel to each other. Because of their planar construction, they can handle large amounts of power at uhf frequencies.

GAS-FILLED TUBES contain a small amount of gas that ionizes and reduces the internal resistance of the tubes. Because of this, gas-filled tubes can handle relatively large amounts of power while maintaining a constant voltage drop across the tube.

NEETS MODULE 6-Electronic Emission, Tubes, and Power Supplies

UNCLASSIFIED

COLD-CATHODE TUBES lack heaters or filaments and, therefore, do not use thermionic emission. Instead, a voltage potential applied across the tube causes the internal gas to ionize. Once ionization has occurred, the voltage drop across the tube remains constant, regardless of increased conduction.

The **CRT** is a special-purpose tube that has the unique ability to visually display electronic signals. The CRT uses the principles of electrostatic attraction, repulsion, and fluorescence. Because of its unique ability, the CRT makes up the heart of many types of test equipment that you will become familiar with during your career in electronics.

NEETS MODULE 6-Electronic Emission, Tubes, and Power Supplies
UNCLASSIFIED

ANSWERS TO QUESTIONS Q1. THROUGH Q18.

- A1. Conventional pentodes have a staggered grid arrangement, while power pentodes have a shielded grid arrangement.*
- A2. Beam-forming plates.*
- A3. By increasing the number of electrons that reach the plate, plate current is increased.*
- A4. A large negative voltage causes conduction to occur only at the center of the grid*
- A5. Decreases gain.*
- a. Power pentode or beam-forming tetrode.*
 - b. Conventional tube.*
 - c. Variable-mu tube.*
- A6. It causes the control grid to short to the cathode.*
- A7. By reducing the spacing between tube elements.*
- A8. The close spacing of tube elements allows for the ready formation of arcs or short circuits.*
- A9. Planar*
- A10.*
- a. They can carry more current.*
 - b. They maintain a constant IR drop across the tube.*
- A11. None.*
- A12. The filament's voltage should be applied to the tube at least 30 seconds before attempting to operate the tube.*
- A13. They have the ability to maintain a constant voltage drop across the tube despite changes in current flow.*
- A14. To visually display electronic signals.*

NEETS MODULE 6-Electronic Emission, Tubes, and Power Supplies
UNCLASSIFIED

A15.

a. Electron gun.

b. Deflection system

c. Screen.

A16. Persistence.

A17. The horizontal-deflection plate.

A18. The vertical-deflection plate.

NEETS MODULE 6-Electronic Emission, Tubes, and Power Supplies

UNCLASSIFIED

3 POWER SUPPLIES

LEARNING OBJECTIVES

Upon completion of this chapter, you will be able to:

1. Identify the various sections of a power supply.
2. State the purpose of each section of a power supply.
3. Describe the operation of the power supply from both the whole unit standpoint and from the subunit standpoint.
4. Describe the purpose of the various types of rectifier circuits used in power supplies.
5. Describe the purpose of the various types of filter circuits used in power supplies.
6. Describe the operation of the various voltage and current regulators in a power supply.
7. Trace the flow of ac and dc in a power supply, from the ac input to the dc output on a schematic diagram.
8. Identify faulty components through visual checks.
9. Identify problems within specific areas of a power supply by using a logical isolation method of troubleshooting.
10. Apply safety precautions when working with electronic power supplies.

3.1 INTRODUCTION

In the early part of this century when electronics was first introduced, most electronic equipment was powered by batteries. While the use of batteries allowed the equipment to be portable (to some degree), it also placed several limitations on how the equipment could be used. Because of their general inefficiency, batteries had to be either replaced frequently or, if they were rechargeable, kept near a battery charger. Thus, the advantage of having portable equipment was more than offset by the need to replace or recharge the batteries frequently.

Users of electronic equipment needed a power supply that was reliable, convenient, and cost effective. Since batteries failed to satisfy these requirements, the "electronic power supply" was developed.

In today's Navy, all electronic equipment, both ashore and on board ship, require some type of power supply. Therefore, this chapter is of extreme importance to you. We will discuss the sections and individual components of the power supply and their purposes within the power supply. We will also discuss troubleshooting of each section and its components.

NEETS MODULE 6-Electronic Emission, Tubes, and Power Supplies

UNCLASSIFIED

3.2 THE BASIC POWER SUPPLY

Figure 3-1 shows the block diagram of the basic power supply. Most power supplies are made up of four basic sections: a **TRANSFORMER**, a **RECTIFIER**, a **FILTER**, and a **REGULATOR**.

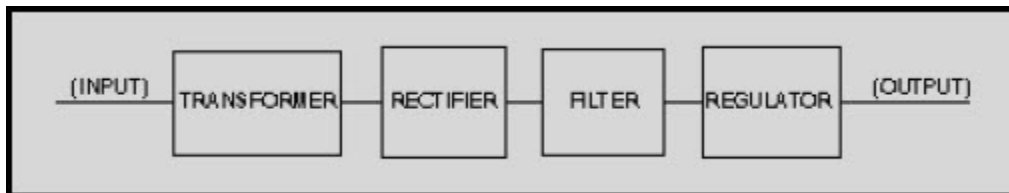

Figure 3-1 Block diagram of a basic power supply

As you can see, the first section is the **TRANSFORMER**. The transformer serves two primary purposes: (1) to step up or step down the input line voltage to the desired level and (2) to couple this voltage to the rectifier section. The **RECTIFIER** section converts the ac signal to a pulsating dc voltage. However, you will see later in this chapter that the pulsating dc voltage is not desirable. For this reason, a **FILTER** section is used to convert the pulsating dc voltage to filtered dc voltage. The final section, the **REGULATOR**, does just what the name implies. It maintains the output of the power supply at a constant level in spite of large changes in load current or in input line voltage. Depending upon the design of the equipment, the output of the regulator will maintain a constant dc voltage within certain limits.

Now that you know what each section does, let's trace a signal through the power supply and see what changes are made to the input signal. In figure 3-2, the input signal of 120 volts ac is applied to the primary of the transformer, which has a turns ratio of 1:3. We can calculate the output by multiplying the input voltage by the ratio of turns in the secondary winding to turns in the primary winding. Therefore, the output voltage of our example is: 120 volts ac \times 3, or 360 volts ac. Depending on the type of rectifier used (full-wave or half-wave), the output from the rectifier will be a portion of the input.

NEETS MODULE 6-Electronic Emission, Tubes, and Power Supplies UNCLASSIFIED

Figure 3-2 shows the ripple waveform associated with a full-wave rectifier. The filter section contains a network of resistors, capacitors, or inductors that controls the rise and fall time of the varying signal so that the signal remains at a more constant dc level. You will see this more clearly in the discussion of the actual filter circuits. You can see that the output of the filter is at a 180-volt dc level with an ac **RIPPLE** voltage riding on it. (Ripple voltage is a small ac voltage riding at some dc voltage level. Normally, ripple voltage is an unwanted ac voltage created by the filter section of a power supply.) This signal now goes to the regulator where it will be maintained at approximately 180 volts dc to the load.

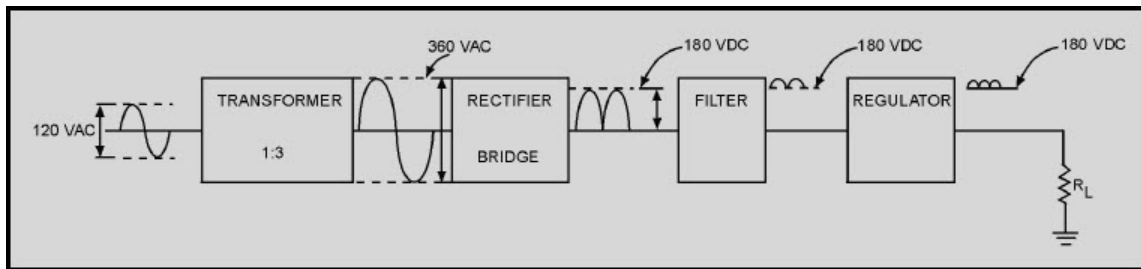

Figure 3-2 Block diagram of a power supply

Q1. What are the four basic sections to a power supply?

Q2. What is the purpose of the regulator?

NEETS MODULE 6-Electronic Emission, Tubes, and Power Supplies

UNCLASSIFIED

3.2.1 The Transformer

The transformer has several purposes: In addition to coupling the input ac signal to the power supply, it also isolates the electronic power supply from the external power source and either steps up or steps down the ac voltage to the desired level. Additionally, most input transformers have separate step-down windings to supply filament voltages to both power supply tubes and the tubes in the external equipment (load). Such a transformer is shown in figure 3-3. Because the input transformer is located in the power supply and is the ultimate source of power for both the load and the power supply, it is called the **POWER TRANSFORMER**. Notice that the transformer has the ability to deliver both 6.3 and 5 volts ac filament voltages to the electron tubes. The High-voltage winding is a 1:3 step-up winding and delivers 360 volts ac to the rectifier. This transformer also has what is called a *center tap*. This center tap provides the capability of developing two high-voltage outputs from one transformer.

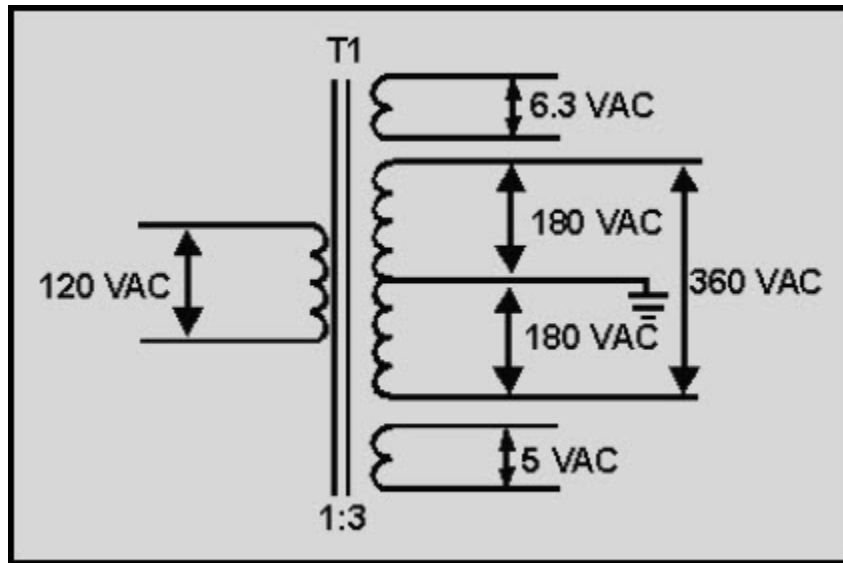

Figure 3-3 Typical power transformer

Q3. What are the purposes of the transformer in a power supply?

Q4. For what are the low voltage windings in a transformer used?

Q5. For what is the center tap on a transformer used?

NEETS MODULE 6-Electronic Emission, Tubes, and Power Supplies UNCLASSIFIED

3.2.2 Rectifiers

From previous discussions, you know that rectification is the changing of an ac voltage to a pulsating dc voltage. Now let's discuss the process of rectification.

Since a diode vacuum tube will pass current in only one direction, it is ideally suited for converting alternating current to direct current. If an ac voltage is applied to a diode, the diode will conduct **ONLY DURING THE POSITIVE ALTERNATION OF VOLTAGE** when the plate of the diode is made positive with respect to the cathode.

Figure 3-4 shows a diode connected across the 120-volt ac line. During the positive alternation of the source voltage, the sine wave applied to the tube makes the plate positive with respect to the cathode. At this time the diode conducts and plate current flows from the negative supply lead, through the milliammeter, through the tube, and to the positive supply lead. This is indicated by the shaded area of the output waveform. This current exists during the entire period of time that the plate is positive with respect to the cathode (for the first 180 degrees of the input sine wave).

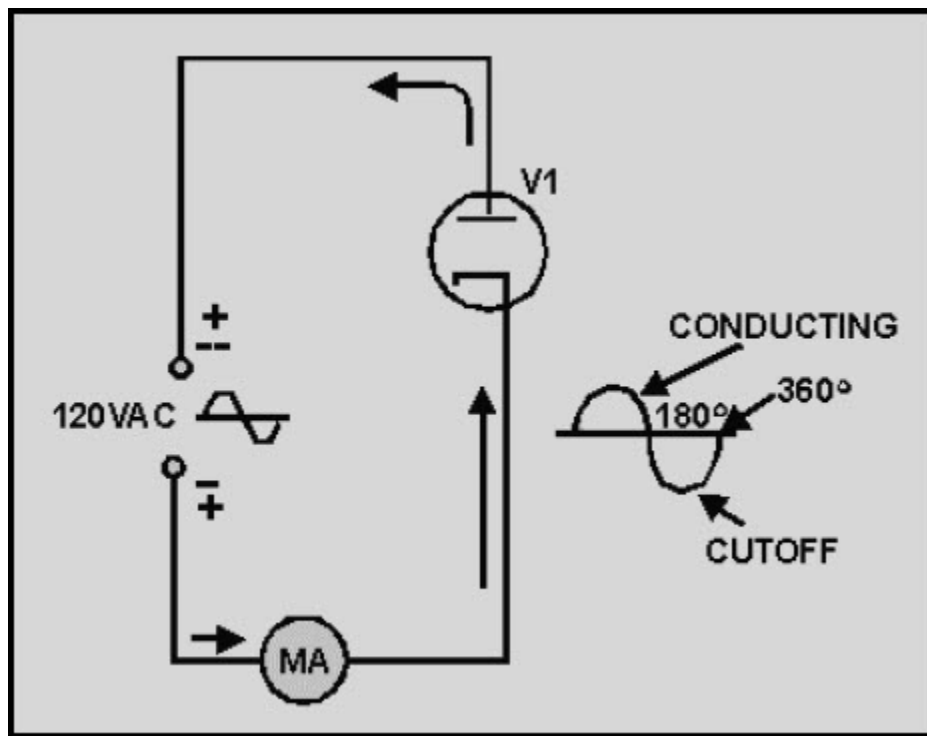

Figure 3-4 Simple diode rectifier

NEETS MODULE 6-Electronic Emission, Tubes, and Power Supplies UNCLASSIFIED

During the negative alternation of plate voltage (dotted polarity signs), the plate is driven negative and the tube cannot conduct. When conditions prevent the tube from conducting, the tube is said to be in **CUTOFF**. This is indicated by the dotted waveform. The tube will be in cutoff and no current will flow for the entire negative alternation.

For each 360-degree cycle of input voltage, the tube conducts for 180 degrees and is in cutoff for 180 degrees. The circuit current therefore has the appearance of a series of positive pulses, as shown by the shaded areas. Notice that although the current is in the form of pulses, the current always flows through the circuit in **THE SAME DIRECTION**. Current that flows in pulses in the same direction is called **PULSATING DC**. The diode has thus **RECTIFIED** the input voltage. Although the principle of rectification applies to all rectifier circuits, some rectifiers are more efficient than others. For this reason, we will explain the three rectifier circuits most commonly used in electronics today-the half-wave, full-wave, and bridge.

NEETS MODULE 6-Electronic Emission, Tubes, and Power Supplies

UNCLASSIFIED

3.2.2.1 A Practical Half-Wave Rectifier

Figure 3-5 is a diagram of a complete half-wave rectifier circuit. For the diode to be used as a rectifier, it must be connected in series with a load device (R_L for this circuit), through which the direct current flows. Because Navy electronic equipment requires various input voltages, it is necessary to have a rectified voltage that is greater (or smaller in some cases) than the source voltage. The rectifier plate circuit is supplied power from a step-up (or step-down) transformer. Notice that the transformer has the two secondary windings mentioned earlier. The lower winding supplies high voltage to the plate and cathode of the diode, and the upper winding supplies a low ac voltage to the filaments of the diode. Notice also that the cathode of the diode is connected to the secondary winding of the transformer through the load resistor (R_L). Any current flowing through the tube also flows through the load resistor, causing a voltage to be developed across it. The magnitude of the voltage developed across the load resistor is directly proportional to the amount of current flowing through it (Ohm's law: $E = IR$).

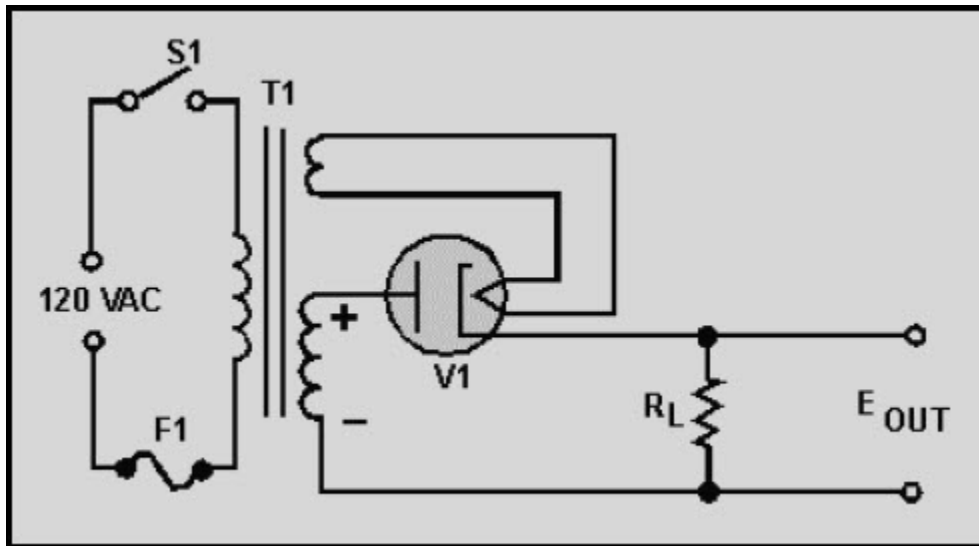

Figure 3-5 Half-wave rectifier circuit

NEETS MODULE 6-Electronic Emission, Tubes, and Power Supplies UNCLASSIFIED

You will better understand the operation of the half-wave rectifier circuit if it is redrawn in the form of a simplified series circuit. As you can see in figure 3-6, the diode (V1) and load resistor (R_L) are in series with the secondary winding of the transformer. During the positive alternation of the input, as the voltage in the secondary winding increases, the current through diode (V1) and load resistor (R_L) increases. Since the diode tube and the load resistor form a series circuit, the same current flows through both the tube and the resistor. This current produces a voltage drop across the tube and the load resistor, which have polarities as shown. Since the plate resistance of the tube is only about 500 ohms and the resistance of the load resistor is 10,000 ohms, approximately 95 percent of the applied 425 volts is dropped across the load resistor ($425 \times .95 = 404$ V) and 5 percent ($425 \times .05 = 21$ V) across the tube.

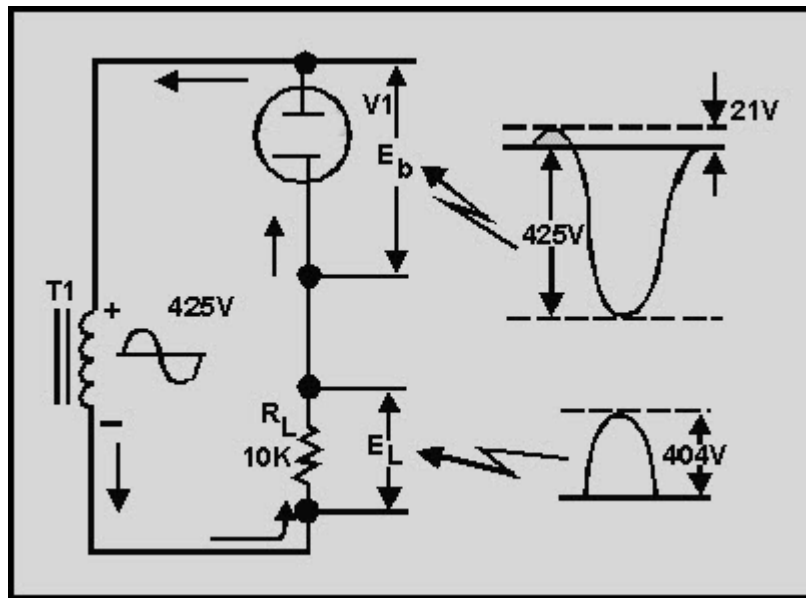

Figure 3-6 Simplified half-wave rectifier circuit and waveforms

During the negative half of the alternation of input voltage, the tube cannot conduct and no current flows in the circuit. Since there is no current flow through R_L , the load voltage remains at zero volts throughout the negative alternation. During this time the entire negative alternation is felt across the tube. The reason for this is derived from Kirchoff's law, which states:

$$E_L + E_b = E_a$$

The sum of the load voltage and diode voltage equals the applied voltage.

NEETS MODULE 6-Electronic Emission, Tubes, and Power Supplies UNCLASSIFIED

Since a half-wave rectifier conducts once for each full cycle of input voltage, the frequency of the pulses is the same as the frequency of the input sine wave. The output pulse frequency is called **RIPPLE FREQUENCY**. If the rectifier circuit is supplied power from a 60-hertz ac line voltage, 60 pulses of load current will occur each second. Therefore, **THE RIPPLE FREQUENCY OF A HALF-WAVE RECTIFIER IS THE SAME AS THE LINE FREQUENCY**.

If a series of current pulses like those obtained from a half-wave rectifier is applied to a load resistance, an average amount of power will be dissipated over a given period of time. This average dc power is determined by the amplitude of the pulses and the time delay between pulses. The higher the peak amplitude of the pulses or the less the time between pulses, the greater the average dc power supplied to the load. To determine average dc voltage (E_{avg}), it is necessary to know the average value of the pulses and the peak value of load voltage. This is illustrated in figure 3-7.

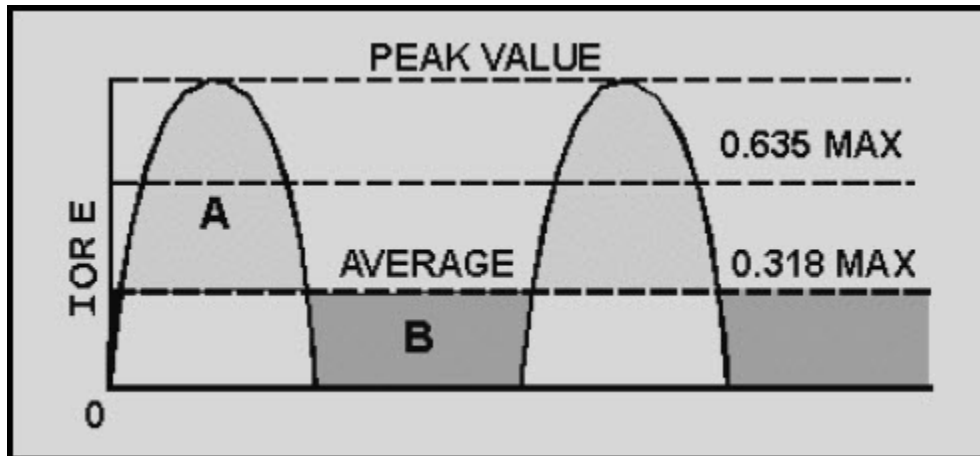

Figure 3-7 Peak and average values for a half-wave rectifier

NEETS MODULE 6-Electronic Emission, Tubes, and Power Supplies

UNCLASSIFIED

Since current and voltage waveforms in a half-wave rectifier circuit are essentially half sine waves, we can develop a conversion factor. The formula for average value was discussed earlier in *NEETS*, module 2. By now you should know that the average value for a full sine wave is .637 times its peak or maximum value. Therefore, if you want the average value of a half-wave rectifier output, you should multiply half the value of .637 (.318) times the peak or maximum voltage, as expressed in the following equation:

$$E_{\text{avg}} \text{ (the average load voltage)} = .318 \times E_{\text{max}}$$

Where:

E_{max} = The peak value of the load voltage pulse

In most applications the drop across the rectifier tube is small compared to the load voltage, so we can assume E_{max} in our equation to be the same as the peak value of the input sine wave.

Since the load current has the same wave shape as the load voltage, we can modify the equation so that it applies to the load current. Thus,

$$I_{\text{avg}} \text{ (the average load current)} = .318 \times I_{\text{max}}$$

Where:

I_{max} = The peak load current

If a line is drawn through the rectified waveform at a point that is 0.318 of the distance from zero to maximum, the waveform will be divided so that area A is equal to area B (fig. 3-7). Therefore, current or voltage pulses with a value of .318 of the peak value have the same effect on the load as a steady voltage or current.

The half-wave rectifier uses the transformer during only one-half of the cycle. Therefore, for any given size transformer, less power is developed than if the transformer were used on both halves of the cycle. In other words, to obtain large amounts of power, the half-wave transformer must be relatively large in comparison to what it would have to be if both halves of the cycle were used. This disadvantage limits the use of the half-wave rectifier to applications that require a very small current drain. The half-wave rectifier is widely used for commercial ac and dc radio receivers and other applications where inexpensive voltage supplies will suffice. As you can see from your study on half-wave rectifiers, this type of circuit placed many limitations on electronic equipment. For this reason another type of rectifier circuit had to be developed. One of the factors that had to be considered was how to use the full output from the transformer to obtain the highest average voltage and current. Thus, the **FULL-WAVE** rectifier was developed.

NEETS MODULE 6-Electronic Emission, Tubes, and Power Supplies
UNCLASSIFIED

Q6. Does a rectifier tube conduct on the positive or negative alternation of the input signal?

Q7. What term is used to describe the period when the diode is not conducting?

Q8. Current that flows in pulses in the same direction is called _____.

Q9. For a diode to act as a rectifier, should it be connected in series or parallel with the load?

Q10. What is the Ripple frequency of a half-wave rectifier if the input frequency is 60 Hz?

Q11. What is the equation for determining average voltage in a half-wave rectifier?

NEETS MODULE 6-Electronic Emission, Tubes, and Power Supplies

UNCLASSIFIED

3.2.2.2 The Conventional Full-Wave Rectifier

A full-wave rectifier is a device that has two or more diodes arranged so the load current flows in the same direction during each half cycle of the ac supply.

A schematic diagram of a simple full-wave rectifier is shown in figure 3-8. The transformer supplies the source voltage for two rectifier tubes (V1 and V2). This power transformer has a **CENTER-TAPPED** high-voltage secondary winding that is divided into two equal parts (W1 and W2). W1 provides the source voltage for V1 and the other winding (W2) provides the source voltage for V2. The connections to the diodes are arranged so that the diodes conduct on alternate half cycles.

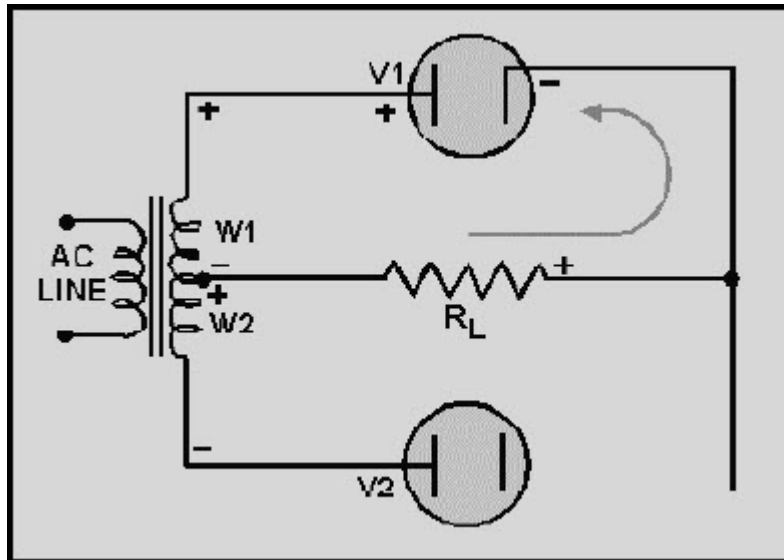

Figure 3-8 Simple full-wave rectifier (first alternation)

During one alternation of the secondary voltage, the polarities will be as shown in figure 3-8. The source for diode V2 is the voltage induced into the lower half of the transformer secondary winding (W2). At the specific instant of time shown in the figure, the plate voltage on V2 is negative, and V2 cannot conduct.

Throughout the period of time during which the plate of V2 is negative, the plate of V1 is positive. This is illustrated by the polarity signs across W1, which indicate the source for V1. Since the plate of V1 is positive, it conducts, causing current to flow through the load resistor in the direction shown by the arrow.

NEETS MODULE 6-Electronic Emission, Tubes, and Power Supplies UNCLASSIFIED

Figure 3-9 shows the next half cycle of secondary voltage. As you can see, the polarities across W1 and W2 are reversed. During this alternation the plate of V1 is driven negative and V1 cannot conduct.

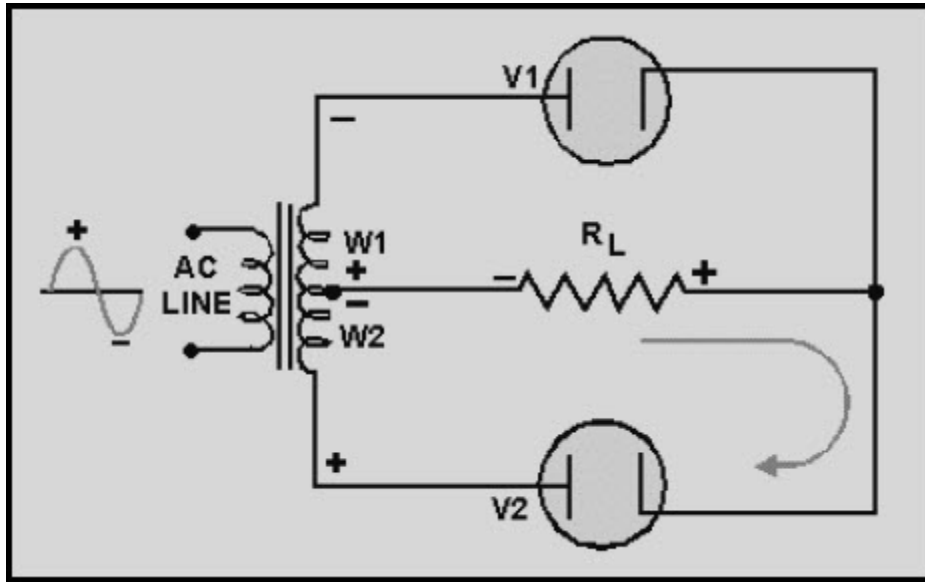

Figure 3-9 Simple full-wave rectifier (second alternation)

For the period of time that V1 is negative, the plate of V2 is positive, permitting V2 to conduct. Notice that the plate current of V2 passes through the load resistor in the same direction as did the plate current of V1. In this circuit arrangement, a pulse of load current flows during each alternation of the input cycle. Since both alternations of the input voltage cycle are used, the circuit is called a **FULL-WAVE RECTIFIER**.

Now that you have a basic understanding of how a full-wave rectifier works, let's cover in detail a practical full-wave rectifier and its waveforms.

NEETS MODULE 6-Electronic Emission, Tubes, and Power Supplies

UNCLASSIFIED

3.2.2.3 A Practical Full-Wave Rectifier

A practical full-wave rectifier circuit is shown in figure 3-10. It uses two diodes (V1 and V2) and a center-tapped transformer (T1). When the center tap is grounded, the voltages at the opposite ends of the secondary windings are 180 degrees out of phase with each other. Thus, when the voltage at point A is positive with respect to ground, the voltage at point B is negative with respect to ground. Let's examine the operation of the circuit during one complete cycle.

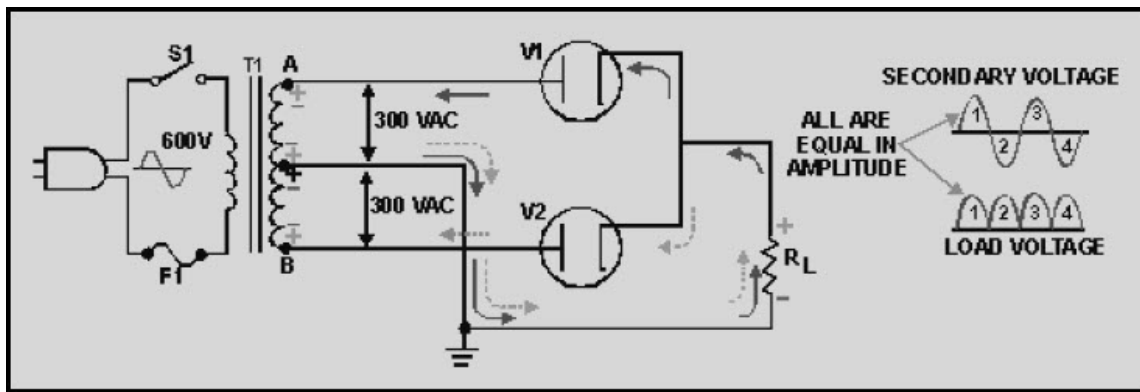

Figure 3-10 Complete full-wave rectifier

During the first half-cycle (as indicated by solid arrows) the plate of V1 is positive with respect to ground and the plate of V2 is negative. As shown, current flows from ground (center tap), up through the load resistor (R_L), and through diode V1 to point A. In the transformer, current flows from point A, through the upper winding and back to ground (center tap). When V1 conducts, it acts like a closed switch so that the positive half-cycle is felt across the load.

During the second half-cycle (broken lines), the polarity of the applied voltage has reversed. Now the plate of V2 is positive with respect to ground and the plate of V1 is negative. Only V2 can conduct. Current now flows, as shown, from ground (center tap), up through the load resistor (R_L), through diode V2 to point B of T1. In the transformer, current flows from point B up through the lower windings and back to ground (center tap). Notice that the current flows across the load resistor (R_L) in the **SAME DIRECTION** for both halves of the input cycles.

The output waveform from the full-wave rectifier consists of two pulses of current (or voltage) for each cycle of input voltage. The ripple frequency at the output of the full-wave rectifier is therefore **TWICE THE LINE FREQUENCY**.

NEETS MODULE 6-Electronic Emission, Tubes, and Power Supplies UNCLASSIFIED

The higher ripple frequency at the output of a full-wave rectifier has a distinct advantage: Because of the higher pulse frequency, the output is closely approximate to pure dc. This higher frequency also makes filtering much easier than the output of the half-wave rectifier.

In terms of peak value, the average value of current and voltage at the output of the full-wave rectifier is twice as great as the average current or voltage at the output of the half-wave rectifier. The relationship between peak and average values is illustrated in figure 3-11.

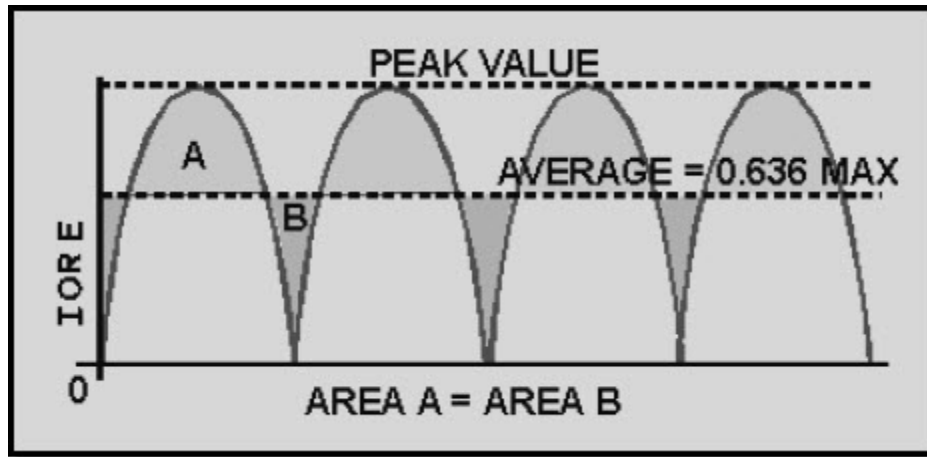

Figure 3-11 Peak and average values for a full-wave rectifier

Since the output waveform is essentially a sine wave with both alternations at the same polarity, the average current or voltage is 63.7 percent (or .637) of the peak current or voltage.

As an equation:

$$E_{\text{avg}} \text{ (the average load voltage)} = .637 \times E_{\text{max}}$$

Where

E_{max} = The peak value of the load voltage pulse

And

$$I_{\text{avg}} \text{ (the average load current)} = .637 \times I_{\text{max}}$$

Where:

I_{max} = The peak value of the load current pulse

NEETS MODULE 6-Electronic Emission, Tubes, and Power Supplies
UNCLASSIFIED

Example: The total voltage across the high-voltage secondary of a transformer used to supply a full-wave rectifier is 600 volts. Find the average load voltage. (Ignore the drop across the rectifier tube.)

Solution: Since the total secondary voltage is 600 volts, each diode is supplied one-half of this value, or 300 volts. As the secondary voltage is an rms value, the peak load voltage is:

$$E_{\max} = 1.414 \times E_S$$

$$E_{\max} = 1.414 \times 300$$

$$E_{\max} = 424 \text{ volts}$$

The average load voltage is:

$$E_{\text{avg}} = .637 \times E_{\max}$$

$$E_{\text{avg}} = .637 \times 424$$

$$E_{\text{avg}} = 270 \text{ volts}$$

NOTE: If you have problems with this equation, review NEETS, module 2, pertaining to this area.

As you may recall from your past studies in electricity, there are advantages and disadvantages in every circuit. The full-wave rectifier is no exception. In studying the full-wave rectifier, you have found that when the output frequency is doubled, the average voltage is also doubled, and the resulting signal is much easier to filter because of the high-ripple frequency. The only disadvantage is that the peak voltage in a full-wave rectifier is only half the peak voltage in a half-wave rectifier. This is because the secondary of the power transformer in a full-wave rectifier is center tapped; therefore only half the source voltage goes to each diode.

Fortunately, there is a rectifier that produces the same peak voltage as a half-wave rectifier and the same ripple frequency as a full-wave rectifier. This circuit, called the **BRIDGE RECTIFIER**, will be the chapter of our next discussion.

Q12. What is the ripple frequency of a full-wave rectifier with an input frequency of 60 Hz?

NEETS MODULE 6-Electronic Emission, Tubes, and Power Supplies
UNCLASSIFIED

Q13. What is the average voltage (E_{avg}) output of a full-wave rectifier that has an output of 100 volts peak?

3.2.2.4 The Bridge Rectifier

When four diodes are connected as shown in figure 3-12, the circuit is called a **BRIDGE RECTIFIER**. The input to the circuit is applied to the diagonally opposite corners of the network, and the output is taken from the remaining two corners.

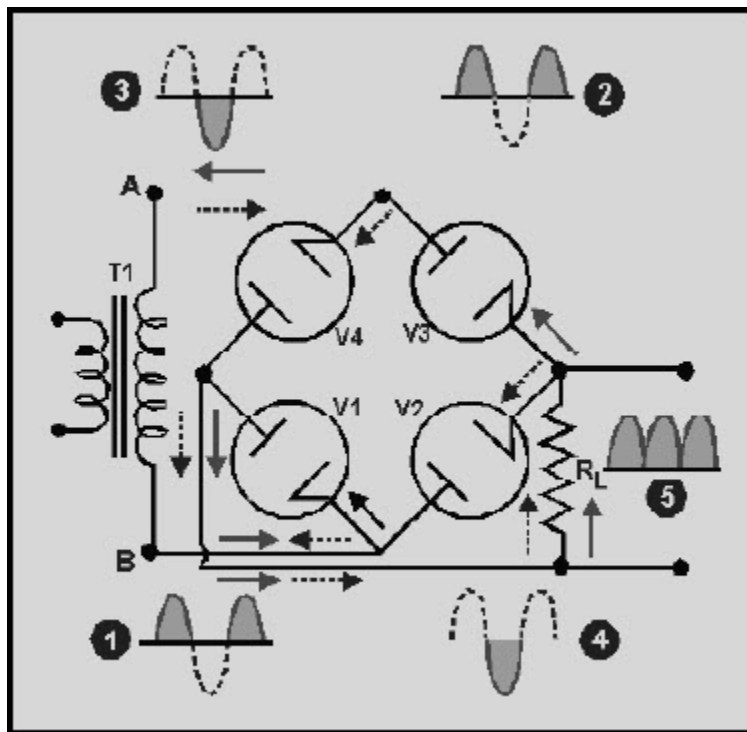

Figure 3-12 Bridge rectifier circuit

During one half-cycle of the applied voltage, point A becomes positive with respect to point B by the amount of voltage induced into the secondary of the transformer. During this time, the voltage between points A and B may be considered to be impressed across V1, the load resistor R_L, and V3, in series. The voltage applied across these tubes makes their plates more positive than their cathodes, and current flows from point B through tube V1 in an upward direction across the load resistor, through tube V3, to point A. This path is indicated by the solid arrows. The waveform is shown as numbers (1) and (2).

NEETS MODULE 6-Electronic Emission, Tubes, and Power Supplies
UNCLASSIFIED

One half-cycle later, the polarity across the secondary reverses, making the plates of V1 and V3 negative with respect to their cathodes. At the same time, the plates of V2 and V4 become positive with respect to their cathodes, and current flows in the direction indicated by the dashed arrows. The current through R_L is always in the same direction. This current, in flowing through R_L , develops a voltage corresponding to that shown in waveform (5) of the figure. The bridge rectifier is a full-wave rectifier since current flows through the load during both half cycles of the applied alternating voltage.

One advantage of a bridge rectifier over a conventional full-wave rectifier is that with a given transformer, the bridge rectifier produces a voltage output that is nearly twice that of the conventional full-wave circuit. We can show this by assigning values to some of the components as shown in figure 3-13, views (A) and (B).

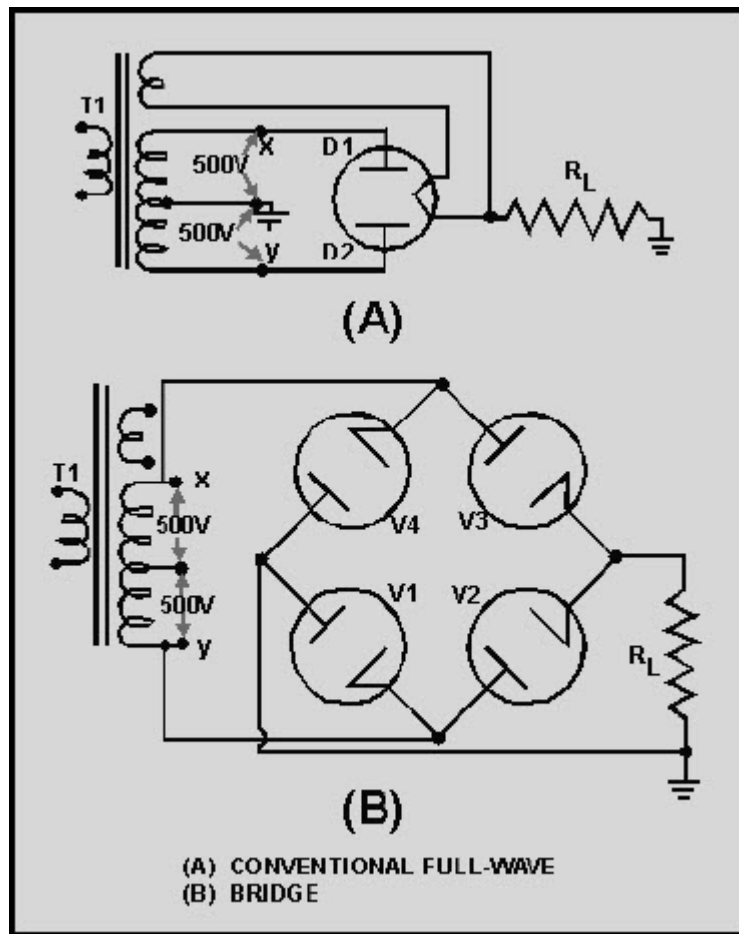

Figure 3-13 Comparison of conventional full-wave and bridge rectifiers: A. Conventional full-wave circuit

NEETS MODULE 6-Electronic Emission, Tubes, and Power Supplies UNCLASSIFIED

Assume that the same transformer is used in both circuits. The peak voltage developed between points X and Y is 1,000 volts in both circuits. In the conventional full-wave circuit, view (A), the peak voltage from the center tap to either X or Y is 500 volts. Since only one diode can conduct at any instant, the maximum voltage that can be rectified at any instant is 500 volts. Therefore, the maximum voltage that appears across the load resistor is nearly, but never exceeds, 500 volts (because of the small voltage drop across the tube). In the bridge rectifier of view (B), the maximum voltage that can be rectified is the full secondary voltage, 1,000 volts. Therefore, the peak output voltage across the load resistor is nearly 1,000 volts. Thus, with both circuits using the same transformer, the full-wave bridge circuit produces a higher output voltage than the conventional full-wave rectifier.

A second advantage of the bridge rectifier is the low ratio of peak inverse voltage to average output voltage. For this reason bridge rectifiers that use vacuum tubes are widely used in high-voltage power supply applications.

If directly heated diodes are used in a bridge rectifier, three separate filament transformers are required. This is due to the different potentials existing at the filaments of the diodes. The filaments of V2 and V3 in figure 3-14 are at the same potential, but the filament of V1 is at a different potential from either V2 or V4.

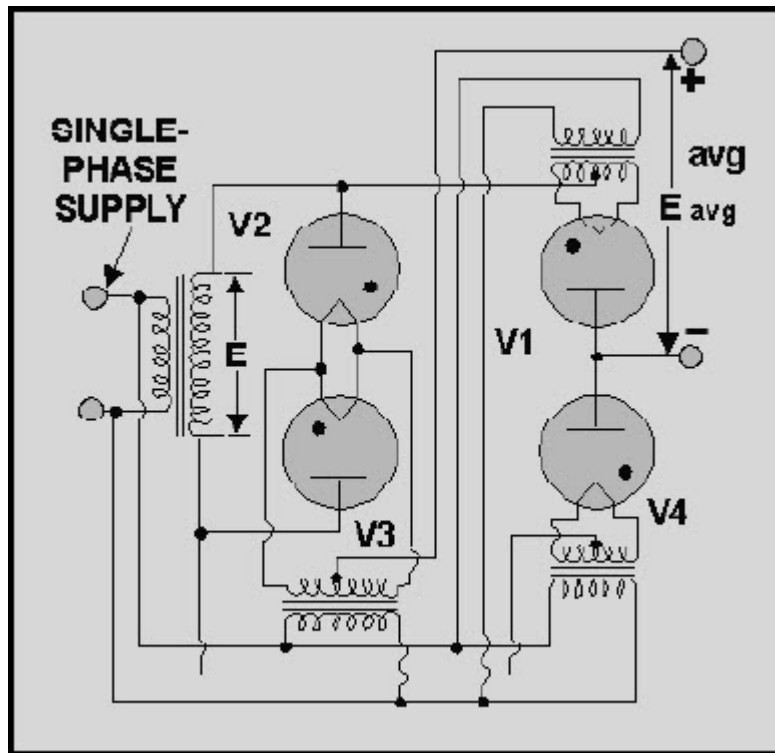

Figure 3-14 Bridge rectifier with filament transformers

NEETS MODULE 6-Electronic Emission, Tubes, and Power Supplies

UNCLASSIFIED

The three filament transformers must be well insulated from each other, and from ground, because of the high potentials to which they are subjected. The use of indirectly heated diodes would solve the filament transformer problem, but the high potential difference between cathode and heater would be likely to result in arcing.

Q14. What is the main disadvantage of the conventional full-wave rectifier?

Q15. What main advantage does a bridge rectifier have over a conventional full-wave rectifier?

3.2.3 Filters

While the output of a rectifier is a pulsating dc, most electronic circuits require a substantially pure dc for proper operation. This type of output may be provided by placing single or multi-section filter circuits between the output of the rectifier and the load.

There are four basic types of filter circuits:

- Simple capacitor filter
- LC choke-input filter
- LC capacitor-input filter (pi-type)
- RC capacitor-input filter (pi-type)

We will cover the function of each of these filters in detail later in this chapter.

Filtering is done by using various combinations of capacitors, inductors, and resistors. Inductors are used as series impedances to oppose the change in flow of alternating (pulsating dc) current. Capacitors are used as shunt elements to bypass the alternating components of the signal around the load (to ground). Resistors are used in place of inductors in low current applications.

Let's briefly review the properties of a capacitor. First, a capacitor opposes any change in voltage. The opposition to a change in voltage is called capacitive reactance (X_C) and is measured in ohms. The capacitive reactance is determined by the frequency (f) of the applied voltage and capacitance (C) of the capacitor.

NEETS MODULE 6-Electronic Emission, Tubes, and Power Supplies
UNCLASSIFIED

$$X_c = \frac{1}{2\pi fC} \text{ or } \frac{.159}{fC}$$

From the formula, you can see that if frequency or capacitance is increased, the X_c will decrease. Since filter capacitors are placed in parallel with the load, a low X_c will provide better filtering than a high X_c . This is done by providing a better shunting effect of the ac around the load, as shown in figure 3-15.

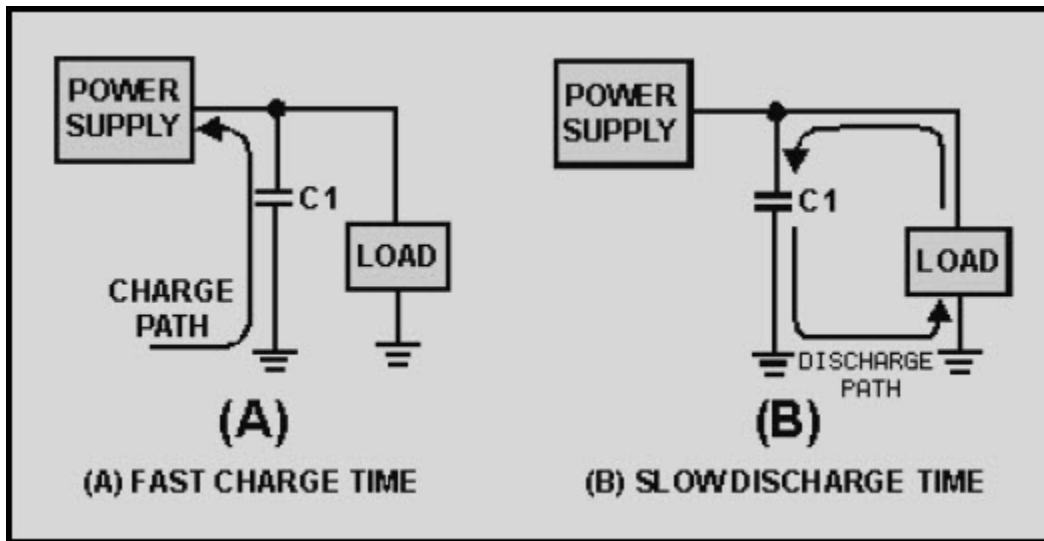

Figure 3-15 Capacitor filter. Fast charge time

To obtain a steady dc output, the capacitor must charge almost instantaneously to the value of applied voltage. Once charged, the capacitor must retain the charge as long as possible. The capacitor must have a short charge time constant (view A) and a long discharge time constant (view B). This can be done by keeping the internal resistance of the power supply as small as possible (fast charge time) and the resistance of the load as large as possible (slow discharge time).

NEETS MODULE 6-Electronic Emission, Tubes, and Power Supplies UNCLASSIFIED

From your earlier studies in basic electricity, you may remember that one capacitor time constant is defined as the time it takes a capacitor to charge to 63.2 percent of the applied voltage or to discharge to 36.8 percent of its total charge. This can be expressed by the following equation:

$$t = R \times C$$

Where: R represents the resistance of the charge or discharge path

And: C represents the capacitance of the capacitor

You should also recall that a capacitor is considered fully charged after five RC time constants. Referring to figure 3-16, you should see that to obtain a steady dc output voltage, the capacitor should charge rapidly and discharge as slowly as possible.

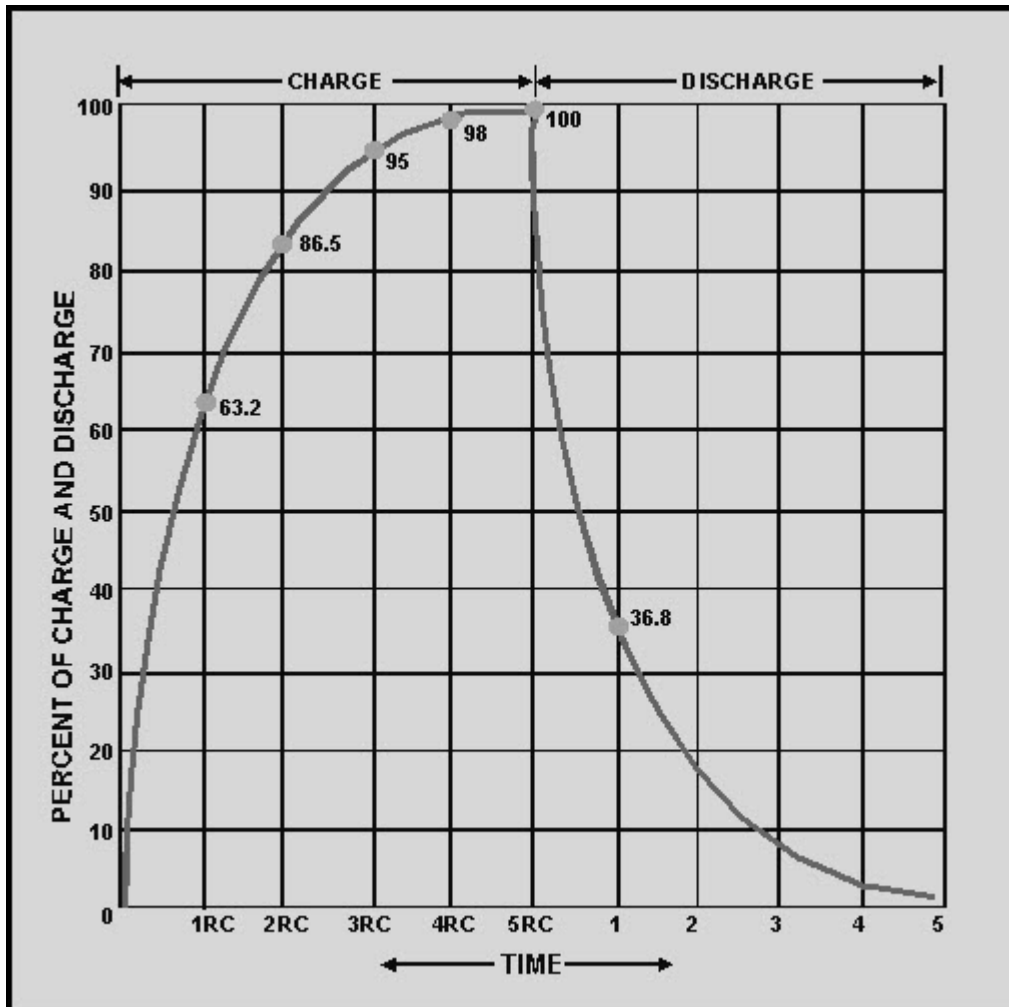

Figure 3-16 RC time constant chart

NEETS MODULE 6-Electronic Emission, Tubes, and Power Supplies UNCLASSIFIED

In filter circuits the capacitor is the common element to both the charge and discharge paths. Therefore, to obtain the longest possible discharge time, you want the capacitor to be as large as possible. Another way to look at this is: The capacitor acts as a short circuit around the load (as far as the ac component is concerned), and since

$$X_c = \frac{1}{2\pi fC}$$

the larger the value of the capacitor (C), the smaller the opposition (X_c) or resistance to ac.

Now let's look at inductors and their application in filter circuits. Remember, **AN INDUCTOR OPPOSES ANY CHANGE IN CURRENT**. In case you have forgotten, a change in current through an inductor produces a changing electromagnetic field. The changing field, in turn, cuts the windings of the wire in the inductor and thereby produces a counter-electromotive force (cemf). It is the cemf that opposes the change in circuit current. Opposition to a change in current at a given frequency is called inductive reactance (X_L) and is measured in ohms. The inductive reactance (X_L) of an inductor is determined by the applied frequency and the inductance of the inductor. Mathematically,

$$X_L = 2\pi fL$$

From the preceding formula, you know that if either frequency or inductance is increased, the X_L will increase. Since inductors are placed in series with the load (fig. 3-17), the larger the X_L , the larger the ac voltage developed across the inductor and the smaller the ac voltage developed across the load.

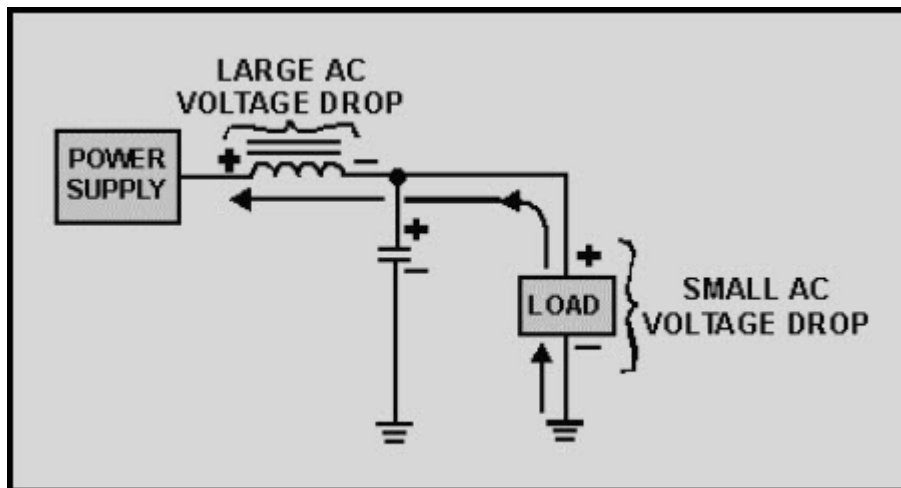

Figure 3-17 Voltage drops in an inductive filter

NEETS MODULE 6-Electronic Emission, Tubes, and Power Supplies UNCLASSIFIED

Now back to our circuit. As illustrated in figure 3-18, when the current starts to flow through the coil, an expanding magnetic field builds up around the inductor. This magnetic field around the coil develops the cemf that opposes the change in current. When the rectifier current decreases as shown in figure 3-19, the magnetic field collapses and again cuts the turns (windings) of wire, thus inducing current into the coil. This additional current adds to the rectifier current and attempts to keep it at its original level.

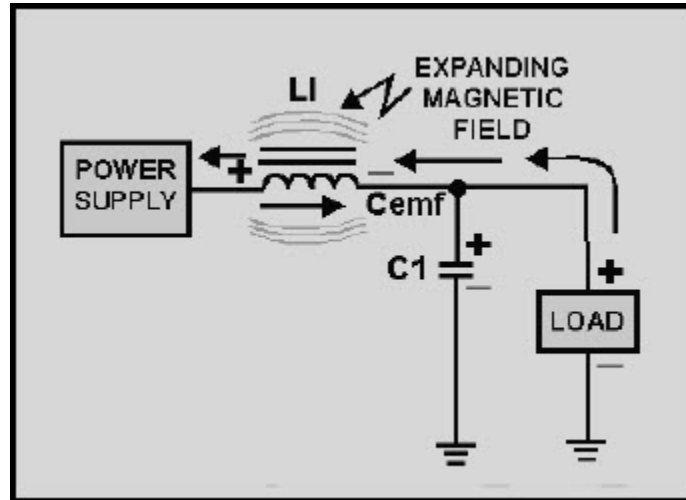

Figure 3-18 Inductive filter (expanding field)

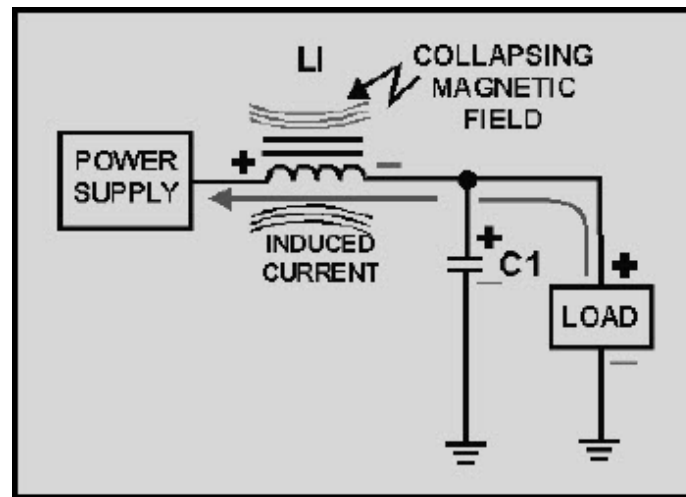

Figure 3-19 Inductive filter (collapsing field)

Now that you have learned how the components in the filter circuits react to current flow from the rectifier, let's discuss the different types of filter circuits in use today.

NEETS MODULE 6-Electronic Emission, Tubes, and Power Supplies UNCLASSIFIED

Q16. If you increase the value of the capacitor will the X_c increase or decrease? Why?

3.2.3.1 The Capacitor Filter

The simple capacitor filter is the most basic type of power supply filter. The use of this filter is very limited. It is sometimes used on extremely high-voltage, low-current power supplies for cathode-ray and similar electron tubes that require very little load current from the supply. This filter is also used in circuits where the power-supply ripple frequency is not critical and can be relatively high.

The simple capacitor filter shown in figure 3-20 consists of a single-filter element. This capacitor (C1) is connected across the output of the rectifier in parallel with the load. The RC charge time of the filter capacitor (C1) must be short and the RC discharge time must be long to eliminate ripple action when using this filter. In other words, the capacitor must charge up fast with preferably no discharge at all. Better filtering also results when the frequency is high; therefore, the full-wave rectifier output is easier to filter than the half-wave rectifier because of its higher frequency.

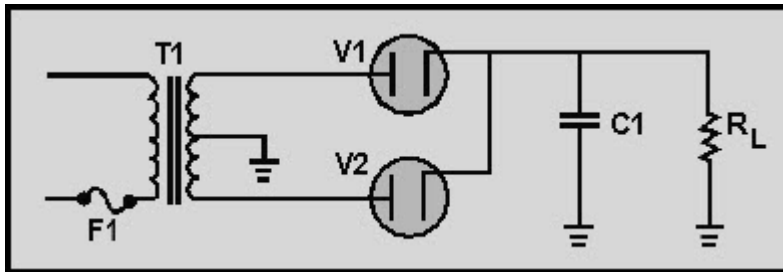

Figure 3-20 Full-wave rectifier with a capacitor filter

To understand better the effect that filtering has on E_{avg} , compare the rectifier circuits without filters in figure 3-21 to those with filters in figure 3-22. The output waveforms in figure 3-21 represent the unfiltered outputs of the half-wave and full-wave rectifier circuits. Current pulses flow through the load resistance (R_L) each time a diode conducts. The dashed line indicates the average value of output voltage. For the half-wave rectifier, E_{avg} is less than half the peak output voltage (or approximately 0.318 of the peak output voltage). For the full-wave rectifier, E_{avg} is approximately 0.637. This value is still much less than the applied voltage. With no capacitor connected across the output of the rectifier circuit, the waveform has a large pulsating component (ripple) compared with the average or dc component. Now refer to figure 3-22. When a capacitor is connected across the output (in parallel with R_L), the average value of output voltage (E_{avg}) is increased due to the filtering action of capacitor C1.

NEETS MODULE 6-Electronic Emission, Tubes, and Power Supplies
UNCLASSIFIED

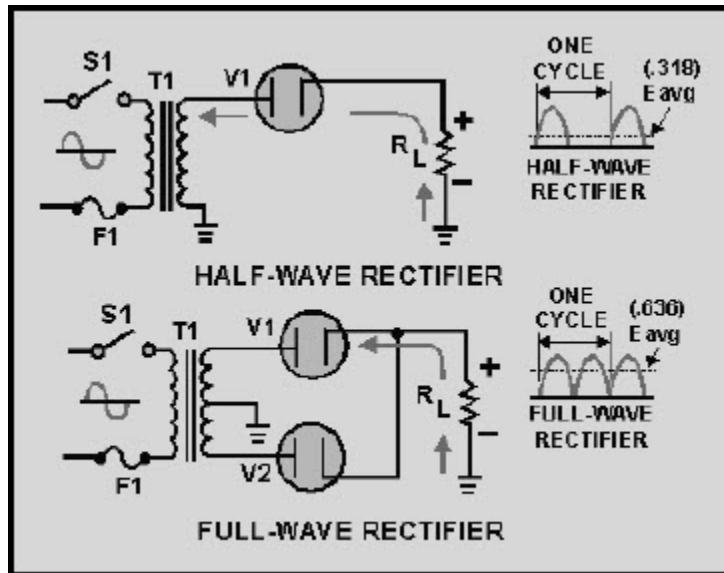

Figure 3-21 Half-wave/full-wave rectifiers (without filters)

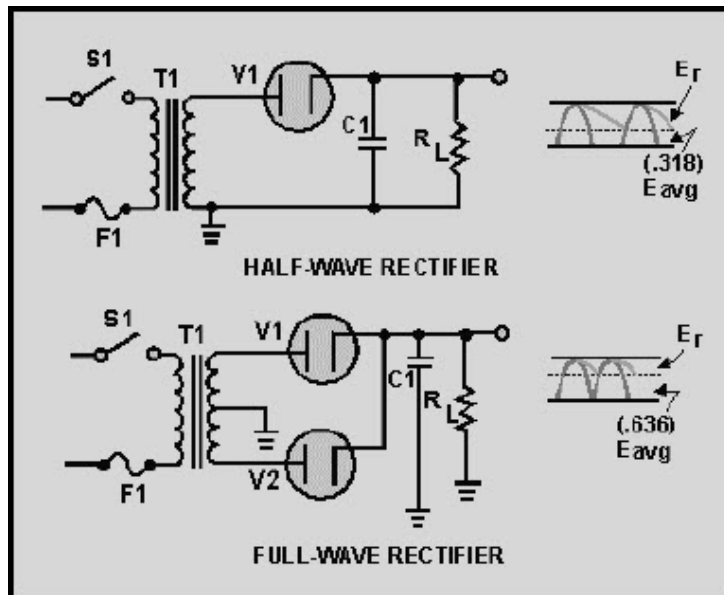

Figure 3-22 Half-wave/full-wave rectifiers (with capacitor filters)

NEETS MODULE 6-Electronic Emission, Tubes, and Power Supplies UNCLASSIFIED

The value of the capacitor is fairly large (several microfarads); it thus presents a relatively low reactance to the pulsating current and stores a substantial charge. The rate of charge for the capacitor is limited only by the relatively low resistance of the conducting diode. The RC charge time of the circuit is, therefore, relatively short. As a result, when the pulsating voltage is first applied to the circuit, the capacitor charges rapidly and almost reaches the peak value of the rectified voltage within the first few cycles. The capacitor attempts to charge to the peak value of the rectified voltage anytime a diode is conducting, and tends to retain its charge when the rectifier output falls to zero. (The capacitor cannot discharge immediately). The capacitor slowly discharges through the load resistance (R_L) during the time the rectifier is nonconducting.

The rate of discharge of the capacitor is determined by the value of capacitance and the value of the load resistance. If the capacitance and load resistance values are large, the RC discharge time for the circuit is relatively long.

From the waveforms shown in figure 3-22, you should see that the addition of C_1 to the circuit results in an increase in the average value of output voltage (E_{avg}) and a reduction in the amplitude of the ripple component (E_r) present across the load resistance.

Now, let's consider a complete cycle of operation using a half-wave rectifier, a capacitive filter (C_1), and a load resistor (R_L).

As shown in figure 3-23, C_1 is assumed to be large enough to ensure a small reactance to the pulsating rectified current. The resistance of R_L is assumed to be much greater than the reactance of C_1 at the input frequency.

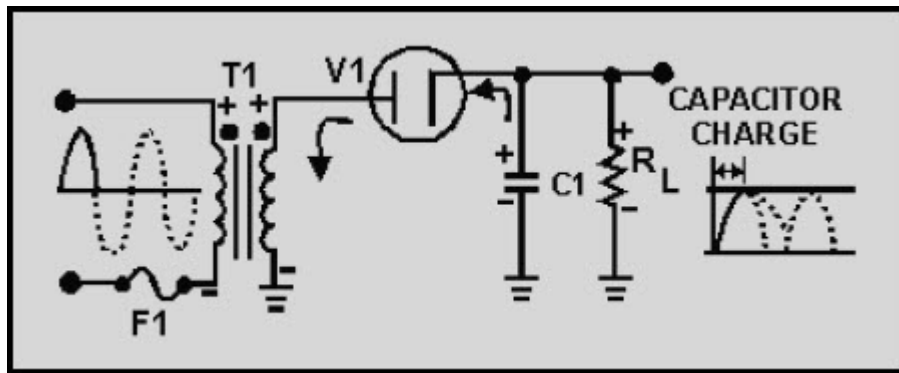

Figure 3-23 Half-wave rectifier capacitor filter (positive input cycle)

NEETS MODULE 6-Electronic Emission, Tubes, and Power Supplies UNCLASSIFIED

When the circuit is energized, the diode conducts on the positive half cycle and current flows through the circuit allowing C1 to charge. C1 will charge to approximately the peak value of the input voltage. The charge is less than the peak value because of the voltage drop across diode V1. The charge on C1 is indicated by the heavy, solid line on the waveform.

As illustrated in figure 3-24, the diode (V1) cannot conduct on the negative half cycle because the plate of V1 is negative in respect to the cathode. During this interval, C1 discharges through load resistance R_L . The discharge of C1 produces the downward slope indicated by the solid line on the waveform in the figure.

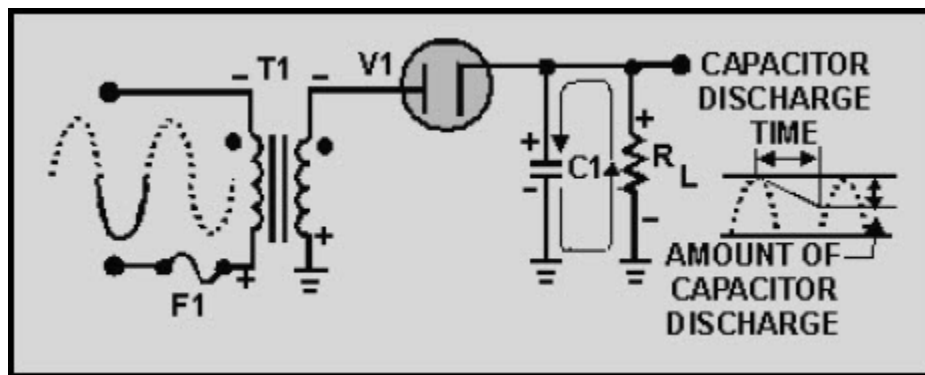

Figure 3-24 Half-wave rectifier capacitor filter (negative input cycle)

During the discharge period, in contrast to the abrupt fall of the applied ac voltage from peak value to zero, the voltage across C1 (and thus across R_L) gradually decreases until the time of the next half cycle of rectifier operation. Keep in mind that for good filtering, the filter capacitor should charge as fast as possible and discharge as little as possible.

Since practical values of C1 and R_L ensure a more or less gradual decrease of the discharge voltage, a substantial charge remains on the capacitor at the time of the next half cycle of operation. As a result, no current can flow through the diode until the rising ac input voltage at the plate of the diode exceeds the voltage of the charge remaining on C1. The charge on C1 is the cathode potential of the diode. When the potential on the plate exceeds the potential on the cathode (the charge on C1), the diode again conducts, and C1 commences to charge to approximately the peak value of the applied voltage.

After the capacitor has charged to its peak value, it begins to discharge. Since the fall of the ac input voltage on the plate is considerably more rapid than the decrease on the capacitor voltage, the cathode quickly becomes more positive than the plate, and the diode ceases to conduct.

NEETS MODULE 6-Electronic Emission, Tubes, and Power Supplies UNCLASSIFIED

The operation of the simple capacitor filter using a full-wave rectifier is basically the same as the operation we discussed for the half-wave rectifier. Notice in figure 3-25 that because one of the diodes is always conducting on either alternation, the filter capacitor charges and discharges during each half cycle. (Note that each diode conducts only for that portion of time when the peak secondary voltage is greater than the charge across the capacitor.)

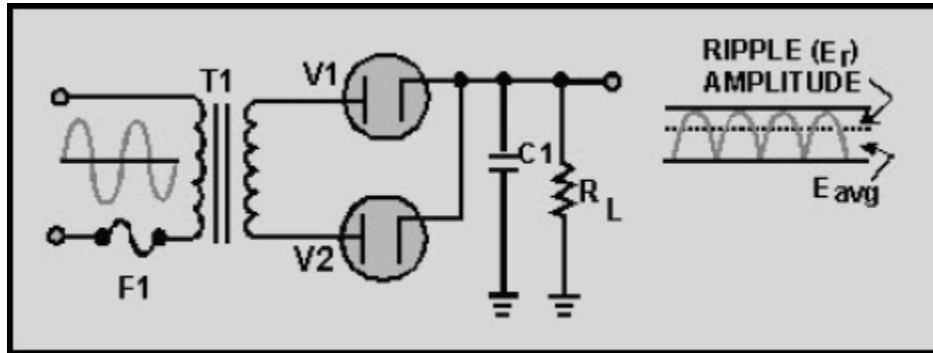

Figure 3-25 Full-wave rectifier (with capacitor filter)

We stated before that a major advantage of full-wave and bridge rectifiers over half-wave rectifiers is the ease of filtering their output voltages. You can now see the reason for this. The ripple frequency is doubled; therefore, the time period the capacitor is allowed to discharge is cut in half. This means that the capacitor discharges less. Thus, ripple amplitude is less, and a smoother output voltage occurs.

Another thing to keep in mind is that the ripple component (E_r) of the output voltage is an ac voltage and the average output voltage (E_{avg}) is the dc component of the output. Since the filter capacitor offers a relatively low impedance to ac, the majority of the ac component flows through the filter capacitor. The ac component is therefore bypassed (shunted) around the load resistance and the entire dc component (or E_{avg}) flows through the load resistance. To clarify this statement, let's take a look at the formula for X_c in a half-wave and full-wave rectifier. First, you must establish some values for the circuit.

NEETS MODULE 6-Electronic Emission, Tubes, and Power Supplies
UNCLASSIFIED

HALFWAVE RECTIFIER

FREQUENCY AT RECTIFIER OUTPUT: 60 Hz

VALUE OF FILTER CAPACITOR: 30 μ F

LOAD RESISTANCE: 10 k Ω

$$X_c = \frac{1}{2\pi fC}$$

$$X_c = \frac{.159}{fC}$$

$$X_c = \frac{.159}{60 \times .000030}$$

$$X_c = \frac{.159}{.0018}$$

$$X_c = 88.3 \Omega$$

FULLWAVE RECTIFIER

FREQUENCY AT OUTPUT: 120 Hz

VALUE OF FILTER CAPACITOR: 30 μ F

LOAD RESISTANCE: 10 k Ω

$$X_c = \frac{1}{2\pi fC}$$

$$X_c = \frac{.159}{fC}$$

$$X_c = \frac{.159}{120 \times .000030}$$

$$X_c = \frac{.159}{.0036}$$

$$X_c = 44.16 \Omega$$

NEETS MODULE 6-Electronic Emission, Tubes, and Power Supplies

UNCLASSIFIED

As you can see from the calculations, when the output frequency of the rectifier is doubled, the impedance of the capacitor is reduced by one-half. Therefore, when the simple capacitor filter is used in conjunction with a full-wave or bridge rectifier, improved filtering is provided because the increased ripple frequency decreases the capacitive reactance of the filter capacitor. This allows the ac component to be passed through the capacitor more easily. Therefore, the output of a full-wave rectifier is much easier to filter than that of a half-wave rectifier.

It should be obvious that the smaller the X_c of the filter capacitor in respect to the load resistance, the better the filtering action. By using the largest possible capacitor, we achieve the best filtering. The load resistance is also an important consideration. If load resistance is made small, the load current increases, and the average value of output voltage (E_{avg}) decreases. The RC discharge time constant is a direct function of the value of the load resistance; therefore, the rate of capacitor voltage discharge is a direct function of the current through the load. The greater the load current, the more rapid the discharge of the capacitor, and the lower the average value of output voltage. For this reason, the simple capacitor filter is seldom used with rectifier circuits that must supply a relatively large load current.

Q17. What is the most basic type of filter?

Q18. In a capacitor filter, is the capacitor in series or parallel with the load?

Q19. Is better filtering achieved at a high frequency or at a low frequency at the input of the filter?

Q20. Does a filter circuit increase or decrease the average output voltage?

Q21. What determines the rate of discharge of the capacitor in a filter circuit?

Q22. Does low ripple voltage indicate good or bad filtering?

Q23. Is a full-wave rectifier output easier to filter than that of a half-wave rectifier?

NEETS MODULE 6-Electronic Emission, Tubes, and Power Supplies

UNCLASSIFIED

In general, with the supply voltage removed from the input to the filter circuit, one terminal of the filter capacitor can be disconnected from the circuit.

CAUTION

REMEMBER-AN UNDISCHARGED CAPACITOR RETAINS ITS POLARITY AND HOLDS ITS CHARGE FOR LONG PERIODS OF TIME. TO BE SAFE, USE A PROPER SAFETY SHORTING PROBE TO DISCHARGE THE CAPACITOR TO BE TESTED WITH THE POWER OFF BEFORE CONNECTING TEST EQUIPMENT OR DISCONNECTING THE CAPACITOR.

You can check the capacitor by using a capacitance analyzer to determine its effective capacitance and leakage resistance. During these checks it is very important that you observe correct polarity if the capacitor is an electrolytic. A decrease in capacitance or losses within the capacitor can cause the output to be below normal and also cause excessive ripple amplitude.

If a suitable capacitance analyzer is not available, you can get an indication of leakage resistance by using an ohmmeter. You can make resistance measurements across the terminals of the capacitor to determine whether it is shorted, leaky, or open. When you test electrolytic capacitors, set the ohmmeter to the high range, and connect the test probes across the capacitor. Be careful to observe polarity. This is important because current flows through an electrolytic capacitor with less opposition in one direction than in the other. If you do not observe the correct polarity, you will get an incorrect reading and you may damage the meter. When you first connect the test probes, a large deflection of the meter should take place, and then the pointer should return slowly toward the infinite-ohms position as the capacitor charges. For a good capacitor with a rated working voltage of 450 volts dc, the final reading on the ohmmeter should be over 500,000 ohms. (A rough rule of thumb for high-voltage capacitors is at least 1000 ohms per volt.) Low-voltage electrolytic capacitors (below 100 volts rating) should indicate approximately 100,000 ohms.

If the ohmmeter does not deflect when you make the resistance check explained above, you have found an open-circuit capacitor.

A steady full-scale deflection of the pointer at zero ohms indicates that the capacitor being tested is shorted.

An indication of a leaky capacitor is a steady reading on the scale somewhere between zero and the minimum acceptable value. (Be certain this reading is not caused by an in-circuit shunting part.) To be valid, these capacitor checks should be made with the capacitor completely disconnected from the circuit in which it operates.

NEETS MODULE 6-Electronic Emission, Tubes, and Power Supplies UNCLASSIFIED

In high-voltage filter capacitor applications, paper and oil-filled capacitors are used in addition to mica and ceramic capacitors (for low-capacitance values). In this case, polarity is of no importance unless the capacitor terminals are marked plus or minus. It is, however, good maintenance practice to use the output polarity of the circuit as a guide, connecting positive to positive, and negative to negative. Thus, any adverse effects of polarity on circuit tests are minimized and the possibility of damage to components or to test equipment is eliminated.

3.2.3.2 The LC Choke-Input Filter

The LC choke-input filter is used primarily in power supplies where good voltage regulation is important and where the output current is relatively high and subject to varying load conditions. This filter is used in high-power applications such as those found in radar and communication transmitter power supplies.

In figure 3-26 you can see that this filter consists of an input inductor or filter-choke (L1) and an output filter capacitor (C1).

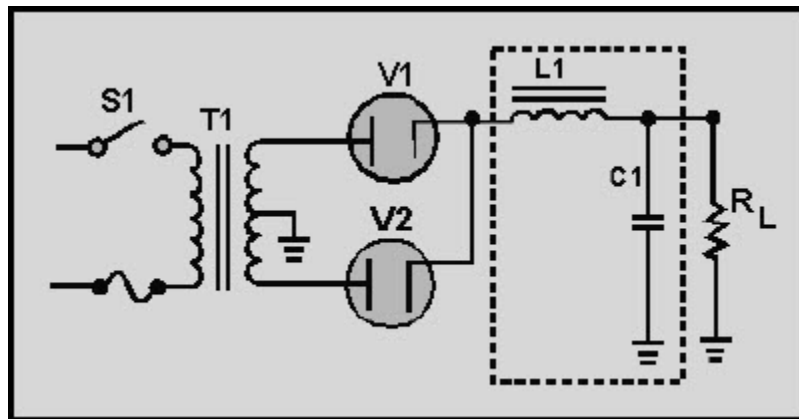

Figure 3-26 Full-wave rectifier LC choke-input filter

Inductor L1 is placed at the input to the filter and is in series with the output of the rectifier circuit. Since the action of an inductor is to oppose any change in current flow, the inductor tends to keep a constant current flowing to the load throughout the complete cycle of the applied voltage. As a result, the output voltage never reaches the peak value of the applied voltage; instead, the output voltage approximates the average value of the rectified input to the filter, as shown in figure 3-27.

NEETS MODULE 6-Electronic Emission, Tubes, and Power Supplies
UNCLASSIFIED

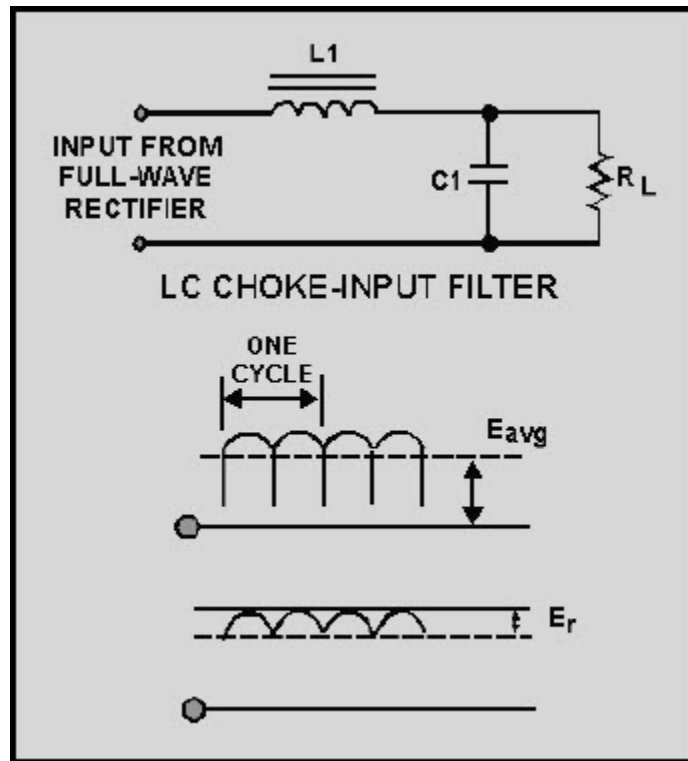

Figure 3-27 Waveforms for an LC choke-input filter

The reactance of the inductor (X_L) reduces the amplitude of ripple voltage without reducing the dc output voltage by an appreciable amount. (The dc resistance of the inductor is just a few ohms.)

The shunt capacitor (C_1) charges and discharges at the ripple frequency rate, but the amplitude of the ripple voltage (E_r) is relatively small because the inductor (L_1) tends to keep a constant current flowing from the rectifier circuit to the load. In addition, the reactance of the shunt capacitor (X_C) presents a low impedance to the ripple component existing at the output of the filter, and thus shunts the ripple component around the load. The capacitor attempts to hold the output voltage relatively constant at the average value of the voltage.

NEETS MODULE 6-Electronic Emission, Tubes, and Power Supplies UNCLASSIFIED

The value of the filter capacitor (C_1) must be relatively large to present a low opposition (X_c) to the pulsating current and to store a substantial charge. The rate of the charge for the capacitor is limited by the low impedance of the ac source (transformer), the small resistance of the diode, and the counter emf developed by the coil. Therefore, the RC charge time constant (fig. 3-28) is short compared to its discharge time.

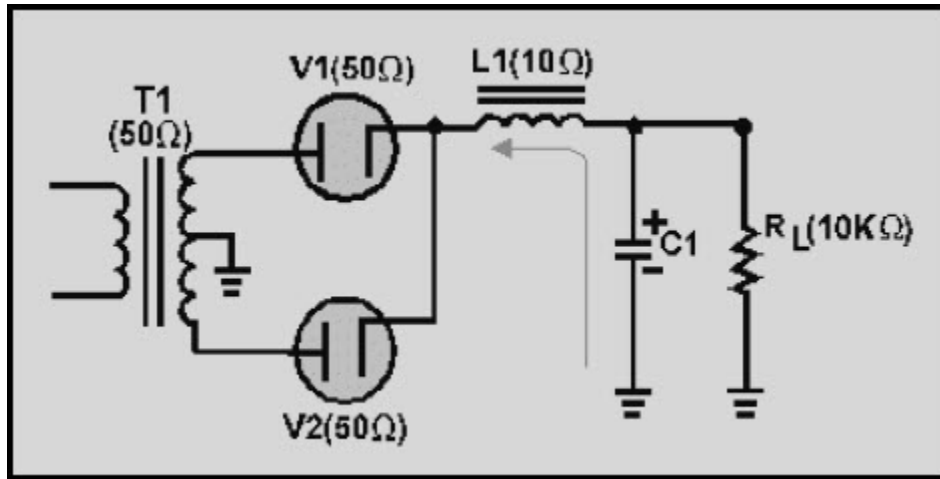

Figure 3-28 LC choke-input filter (circuit resistance)

As a result, when the pulsating voltage is first applied to the LC choke-input filter, the inductor or filter choke (L_1) produces a counter emf that opposes the constantly increasing input voltage. The net result is to effectively prevent the rapid charging of the filter capacitor (C_1). Thus, instead of reaching the peak value of the input voltage, C_1 only charges to the average value of the input voltage. After the input voltage reaches its peak and decreases sufficiently, the capacitor (C_1) attempts to discharge through the load resistance (R_L). C_1 will attempt to discharge as indicated in figure 3-29. Because of its relatively long discharge time constant, C_1 can only partially discharge.

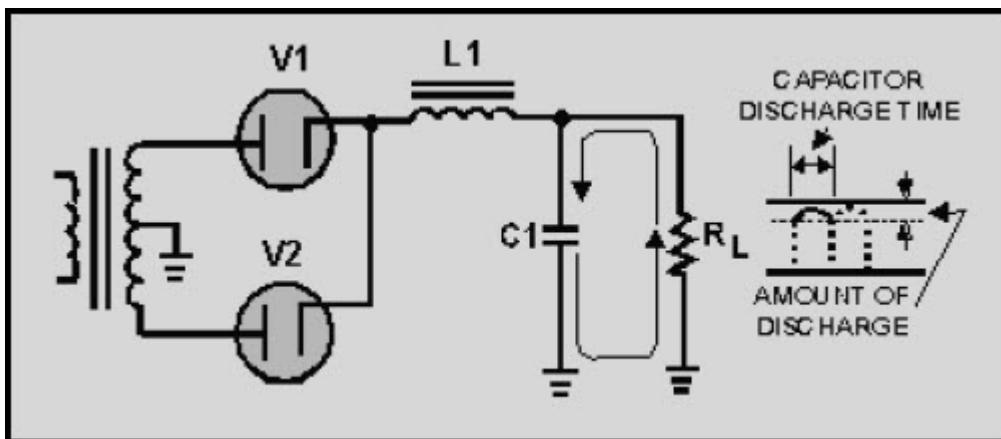

Figure 3-29 LC choke-input filter (discharge path)

NEETS MODULE 6-Electronic Emission, Tubes, and Power Supplies UNCLASSIFIED

The larger the value of the filter capacitor, the better the filtering action. However, due to the physical size, there is a practical limitation to the maximum value of the capacitor.

The inductor or filter choke (L_1) maintains the current flow to the filter output (capacitor C_1 and load resistance R_L) at a nearly constant level during the charge and discharge periods of the filter capacitor.

The series inductor (L_1) and the capacitor (C_1) form a voltage divider for the ac component (ripple) of the applied input voltage. This is shown in figure 3-30. As far as the ripple component is concerned, the inductor offers a high impedance (Z) and the capacitor offers a low impedance. As a result, the ripple component (E_r) appearing across the load resistance is greatly attenuated (reduced). Since the inductance of the filter choke opposes changes in the value of the current flowing through it, the average value of the voltage produced across the capacitor contains a much smaller value of ripple component (E_r), as compared with the value of ripple produced across the coil.

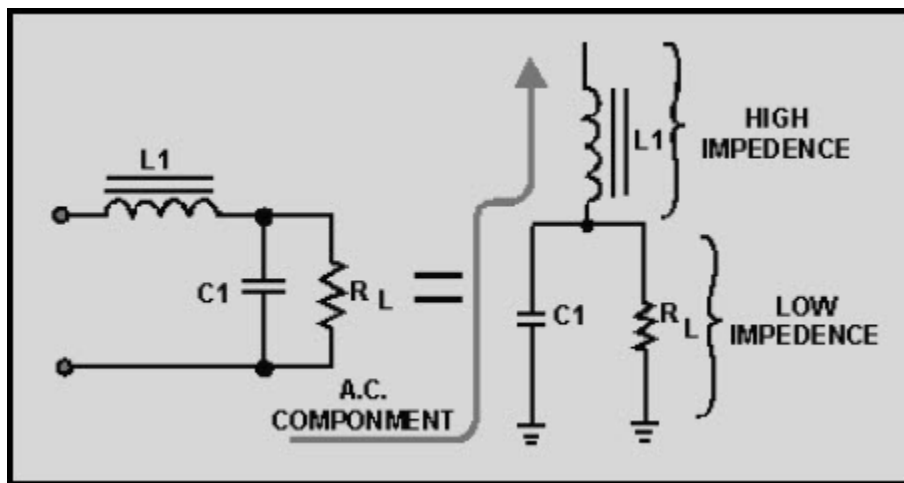

Figure 3-30 LC choke-input filter (as voltage divider)

NEETS MODULE 6-Electronic Emission, Tubes, and Power Supplies UNCLASSIFIED

Now look at figure 3-31, which illustrates a complete cycle of operation where a full-wave rectifier circuit is used to supply the input voltage to the filter. The rectifier voltage is developed across capacitor C1. The ripple voltage in the output of the filter is the alternating component of the input voltage reduced in amplitude by the filter section.

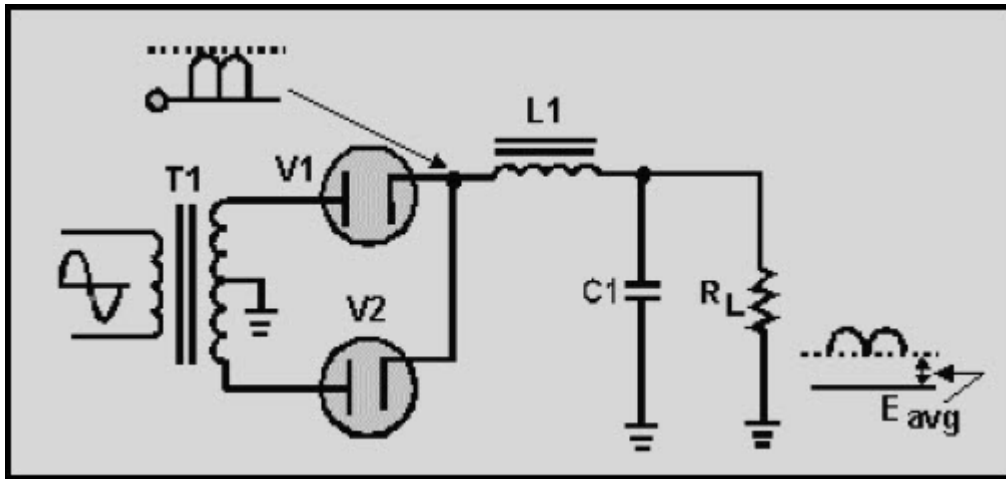

Figure 3-31 Filtering action of an LC choke-input filter

Each time the plate of a diode goes positive with respect to the cathode, the diode conducts and C1 charges. Conduction occurs twice during each cycle for a full-wave rectifier. For a 60-hertz supply, this produces a ripple frequency of 120 hertz. Although the diodes alternate (one conducts while the other is nonconducting), the filter input voltage is not steady. As the plate voltage of the conducting diode increases (on the positive half of the cycle), capacitor C1 charges—the charge being limited by the impedance of the secondary transformer winding, the diode's forward (cathode-to-plate) resistance, and the counter emf developed by the choke. During the nonconducting interval, when the plate voltage drops below the capacitor charge voltage, C1 discharges through the load resistance R_L . The components in the discharge path cause a long time constant; thus C1 discharges slower than it charges.

The choke (L1) is usually of a large value, on the order of 1 to 20 henries, and offers a large inductive reactance to the 120-hertz ripple component produced by the rectifier. Therefore, the effect that L1 has on the charging of the capacitor (C1) must be considered. Since L1 is connected in series with the parallel branch consisting of C1 and R_L , a division of the ripple ac voltage and the output dc voltage occurs. The greater the impedance of the choke, the less the ripple voltage that appears across C1 and the output. The dc output voltage is fixed mainly by the dc resistance of the choke.

NEETS MODULE 6-Electronic Emission, Tubes, and Power Supplies UNCLASSIFIED

Now that you have read how the LC choke-input filter functions, let's take a look at it using actual component values. For simplicity, the input frequency at the primary of the transformer will be 117 volts 60 hertz. We will use both half-wave and full-wave rectifier circuits to provide the input to the filter.

Starting with the half-wave configuration as shown in figure 3-32, the basic parameters are: with 117 volts ac rms applied to the T1 primary, 165 volts ac peak-to-peak is available at the secondary $[(117 \text{ V}) \times (1.414) = 165 \text{ V}]$. You should recall that the ripple frequency of this half-wave rectifier is 60 hertz. Therefore, the capacitive reactance of C1 is:

$$X_c = \frac{1}{2\pi fC}$$
$$X_c = \frac{1}{(2)(3.14)(60)(10)(10^{-6})}$$
$$X_c = \frac{(1)(10^6)}{3768}$$
$$X_c = 265 \Omega$$

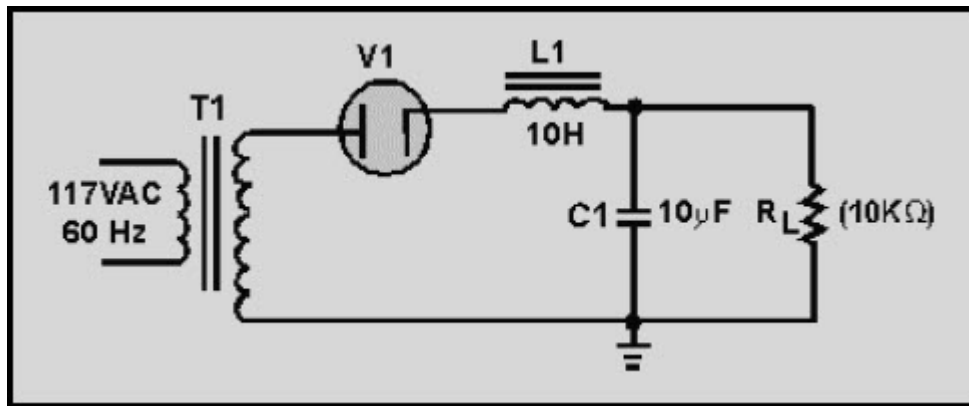

Figure 3-32 Half-wave rectifier with an LC choke-input filter

NEETS MODULE 6-Electronic Emission, Tubes, and Power Supplies

UNCLASSIFIED

This means that the capacitor (C1) offers 265 ohms of opposition to the ripple current. Note, however, that the capacitor offers an infinite impedance to direct current. The inductive reactance of L1 is:

$$X_L = 2\pi fL$$

$$X_L = (2) (3.14) (60) (10)$$

$$X_L = 3.8 \text{ Kilohms}$$

This shows that L1 offers a relatively high opposition (3.8 kilohms) to the ripple in comparison to the opposition offered by C1 (265 ohms). Thus, more ripple voltage will be dropped across L1 than across C1. In addition, the impedance of C1 (265 ohms) is relatively low in respect to the resistance of the load (10 kilohms). Therefore, more ripple current flows through C1 than the load. In other words, C1 shunts most of the ac component around the load.

Let's go a step further and redraw the filter circuit so that you can see the voltage divider action. (Refer to figure 3-33.) Remember, the 165 volts peak-to-peak 60 hertz provided by the rectifier consist of both an ac and a dc component. The first discussion will be about the ac component. Looking at figure 3-33, you see that the capacitor (C1) offers the least opposition (265 ohms) to the ac component; therefore, the greatest amount of ac will flow through C1. (The heavy line indicates current flow through the capacitor.) Thus the capacitor bypasses, or shunts, most of the ac around the load.

By combining the X_C of C1 and the resistance of R_L into an equivalent circuit, you will have an equivalent impedance of 265 ohms.

NEETS MODULE 6-Electronic Emission, Tubes, and Power Supplies
UNCLASSIFIED

$$Z = \frac{R \times X_c}{\sqrt{(R^2 + X_c^2)}}$$

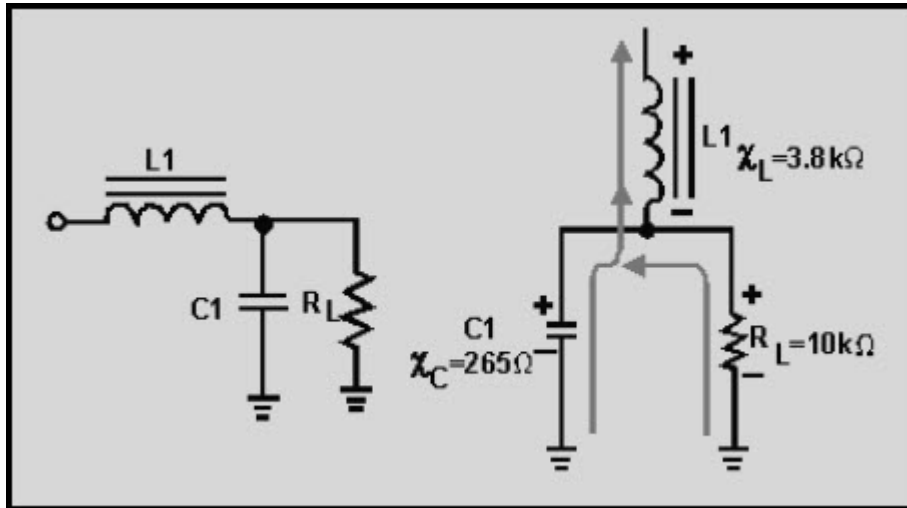

Figure 3-33 AC component in an LC choke-input filter

You now have a voltage divider as illustrated in figure 3-34. You should see that because of the impedance ratios, a large amount of ripple voltage is dropped across L1, and a substantially smaller amount is dropped across C1 and RL. You can further increase the ripple voltage across L1 by increasing the inductance:

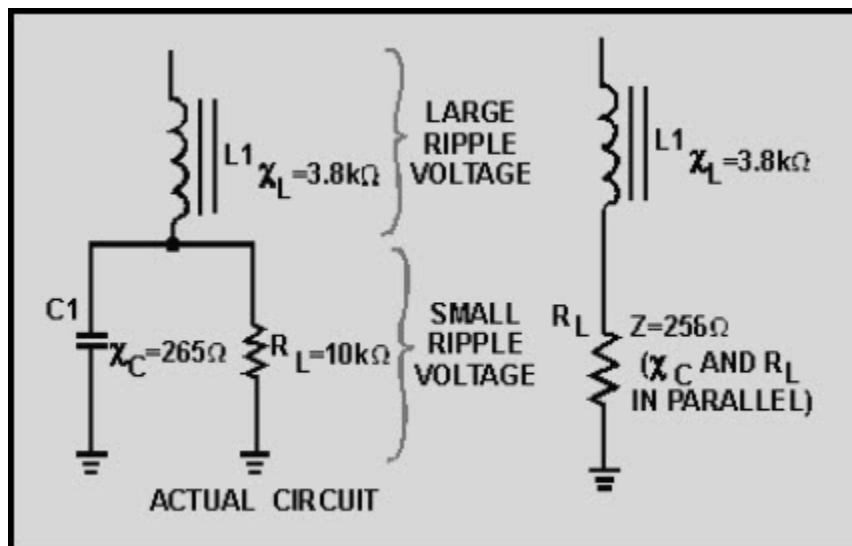

Figure 3-34 Actual and equivalent circuits

NEETS MODULE 6-Electronic Emission, Tubes, and Power Supplies UNCLASSIFIED

Now let's discuss the dc component of the applied voltage. Remember, a capacitor offers an infinite (∞) impedance to the flow of direct current. The dc component, therefore, must flow through R_L and $L1$. As far as the dc is concerned, the capacitor does not exist. The coil and the load are, therefore, in series with each other. The dc resistance of a filter choke is very low (50 ohms average). Therefore, most of the dc component is developed across the load and a very small amount of the dc voltage is dropped across the coil, as shown in figure 3-35.

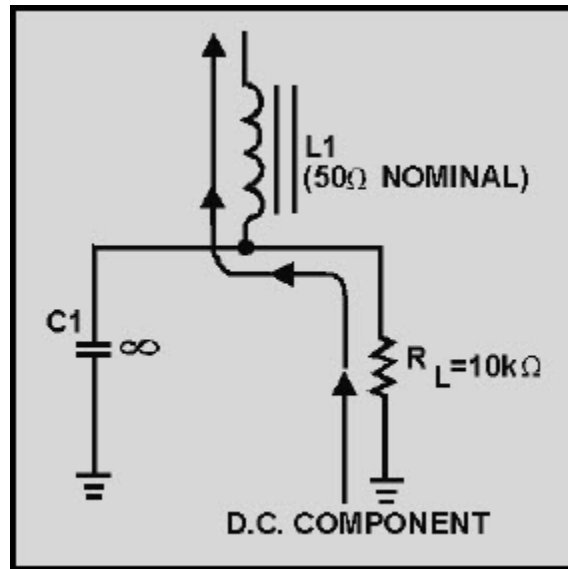

Figure 3-35 DC component in an LC choke-input filter

As you may have noticed, both the ac and the dc components flow through $L1$, and because the coil is frequency sensitive, it provides a large resistance to ac and a small resistance to dc. In other words, the coil opposes any change in current. This property makes the coil a highly desirable filter component.

NEETS MODULE 6-Electronic Emission, Tubes, and Power Supplies UNCLASSIFIED

Note that the filtering action of the LC capacitor input filter is improved when the filter is used in conjunction with a full-wave rectifier as shown in figure 3-36. This is due to the decrease in the X_c of the filter capacitor and the increase in the X_L of the choke. Remember, the ripple frequency of a full-wave rectifier is twice that of a half-wave rectifier. For a 60-hertz input, the ripple will be 120 Hertz. Let's briefly calculate the X_c of C1 and the X_L of L1:

$$X_c = \frac{1}{2\pi fC}$$

$$X_c = \frac{1}{(2)(3.14)(120)(10)(10^{-6})}$$

$$X_c = \frac{(1)(10^6)}{7536}$$

$$X_c = 132.5 \Omega$$

$$X_L = 2\pi fL$$

$$X_L = (2)(3.14)(120)(10)$$

$$X_L = 7.5 \text{ Kilohms}$$

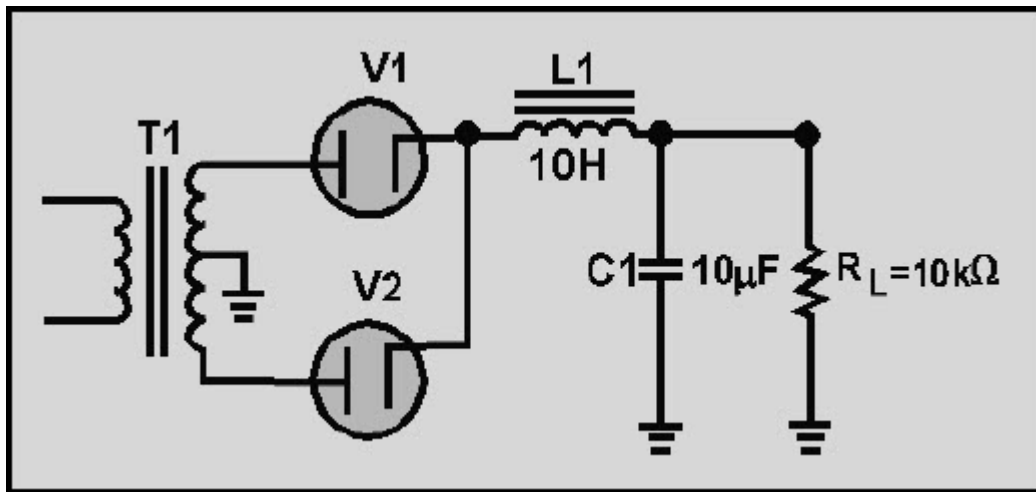

Figure 3-36 Full-wave rectifier with an LC choke-input filter

NEETS MODULE 6-Electronic Emission, Tubes, and Power Supplies

UNCLASSIFIED

It should be apparent that when the X_C of a filter capacitor is decreased, it provides less opposition to the flow of ac. The greater the ac flow through the capacitor, the lower the flow through the load. Conversely, the larger the X_L of the choke, the greater the amount of ac ripple developed across the choke; consequently, less ripple is developed across the load. This condition provides better filtering.

Q24. In an LC choke-input filter, what prevents the rapid charging of the capacitor?

Q25. What is the value usually chosen for a filter choke?

Q26. If the inductance of a choke-input filter is increased, will the output ripple voltage amplitude (E_r) increase or decrease?

An LC choke-input filter is subject to several problems that can cause it to fail. The filter capacitors are subject to open circuits, short circuits, and excessive leakage. The series inductor is subject to open windings and, occasionally, shorted turns or a short circuit to the core.

The filter capacitor in the choke-input filter circuit is not subject to extreme voltage surges because of the protection offered by the inductor; however, the capacitor can become open, leaky, or shorted.

Shorted turns in the choke may reduce the value of inductance below the critical value. This will result in excessive peak-rectifier current, accompanied by an abnormally high output voltage, excessive ripple amplitude, and poor voltage regulation. A choke winding that is open, or a choke winding that is shorted to the core will result in a no-output condition. A choke winding that is shorted to the core may cause overheating of the rectifier element(s), blown fuses, and so forth.

To check the capacitor, first remove the supply voltage from the input to the filter circuit. Then disconnect one terminal of the capacitor from the circuit. Check the capacitor with a capacitance analyzer to determine its capacitance and leakage resistance. When the capacitor is electrolytic, be sure to use the correct polarity at all times. A decrease in capacitance or losses within the capacitor can decrease the efficiency of the filter and produce excessive ripple amplitude. If a suitable capacitance analyzer is not available, you can use an ohmmeter to check for leakage resistance. The test procedure is the same as that described for the input capacitor filter.

NEETS MODULE 6-Electronic Emission, Tubes, and Power Supplies UNCLASSIFIED

So far, this section has discussed in detail the operation and troubleshooting of the basic inductive and capacitive filter circuits. For the two remaining types of filters, we will discuss only the differences between them and the other basic filters.

3.2.3.3 Resistor-Capacitor (RC) Filters

The RC capacitor-input filter is limited to applications in which the load current is small. This type of filter is used in power supplies where the load current is constant and voltage regulation is not necessary. For example, RC filters are used in high-voltage power supplies for cathode-ray tubes and as part of decoupling networks for multistage amplifiers.

Figure 3-37 shows an RC capacitor-input filter and its associated waveforms. Both half-wave and full-wave rectifiers are used to provide the inputs.

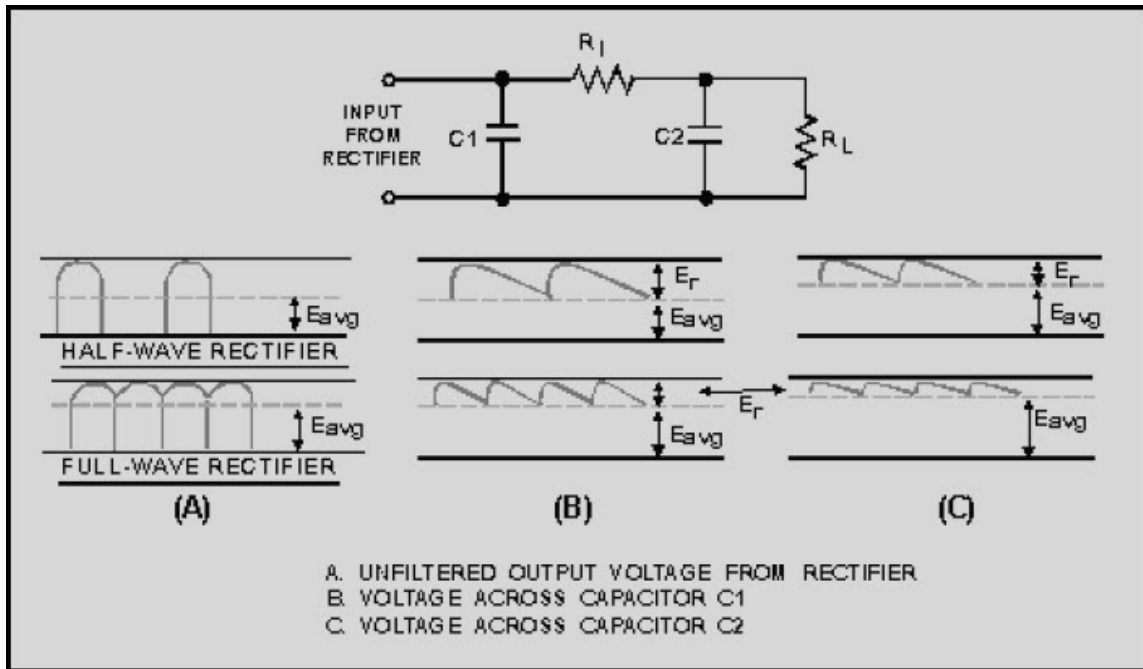

Figure 3-37 RC filter and waveforms

The RC filter in figure 3-37 consists of an input filter capacitor (C1), a series resistor (R1), and an output filter capacitor (C2). Although not part of the RC filter, R_L is shown to help explain the circuit. This filter is sometimes referred to as an RC *pi-section filter* because its schematic symbol resembles the Greek letter π .

NEETS MODULE 6-Electronic Emission, Tubes, and Power Supplies

UNCLASSIFIED

Although the single capacitor filter is suitable for many noncritical, low-current applications, when the load resistance is very low or when the percent of ripple must be held to an absolute minimum, the capacitor must have an extremely large value. While electrolytic capacitors are available in sizes up to 10,000 μF or greater, the larger sizes are quite expensive. A more practical approach is to use a more sophisticated filter that can do the same job but that has lower capacitor values, such as the RC filter.

The waveforms shown in the figure represent the unfiltered output from a typical rectifier circuit. Note that the dashed line, which indicates the average value of output voltage (E_{avg}) for the half-wave rectifier, is less than half the amplitude of the voltage peaks (approximately 0.318). The average value of output voltage (E_{avg}) for the full-wave rectifier is greater than half (approximately 0.637), but is still much less than the peak amplitude of the rectifier-output waveform. With no filter circuit connected across the output of the rectifier circuit (unfiltered), the waveform has a large value of pulsating component (ripple) as compared to the average (or dc) component.

An RC filter, such as a pi-section filter, does a much better job than a single capacitor filter.

Figure 3-37 illustrates an RC filter connected across the output of a rectifier. C1 performs the same function that it did in the single capacitor filter. It is used to reduce the percentage of ripple to a relatively low value. Thus, the voltage across C1 might consist of an average dc value of +100 volts with a ripple voltage of 10 volts. This voltage is passed on to the R1-C2 network, which reduces the ripple even further (view C).

C2 offers an infinite impedance (resistance) to the dc component of the output voltage. Thus, the dc voltage is passed to the load, but reduced in value by the amount of the voltage drop across R1. However, R1 is generally small compared to the load resistance. Therefore, the drop in the dc voltage by R1 is not a drawback.

Component values are designed so that the resistance of R1 is much greater than the reactance of C2 at the ripple frequency. C2 offers a very low impedance to the ac ripple frequency. Thus, the ac ripple senses a voltage divider consisting of R1 and C2 between the output of the rectifier and ground. Therefore, most of the ripple voltage is dropped across R1. Only a trace of the ripple voltage can be seen across C2 and the load.

In extreme cases where the ripple must be held to an absolute minimum, a second stage of RC filtering can be added. In practice, the second stage is rarely required. The RC filter is extremely popular because smaller capacitors can be used with good results.

The RC filter has some disadvantages, however. First, the voltage drop across R1 takes voltage away from the load. Second, power is wasted in R1 and is dissipated in the form of unwanted heat.

NEETS MODULE 6-Electronic Emission, Tubes, and Power Supplies UNCLASSIFIED

Finally, if the load resistance changes, the voltage across the load will change. Even so, the advantages of the RC filter overshadow these disadvantages in many cases.

Q27. Is an RC filter used when a large current or a small current demand is required?

Q28. Why is the use of large value capacitors in filter circuits discouraged?

Q29. When is a second RC filter stage used?

The resistor-capacitor (RC) filter is also subject to problems that can cause it to fail. The shunt capacitors (C1 and C2) are subject to an open circuit, a short circuit, or excessive leakage. The series filter resistor (R1) is subject to changes in value and occasionally opens. Any of these troubles can be easily detected.

The input capacitor (C1) has the greatest pulsating voltage applied to it and is the most susceptible to voltage surges. As a result, it is frequently subject to voltage breakdown and shorting. The remaining shunt capacitor (C2) in the filter circuit is not subject to voltage surges because of the protection offered by the series filter resistor (R1). However, a shunt capacitor can become open, leaky, or shorted.

A shorted capacitor or an open filter resistor results in a no-output indication. An open filter resistor results in an abnormally high dc voltage at the input to the filter and no voltage at the output of the filter. Leaky capacitors or filter resistors that have lost their effectiveness, or filter resistors that have decreased in value, result in excessive ripple amplitude in the output of the supply.

NEETS MODULE 6-Electronic Emission, Tubes, and Power Supplies

UNCLASSIFIED

3.2.3.4 LC Capacitor-Input Filter

The LC input filter is one of the most commonly used filters. This type of filter is used primarily in radio receivers, small audio amplifier power supplies, and in any type of power supply where the output current is low and the load current is relatively constant.

Figure 3-38 shows an LC capacitor-input filter and its associated waveforms. Both half-wave and full-wave rectifier circuits are used to provide the inputs.

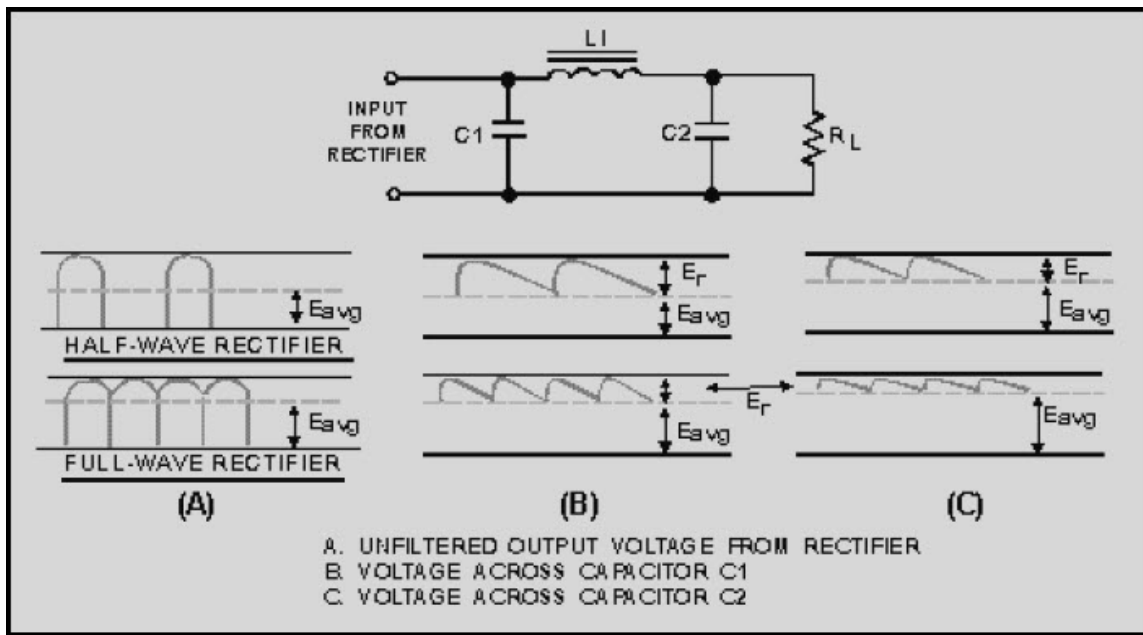

Figure 3-38 LC capacitor-input filter and waveforms

The waveforms shown in the figure represent the unfiltered output from a typical rectifier circuit. Note again, that the average value of output voltage (E_{avg}) for the half-wave rectifier is less than half the amplitude of the voltage peaks. This is indicated by the dashed line. The average value of output voltage (E_{avg}) for the full-wave rectifier is greater than half, but is still much less than the peak amplitude of the rectifier-output waveform. With no filter circuit connected across the output of the rectifier circuit (unfiltered), the waveform has a large value of pulsating component (ripple) as compared to the average (or dc) component.

NEETS MODULE 6-Electronic Emission, Tubes, and Power Supplies

UNCLASSIFIED

A common type of LC filter is shown in figure 3-38. C1 performs the same functions as discussed earlier by reducing the ripple to a relatively low level. L1 and C2 form the LC filter, which reduces the ripple even further (view C).

L1 is a large value iron-core inductor (choke.) It has a high value of inductance and, therefore, a high value of X_L , which offers a high reactance to the ripple frequency. At the same time, C2 offers a very low reactance to the ac ripple. L1 and C2 form an ac voltage divider and, because the reactance of L1 is much higher than that of C2, most of the ripple voltage is dropped across L1. Only a slight trace of the ripple appears across C2 and the load.

While the L1-C2 network greatly reduces the ac ripple, it has little effect on the dc. You should recall that an inductor offers no reactance to dc. The only opposition to current flow is the resistance of the wire in the choke. Generally, this resistance is very low and the dc voltage drop across the coil is minimal. Thus, the LC filter overcomes the disadvantages of the RC filter.

Aside from the voltage divider effect, the inductor improves filtering in another way. You should recall that an inductor resists changes in the magnitude of the current flowing through it. Consequently, when the inductor is placed in series with the load, the inductor tends to hold the current steady. This, in turn, helps to hold the voltage across the load constant.

The LC filter provides good filtering action over a wide range of currents. The capacitor filters best when the load is drawing little current. Thus, the capacitor discharges very slowly and the output voltage remains almost constant. On the other hand, the inductor filters best when the current is highest. The complementary nature of these components ensures good filtering over a wide range of current when size of components is a factor.

The LC filter has two disadvantages. The first is cost. The LC filter is more expensive than the RC filter because its iron-core choke costs more than the resistor of the RC filter. The second disadvantage is size, since the iron-core choke is bulky and heavy. Thus, the LC filter may be unsuitable for some applications but is still one of the most widely used.

Q30. What is the most commonly used filter in use today?

Q31. What are the two main disadvantages of an LC capacitor filter?

NEETS MODULE 6-Electronic Emission, Tubes, and Power Supplies

UNCLASSIFIED

Several problems may cause the LC capacitor filter to fail. Shunt capacitors are subject to open circuits, short circuits, and excessive leakage; series inductors are subject to open windings and occasionally shorted turns or a short circuit to the core.

The input capacitor (C1) has the greatest pulsating voltage applied to it, is the most susceptible to voltage surges, and has a generally higher average voltage applied. As a result, the input capacitor is frequently subject to voltage breakdown and shorting. The output capacitor (C2) is not as susceptible to voltage surges because of the series protection offered by the series inductor (L1), but the capacitor can become open, leaky, or shorted.

A shorted capacitor, an open filter choke, or a choke winding that is shorted to the core, results in a no-output indication. A shorted capacitor, depending on the magnitude of the short, may cause a shorted rectifier, transformer, or filter choke and result in a blown fuse in the primary of the transformer. An open filter choke results in an abnormally high dc voltage at the input to the filter and no voltage at the output of the filter. A leaky or open capacitor in the filter circuit results in a low dc output voltage. This condition is generally accompanied by excessive ripple amplitude. Shorted turns in the winding of a filter choke reduce the effective inductance of the choke and decrease its filtering efficiency. As a result, the ripple amplitude increases.

3.2.4 Voltage Regulation

Ideally, the output of most power supplies should be a constant voltage. Unfortunately, this is difficult to achieve. There are two factors that can cause the output voltage to change. First, the ac line voltage is not constant. The so-called *115 volts ac* can vary from about 105 volts ac to 125 volts ac. This means that the peak ac voltage to which the rectifier responds can vary from about 148 volts to 177 volts. The ac line voltage alone can be responsible for nearly a 20 percent change in the dc output voltage.

The second factor that can change the dc output voltage is a change in the load resistance. In complex electronic equipment, the load can change as circuits are switched in and out. In a television receiver, the load on a particular power supply may depend on the brightness of the screen, the control settings, or even the channel selected.

These variations in load resistance tend to change the applied dc voltage because the power supply has a fixed internal resistance. If the load resistance decreases, the internal resistance of the power supply drops more voltage. This causes a decrease in the voltage across the load.

NEETS MODULE 6-Electronic Emission, Tubes, and Power Supplies

UNCLASSIFIED

Many circuits are designed to operate with a particular supply voltage. When the supply voltage changes, the operation of the circuit may be adversely affected. Consequently, some types of equipment must have power supplies that produce the same output voltage regardless of changes in the load resistance or changes in the ac line voltage. This constant supply of power may be achieved by adding a circuit called the **VOLTAGE REGULATOR** at the output of the filter.

3.2.5 Load Regulation

A commonly used **FIGURE OF MERIT** for a power supply is its **PERCENT OF REGULATION**. The figure of merit gives us an indication of how much the output voltage changes over a range of load resistance values. The percent of regulation aids us in determining of the type of load regulation needed. Percent of regulation is determined by the equation:

$$\text{Percent of regulation} = \frac{(E_{nL} - E_{fL})}{E_{fL}} \times 100$$

This equation compares the change in output voltage at the two loading extremes to the voltage produced at full loading. For example, assume that a power supply produces 12 volts when the load current is zero. If the output voltage drops to 10 volts when full load current flows, then the percent of regulation is:

$$\text{Percent of regulation} = \frac{(E_{nL} - E_{fL})}{E_{fL}} \times 100$$

$$\text{Percent of regulation} = \frac{(12 - 10V)}{10V} \times 100$$

$$\text{Percent of regulation} = \frac{2V}{10V} \times 100$$

$$\text{Percent of regulation} = 20\%$$

NEETS MODULE 6-Electronic Emission, Tubes, and Power Supplies
UNCLASSIFIED

Ideally, the output voltage should not change over the full range of operation. That is, a 12-volt power supply should produce 12 volts at no load, at full load, and at all points in between. In this case, the percent of regulation would be:

$$\text{Percent of regulation} = \frac{(E_{nL} - E_{fL})}{E_{fL}} \times 100$$

$$\text{Percent of regulation} = \frac{(12 - 12V)}{12V} \times 100$$

$$\text{Percent of regulation} = \frac{0V}{12V} \times 100$$

$$\text{Percent of regulation} = 0\%$$

Thus, zero-percent load regulation is the ideal situation. It means that the output voltage is constant under all load conditions. While you should strive for zero percent load regulation, in practical circuits you must settle for something less. Even so, by using a voltage regulator, you can hold the percent of regulation to a very low value.

If you are interested in reading more on this subject, refer to the *Electronic Installation and Maintenance Book (EIMB)* series or other similar books from your technical library.

Q32. What two factors can cause output dc voltage to change?

Q33. What is the commonly used figure of merit for a power supply?

Q34. If a power supply produces 20 volts with no load and 15 volts under full load, what is the percent of regulation?

Q35. What percent of regulation would be ideal?

NEETS MODULE 6-Electronic Emission, Tubes, and Power Supplies

UNCLASSIFIED

3.2.6 Regulators

You know that the output of a power supply varies with changes in input voltage and circuit load current requirements. Because many military electronic equipments require operating voltages and currents that must remain constant, some form of regulation is necessary. The circuits that maintain power supply voltage or current outputs within specified limits, or tolerances, are called regulators. They are designated as dc voltage or dc current regulators, depending on their specific application.

Voltage regulator circuits are additions to basic power supply circuits and are made up of rectifier and filter sections. The purpose of the voltage regulator is to provide an output voltage with little or no variation. Regulator circuits sense changes in output voltages and compensate for the changes. Regulators that maintain voltages within plus or minus (\pm) 0.1 percent are quite common. The diagram in figure 3-39 clearly illustrates the purpose of the voltage regulator.

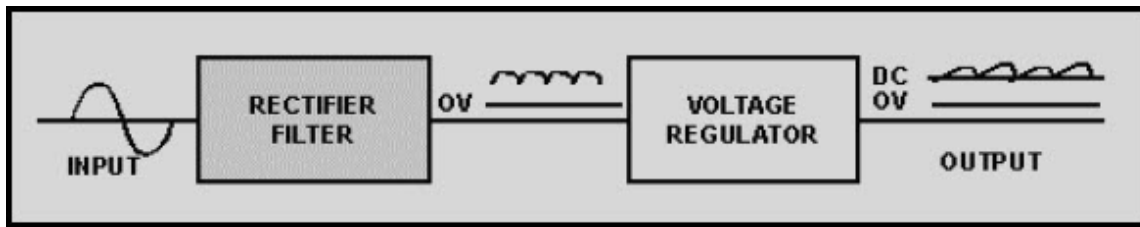

Figure 3-39 Block diagram of a power supply and regulators

There are two basic types of voltage regulators, series and shunt. Whether a voltage regulator is classified as series or shunt depends on the location or position of the regulating element(s) in relation to the circuit load resistance.

NEETS MODULE 6-Electronic Emission, Tubes, and Power Supplies
UNCLASSIFIED

Figure 3-40 illustrates the two basic types of voltage regulators. In actual practice the circuitry of regulating devices may be quite complex. We use the simplified drawings in the figure to emphasize that there are two basic types of voltage regulators. Broken lines highlight the differences between the series and shunt regulators.

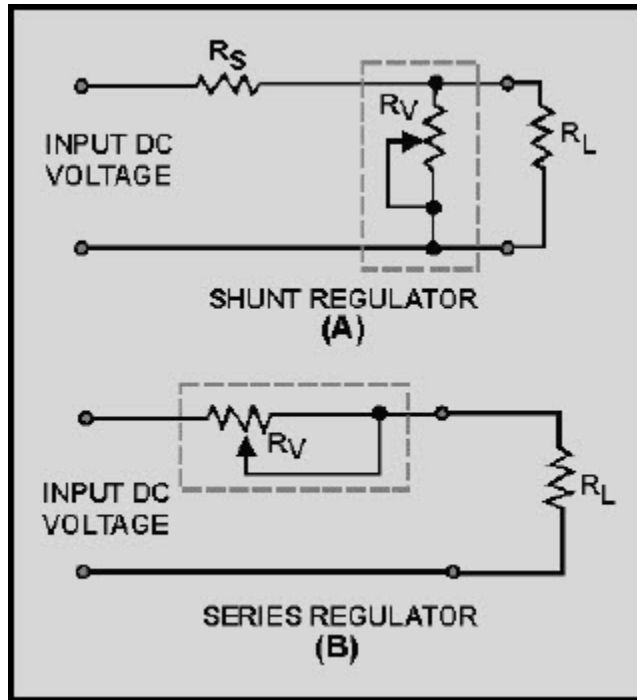

Figure 3-40 Series and shunt regulators

The schematic in view (A) is that of a shunt-type regulator. It is called a shunt-type regulator because the regulating device is connected in parallel with the load resistance. This is a characteristic of all shunt-type regulators. The schematic in view (B) is that of a series regulator. It is called a series regulator because the regulating device is connected in series with the load resistance.

NEETS MODULE 6-Electronic Emission, Tubes, and Power Supplies

UNCLASSIFIED

3.2.6.1 Series Voltage Regulator

Figure 3-41 illustrates the principle of series voltage regulation. As you study the figure, notice that the regulator is in series with the load resistance and that all current passes through the regulator. In this example, variable resistor R_v is used for regulation. Examine the circuit to determine how the regulator functions. When the input voltage increases, the output voltage also increases. However, since the voltage regulator device (R_v) senses this change, the resistance of the regulating device increases and results in a greater voltage drop through R_v . This causes the output voltage to decrease to normal or, for all practical purposes, to remain constant.

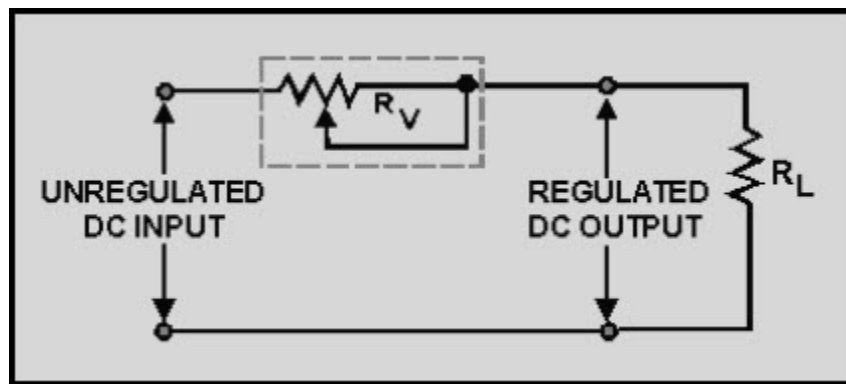

Figure 3-41 Series voltage regulator

You should be able to see that as the input voltage decreases, the resistance of the variable resistor R_v decreases almost simultaneously, thereby compensating for the voltage drop. Since there is a smaller voltage drop across R_v , the output voltage remains almost constant. Voltage fluctuations within the circuit occur in microseconds.

NEETS MODULE 6-Electronic Emission, Tubes, and Power Supplies

UNCLASSIFIED

3.2.6.2 Shunt Voltage Regulator

The diagram in figure 3-42 represents a shunter voltage regulator. Notice that variable resistor R_v is in parallel with the load resistance R_L and that fixed resistor R_s is in series with the load resistance. You already know the voltage drop across a fixed resistor remains constant unless there is a variation (increase or decrease) in the current through it.

In a shunt regulator as shown in figure 3-42, output voltage regulation is determined by the current through the parallel resistances of the regulating device (R_v), the load resistance (R_L), and the series resistor (R_s). For now, assume that the circuit in figure 3-42 is operating under normal conditions, that the input is 120 volts dc, and that the desired regulated output is 100 volts dc. For a 100-volt output to be maintained, 20 volts must be dropped across the series resistor (R_s). If you assume that the value of R_s is 2 ohms, then you must have 10 amperes of current through R_v and R_L . (Remember: $E = IR$.) If the values of the resistance of R_v and R_L are equal, then 5 amperes of current will flow through each resistance (R_v and R_L).

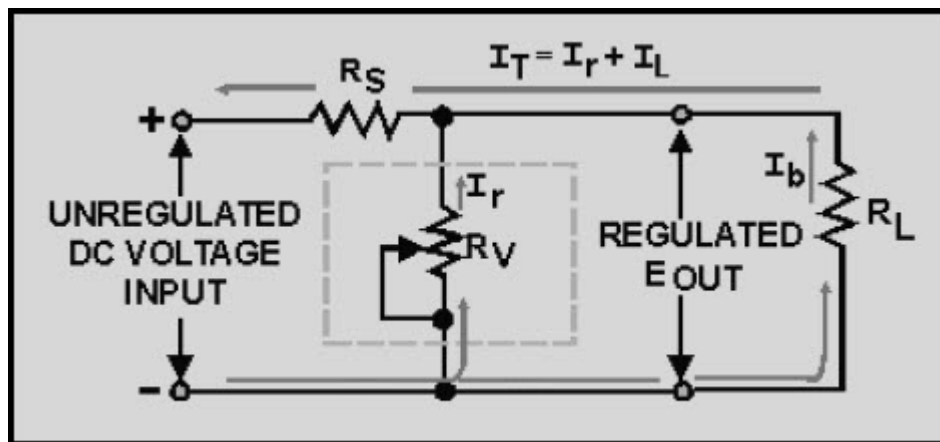

Figure 3-42 Shunt voltage regulator

Now, if the load resistance (R_L) increases, the current through R_L will decrease. For example, assume that the current through R_L is now 4 amperes and that the total current through R_s is 9 amperes. With this drop in current, the voltage drop across R_s is 18 volts; consequently, the output of the regulator has increased to 102 volts. At this time, the regulating device (R_v) decreases in resistance, and 6 amperes of current flows through this resistance (R_v). Thus, the total current through R_s is once again 10 amperes (6 amperes across R_v , 4 amperes through R_L); therefore, 20 volts will be dropped across R_s causing the output to decrease back to 100 volts.

NEETS MODULE 6-Electronic Emission, Tubes, and Power Supplies

UNCLASSIFIED

You should know by now that if the load resistance (R_L) increases, the regulating device (R_v) decreases its resistance to compensate for the change. If R_L decreases, the opposite effect will occur and R_v will increase. Now take a look at the circuit when a decrease in load resistance takes place.

When R_L decreases, the current through R_L subsequently increases to 6 amperes. This action causes a total of 11 amperes to flow through R_s which now drops 22 volts. As a result, the output is now 98 volts. However, the regulating device (R_v) senses this change and increases its resistance so that less current (4 amperes) flows through R_v . The total current again becomes 10 amperes, and the output is again 100 volts.

From these examples, you should now understand that the shunt regulator maintains the desired output voltage by sensing the current change that occurs in the parallel resistance of the circuit.

Again refer to the schematic shown in figure 3-42 and consider how the voltage regulator operates to compensate for changes in input voltages. You know, of course, that the input voltage may vary and that any variation must be compensated for by the regulating device. Consider an increase in input voltage. When this happens the resistance of R_v automatically decreases to maintain the correct voltage division between R_v and R_s . You should see, therefore, that the regulator operates in the opposite way to compensate for a decrease in input voltage.

So far we have explained the operation of voltage regulators that use variable resistors; however, this type of regulation has limitations. Obviously, the variable resistor cannot be adjusted rapidly enough to compensate for frequent fluctuations in voltage. Since input voltages fluctuate frequently and rapidly, the variable resistor is not a practical method for voltage regulation. A voltage regulator that operates continuously and automatically to regulate the output voltage without external manipulation is required.

Q36. The purpose of a voltage regulator is to provide an output voltage with little or no _____.

Q37. The two basic types of voltage regulators are _____ and _____.

Q38. When a series voltage regulator is used to control output voltages, any increase in the input voltage results in an increase/a decrease in the resistance of the regulating device.

NEETS MODULE 6-Electronic Emission, Tubes, and Power Supplies UNCLASSIFIED

Q39. A shunt type voltage regulator is connected in series/parallel with the load resistance.

3.2.6.3 Basic VR Tube Regulator Circuit

Although we covered the electrical characteristics of the VR tube in chapter 2 of this module, we now need to cover the capabilities and limitations of the VR tube itself.

Figure 3-43 shows a basic VR tube regulating circuit. The voltage produced by the source is 150 volts. The VR 90 will provide a constant 90 volts across the load resistance (R_L) if the tube is operated in the normal glow discharge region. This means that 60 volts is dropped across R_S , which is the series limiting resistance used to limit the current through the VR tube.

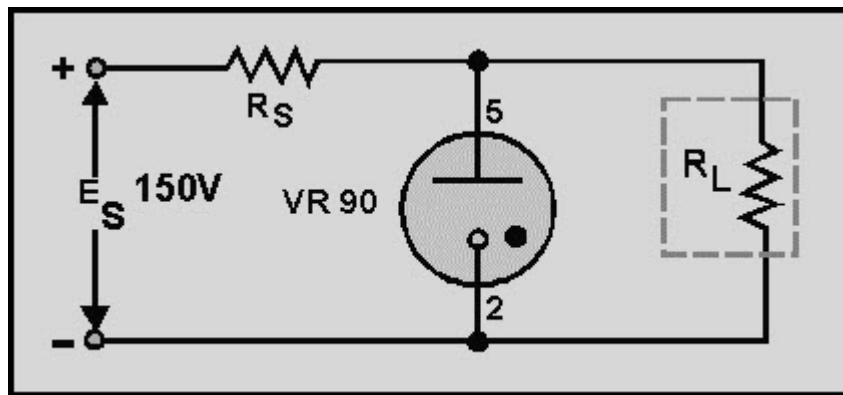

Figure 3-43 Basic VR tube regulator

Since the operating limits of a VR tube are determined by its maximum and minimum currents, circuits using such tubes should be designed to allow maximum variations in current above and below the normal point of operation. The normal point of operation, which allows maximum variation in current, must be midway between the current limits of the tube. This median current is called I_{mean} and can be calculated by the use of the following equation:

$$I_{\text{mean}} = \frac{I_{\text{max}} + I_{\text{min}}}{2}$$

NEETS MODULE 6-Electronic Emission, Tubes, and Power Supplies UNCLASSIFIED

We can determine the mean current for the VR90-40 as shown in figure 3-44 by using the following values:

$$I_{\text{mean}} = \frac{40 + 5}{2} = \frac{45}{2} = 22.5 \text{ mA}$$

To calculate the value of series dropping resistance R_S , we use the following equation:

$$R_S = \frac{\text{Source Voltage} - \text{Regulated Voltage}}{I_{\text{mean}} + I_{\text{load (average)}}$$

If the average current flowing through the load of figure 3-44 is 100 milliamperes, we can find the series dropping resistance in the following manner:

$$R_S = \frac{150 - 90}{22.5 + 100} = \frac{60 \text{ volts}}{22.5 \text{ mA}} = 490 \text{ ohms}$$

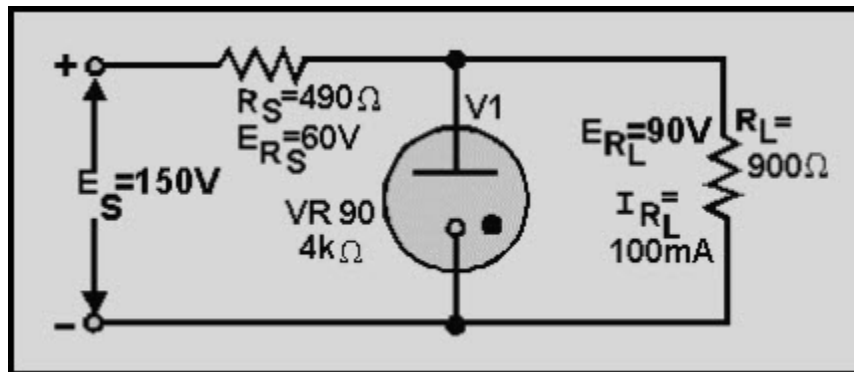

Figure 3-44 Simplified VR tube regulator

According to Ohm's law, the value of the load resistance for this circuit figure will be 900 ohms if a current of 100 milliamperes flows through R_L . The internal resistance of the VR tube can be calculated in a similar manner. With 22.5 milliamperes flowing and 90 volts dropped across the VR tube, its resistance is 4 kilohms.

NEETS MODULE 6-Electronic Emission, Tubes, and Power Supplies

UNCLASSIFIED

To determine the voltage regulation in the circuit for figure 3-44, assume a constant supply voltage of 150 volts and a variable load resistance. If the value of R_L were to decrease to 857 ohms, the load current would increase to approximately 105 milliamperes to maintain 90 volts across the load resistance. R_S must drop 60 volts. To do so requires a current of 122.5 milliamperes flowing through the series resistance. Since 105 milliamperes is now flowing through the load, the current through the VR tube must decrease from 22.5 milliamperes to 17.5 milliamperes. We will discuss the sequence of events in more detail to help you better understand how the tube current is made to vary.

The original load resistance was 900 ohms. Changes in this resistance will not occur instantaneously, but will require some time to vary from 900 ohms to a new value. As resistance of the load begins to decrease, load current begins to increase. The minute increase in load current will flow through the series resistance R_S causing a slight increase in E_{RS} . This slight increase in voltage across R_S will result in the VR tube voltage dropping slightly. This slight drop in tube voltage will cause a decrease in the ionization of the tube gas, which in turn increases the resistance of the tube. As a result, less current flows through the tube.

Note that tube current can decrease only to a value of 5 milliamperes before deionization occurs. Therefore, the load current cannot exceed 117.5 milliamperes, for beyond this value, tube current becomes less than 5 milliamperes and regulation ceases.

If load resistance were to increase, load current would decrease. This would result in the VR tube current increasing to maintain a current of 122.5 milliamperes. The VR tube current can only increase to 40 milliamperes. Beyond this value of current, the tube enters the abnormal glow region and tube voltage increases.

The upper limit of the VR tube current will occur when load current decreases to a value of 82.5 milliamperes. When load current drops below this value, the VR tube ceases to regulate the load voltage. Therefore, with a constant source voltage but variable load resistance, the limits of regulation will be reached when current in the load exceeds 117.5 milliamperes or drops below 82.5 milliamperes.

The VR tube regulator can also compensate for changes in power supply voltage. Under these conditions, the load resistance will remain constant while the power supply voltage will be variable. Refer to figure 3-44 for the following discussion.

NEETS MODULE 6-Electronic Emission, Tubes, and Power Supplies

UNCLASSIFIED

Assume that the source voltage begins to increase from an original value of 150 volts toward 155 volts. As this voltage increases, current through R_s increases from its original value of 122.5 milliamperes. Initially, this additional current is drawn from the load, causing a slight increase in load voltage. This increase in load voltage is felt across the VR tube and causes an increase in tube ionization. This decreases the internal resistance of the VR tube with a resultant increase in tube current. When source voltage reaches 155 volts, current through R_s is approximately 133 milliamperes ($R_s = 490$ ohms). Most of the additional current through R_s flows through the VR tube. As a result, approximately 33 milliamperes flows through the VR tube, maintaining the load voltage at 90 volts.

Since VR tube current decreases as source voltage decreases, tube current will drop below its lower limit of 5 milliamperes at some point. When source voltage drops below 141.4 volts, tube current will be less than 5 milliamperes and regulation will cease. The upper and lower limits of the supply voltage variations that can be allowed and still provide regulation in the circuit are 158.6 volts and 141.4 volts, respectively. Remember that tube voltage varies slightly through its operating range, but this voltage change is less than that which would exist without the use of a VR tube.

As the source voltage increases, the current through the VR tube increases. Since the upper limit of tube current is 40 milliamperes, there is a limit in the ability of the tube to regulate increasing voltage. When the supply voltage exceeds 158.6 volts, tube current will be greater than 40 milliamperes and regulation will cease.

If the source voltage decreases from 150 volts to 145 volts, only 55 volts must be dropped across the 490-ohm series resistance (R_s) to maintain the load voltage at 90 volts. Current through R_s for a 55 volt drop is 112 milliamperes. Since load current is 100 milliamperes, the remaining 12 milliamperes must flow through the VR tube. This represents a decrease in the ionization level of the VR tube, with a resultant increase in tube resistance. Under these conditions, 90 volts will be maintained across the load resistance.

NEETS MODULE 6-Electronic Emission, Tubes, and Power Supplies

UNCLASSIFIED

3.2.6.3.1 VR Tubes Connected in Series

In applications where a regulated voltage in excess of the maximum rating of one tube is required, two or more tubes may be placed in series as shown in figure 3-45.

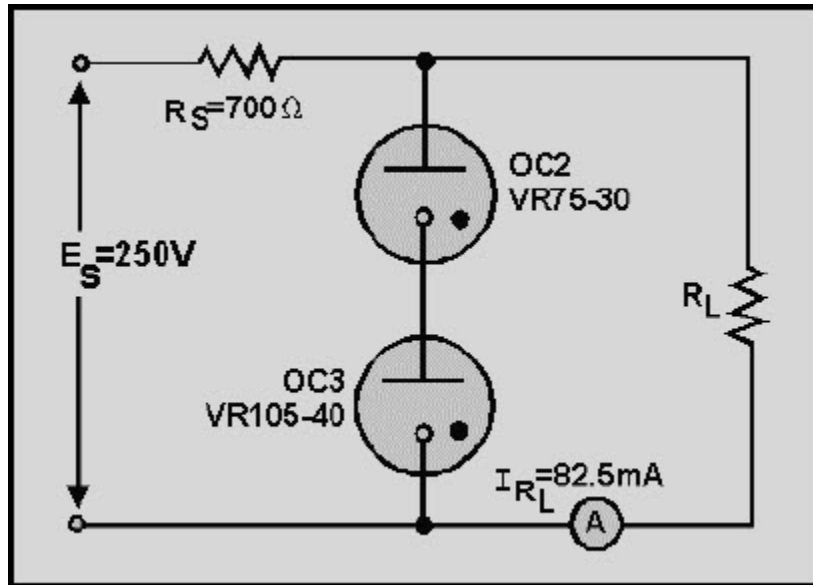

Figure 3-45 VR tubes as voltage dividers

In the figure, a VR75-30 and a VR105-40 are shown connected in series. The source voltage is 250 volts, and 82.5 milliamperes flows through the load resistance. Since current through the two VR tubes is common, the limits of regulation are determined by the tube having the smaller current limitations. (In this case, the VR 75-30). In computing I_{mean} for this circuit, I_{max} and I_{min} will be 30 milliamperes and 5 milliamperes, respectively. Therefore, the mean current will be 17.5 milliamperes.

The value of R_S in the figure can be computed using the source voltage of 250 volts and the total current through R_S (load current + I_{mean}). Using these values, $R_S = 700$ ohms. Note that the regulated voltage to the load is 180 volts. This provides a regulated voltage greater than would be possible using either VR tube by itself.

NEETS MODULE 6-Electronic Emission, Tubes, and Power Supplies UNCLASSIFIED

Another advantage of using VR tubes in series is illustrated in figure 3-46. In this circuit, several values of regulated voltages are obtained from a single power supply.

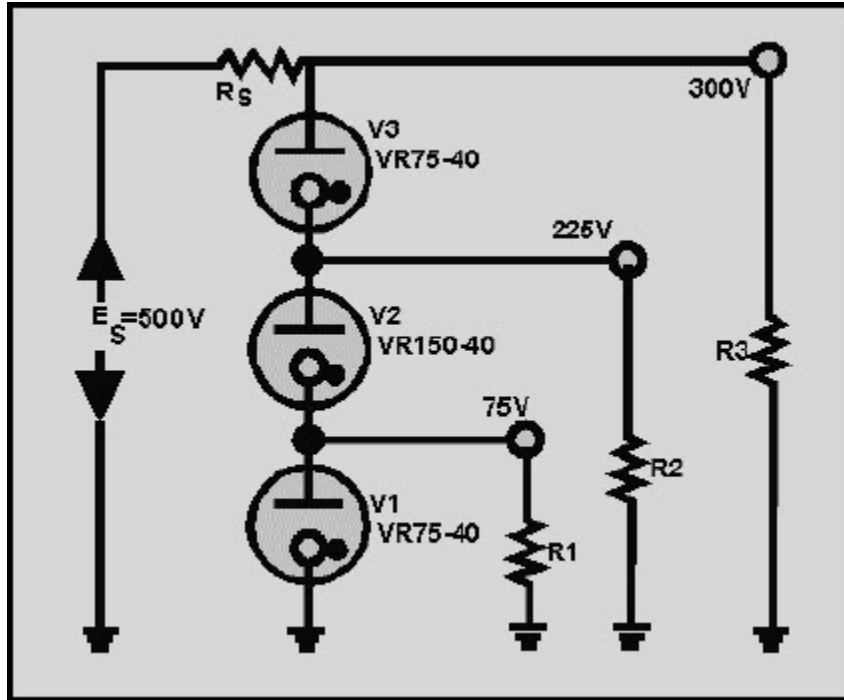

Figure 3-46 VR tubes as voltage dividers

The current flowing through V_2 in the figure is a combination of the current through R_1 and the current through V_1 . The current through V_3 , on the other hand, is the sum of the currents through V_2 and R_2 . Since V_3 has more current flowing through it than any of the other VR tubes, it places or determines the limit on the maximum current in the VR tube circuit. Since the maximum rating of V_3 is 40 milliamperes, the currents through R_1 and R_2 must be limited to only a few milliamperes, or the rating of V_3 will be exceeded and regulation will cease.

The obvious advantage in using VR tubes in series is to provide several regulated voltages from a single power supply. The primary disadvantage is in the current limitations. Since it is impossible to have all VR tubes operating about their mean current values, this limits the ability of the circuit to regulate over wide ranges of variations in load resistance or source voltage.

NEETS MODULE 6-Electronic Emission, Tubes, and Power Supplies

UNCLASSIFIED

3.2.6.3.2 VR Tubes Connected in Parallel

One might expect that connecting VR tubes in parallel as shown in figure 3-47 would increase the current handling capacity of the network. Although this is true for some gas-filled tubes, it is not true for VR tubes. In figure 3-47, two VR tubes are constructed in exactly the same way. The only difference will be a slight variation in their ionization potential. For the purpose of this discussion, VR tube VR1 will have a lower ionization potential than VR2. The potential that must be reached before a VR tube ionizes is considerably higher than its normal operating voltage.

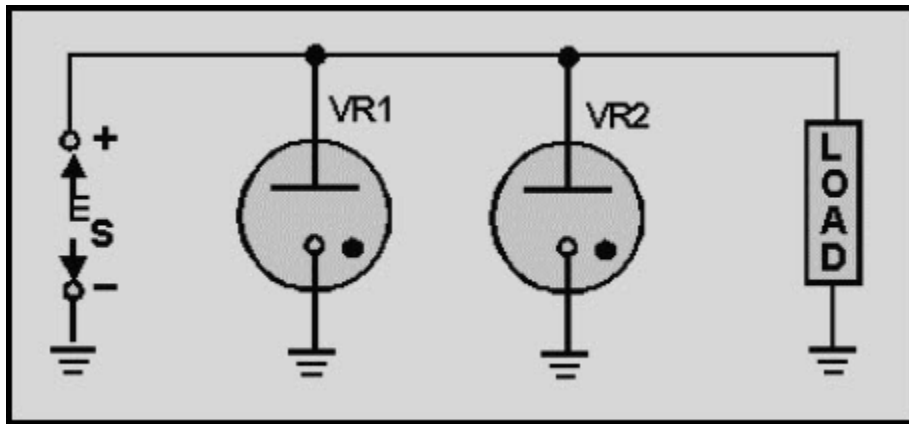

Figure 3-47 VR tubes connected in parallel

When voltage is applied to the circuit of figure 3-47, as soon as the correct potential is reached, VR1 begins to conduct and the potential across it decreases to its operating voltage. The potential across VR2 never becomes high enough to cause it to ionize. Therefore, placing the VR tubes in parallel accomplishes no useful purpose. When greater current handling capacity and better regulation are desired, electronic (vacuum tube) regulator circuits are used.

Several conditions may either indicate or cause problems with a VR tube regulator. Initially, you can get some indication of the trouble associated with a gas-tube regulator circuit by visually inspecting it to determine the presence of the characteristic glow from the ionized gas within the tube. When current through the tube is near its maximum rating, the tube is highly ionized. When the current is near its minimum rating, the tube is lightly ionized. Therefore, the intensity of the gaseous discharge within the tube is an indication of tube conduction. If the tube is not ionized, however, this does not necessarily mean that the tube is defective. The same indication (lack of characteristic glow) may also result from the following conditions: the series resistor (R_s) has increased in value, the dc input voltage (E_s) is below normal, the load current is below normal, or the load current is excessive.

NEETS MODULE 6-Electronic Emission, Tubes, and Power Supplies

UNCLASSIFIED

You therefore need to make dc voltage measurements at the input and output terminals of the voltage regulator circuit to determine whether the problem is inside the regulator circuit or outside of it.

You can check value of the series resistor (R_s) by using ohmmeter measurements to determine whether any change in resistance has occurred. If the maximum current rating of the regulator tube is exceeded for a considerable length of time, the tube may be damaged and lose its regulation characteristics; therefore, you can suspect the regulator tube itself as a possible source of trouble.

Although VR tubes are used extensively in electronic equipment, there are circuits that require a greater degree of regulation than a VR tube can provide. For these circuits, an electron tube voltage regulator is used.

3.2.6.4 Electron Tube Voltage Regulator

An electron tube may be considered a variable resistance. When the tube is passing a direct current, this resistance is simply the plate-to-cathode voltage divided by the current through the tube and is called the dc plate resistance (R_p). For a given plate voltage, the value of R_p depends upon the tube current, and the tube current depends upon the grid bias.

Refer to figure 3-48, view (A). The resistance of V1 is established initially by the bias on the tube. Assume that the voltage across the load is at the desired value. Then the cathode is positive with respect to ground by some voltage (E_L). The grid can be made positive relative to ground by a voltage (E_2) that is less than E_1 . The potentiometer R2 is adjusted until the bias (grid-to-cathode voltage), which is $E_2 - E_1$, is sufficient to allow V1 to pass a current equal to the desired load current. With this bias, the resistance of V1 is established at the proper value to reduce the rectifier output voltage to the desired load voltage.

NEETS MODULE 6-Electronic Emission, Tubes, and Power Supplies
UNCLASSIFIED

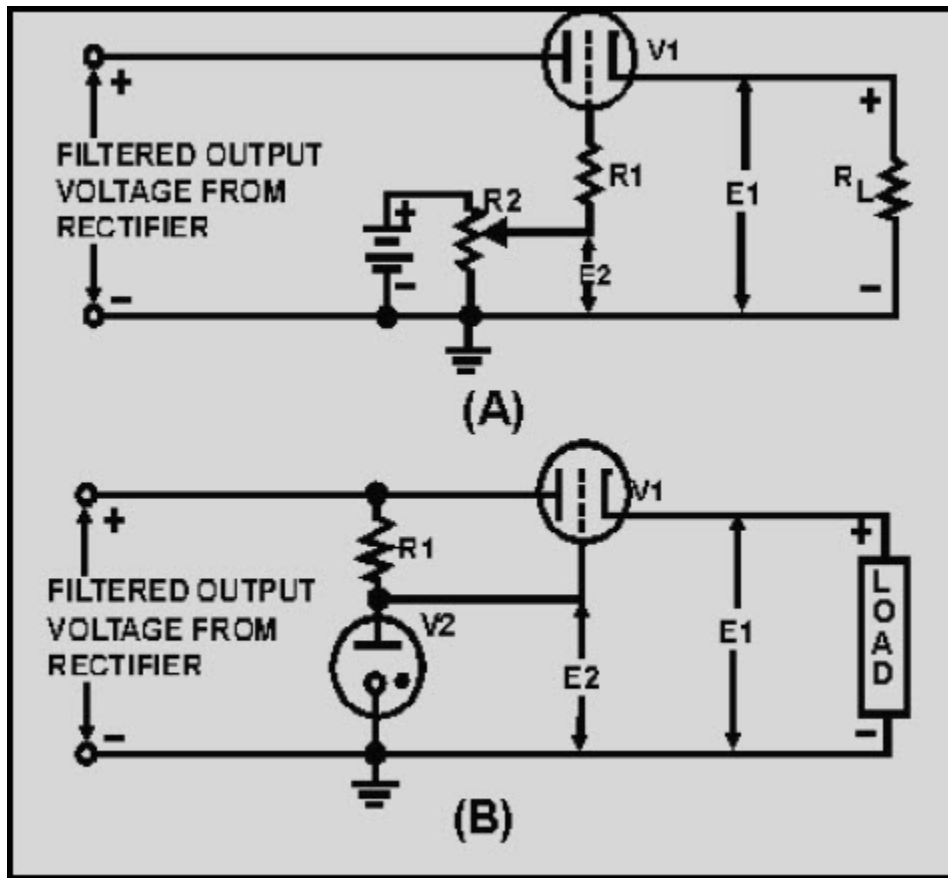

Figure 3-48 Electron tube voltage regulator using a battery for the fixed bias

If the rectifier output voltage increases, the voltage at the cathode of V1 tends to increase. As E1 increases, the negative bias on the tube increases and the plate resistance of the tube becomes greater. Consequently, the voltage drop across V1 increases with the rise in input voltage. If the circuit is designed properly, the increased voltage drop across V1 is approximately equal to the increase in voltage at the input. Thus the load voltage remains essentially constant.

The resistor (R1) is used to limit the grid current. This is necessary in this particular circuit because the battery is not disconnected when the power is turned off. However, the battery can be eliminated from the circuit by the use of a glow tube (V2), as shown in view (B) of the figure, to supply a fixed bias for the grid of the tube. The action of the circuit in view (B) is the same as the action of the circuit in view (A). The output voltage of the simple voltage regulators shown in the figure cannot remain absolutely constant. As the rectifier output voltage increases, the voltages on the cathode of V1 must rise slightly if the regulator is to function.

NEETS MODULE 6-Electronic Emission, Tubes, and Power Supplies

UNCLASSIFIED

The voltage regulators shown in the figure compensate not only for changes in the output voltage from the rectifier, but also for changes in the load. For example, in view (B) if the load resistance decreases, the load current will increase. The load voltage will tend to fall because of the increased drop across V1. The decrease in load voltage is accompanied by a decrease in bias voltage on V1. The bias voltage on V1 is equal to $E_1 - E_2$. Thus the effective resistance of V1 is reduced at the same time the load current is increased. The IR drop across V1 increases only a slight amount because R decreases about as much as I increases. Therefore, the tendency for the load voltage to drop when the load is increased is checked by the decrease in resistance of the series triode.

Q40. In an electron tube regulator, the electron tube replaces what component?

3.2.7 Current Regulation

Before we go to the next section, there is one type of regulation that we should discuss-current regulation. In most power supplies, current is not regulated directly. Fuses and other circuit protection devices are used to set an upper limit on the amount of current that can flow in a power supply. Once this limit is exceeded, the fuse simply opens and the power supply is deenergized. Beyond this, current is usually left unregulated because the load will draw from the power supply only the amount of current that it needs. Decreases and increases in the power supply voltage caused by the variations in load current are usually controlled by the voltage regulator.

NEETS MODULE 6-Electronic Emission, Tubes, and Power Supplies UNCLASSIFIED

3.2.7.1 The Amperite Regulator

There are some cases in which current must be regulated or kept at a relatively constant value. The best example of this is the filament supply of a power transformer located in a power supply that is designed to supply filament power to many tubes. You can see this in view (A) of figure 3-49, which is a portion of a power supply designed to supply 50 vacuum tubes with both plate and filament voltages. Under normal conditions, circuit current will not exceed 2.5 amperes. For this reason, the power supply has been fused at 3 amperes. Because you are only interested in current regulation at this time, only the portion of the power supply that deals with current regulation is shown; namely, the power transformer and four of the 50 parallel connected vacuum-tube filaments. At operating temperatures, the resistance of each filament is 1 kilohm. Because the filaments are connected in parallel, the total filament resistance at operating temperature is 20 ohms. Ohm's law,

$$I = \frac{E}{R}$$

tells you that the filaments draw .315 amperes. You should know from your previous study that as conductors are heated, their resistance increases. Therefore, the cold resistance of the filaments is considerably lower than the hot resistance. In this case, assume 100 ohms per filament. The total resistance of the 50 parallel filaments is then 2 ohms when the power supply is first energized, and the filaments draw 3.15 amperes of current. If the current for the rest of the power supply is added to the filament current, the surge current will cause the power supply to draw 5 amperes when it is first energized. Unfortunately, the power supply is fused at 3 amperes. Under these conditions, it would be impossible to keep the power supply on the line long enough to get the filaments up to operating temperature.

There are three possible solutions to this problem. The first is simply to fuse the power supply at 5 amperes, but this could allow excessive current to flow in the power supply. Another solution is to use a slow-blow fuse. Unfortunately, the duration of the current surge may exceed the time limit that a slow-blow fuse can handle. Therefore, current regulation is the best solution to this problem.

Because of its quick-heating ability, the amperite tube is ideal as a current regulator. The amperite regulator is nothing more than an iron wire enclosed in a hydrogen-filled envelope. Because of its construction, the iron filament will heat quickly when current is applied to it.

NEETS MODULE 6-Electronic Emission, Tubes, and Power Supplies UNCLASSIFIED

View (B) of figure 3-49 shows the amperite regulator connected in series with the filaments of the load. When the power supply is first energized, the iron wire of the amperite gets hot quickly and presents a large resistance connected in series with the 2 ohms of filament resistance. As a result, most of the voltage is dropped across the amperite. Because of the large resistance of the amperite regulator, current in the circuit is held to an acceptable level in accordance with Ohm's law:

$$I = \frac{E}{R}$$

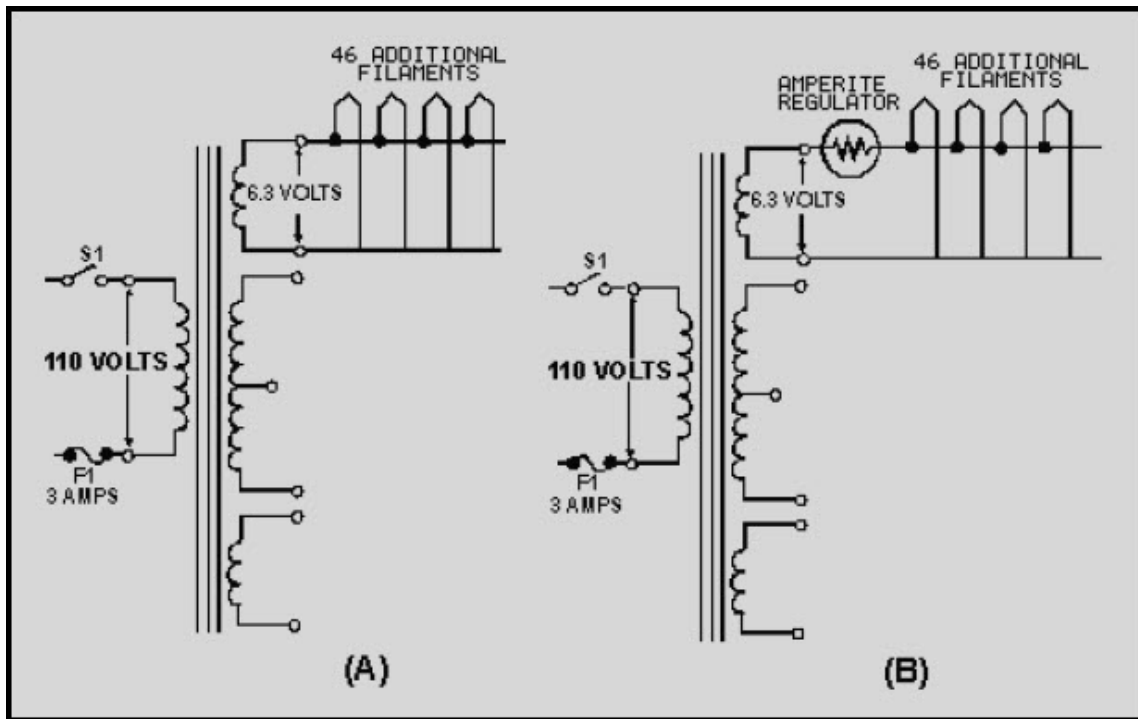

Figure 3-49 Amperite regulator

As the filaments warm up, their resistance increases, which causes circuit current to decrease. The decreasing circuit current allows the iron wire of the amperite to cool. As it cools, its resistance decreases until it reaches the approximate resistance of the circuit wiring. You might think that decreasing the resistance of the amperite would allow circuit current to increase again, but this does not happen. As the iron wire of the amperite cools and its resistance decreases, the resistance of the warming tube filaments increases. Throughout the entire heating cycle of the filaments, the total resistance of the series circuit, consisting of the amperite and tube filaments, remains fairly constant. When power is first applied, most of the resistance is in the amperite. Therefore, most of the voltage is dropped across the resistance of the amperite.

NEETS MODULE 6-Electronic Emission, Tubes, and Power Supplies

UNCLASSIFIED

Halfway through the cycle, the resistance of the amperite and the resistance of the filaments are approximately equal, and the voltage drops across the two series elements are equal. Finally, when the filaments have reached their operating temperature, most of the resistance is in the filaments of the tube. Therefore, most of the voltage is dropped across the tube filaments.

The important thing to note is that the total circuit resistance remains approximately the same throughout the heating cycle. As the cycle progresses, the resistance of the amperite decreases as the resistance of the tube filaments increases. Because resistance and voltage (6.3 volts) remain constant, current remains constant, except for the slight surge in the beginning of the heating cycle, which is necessary to heat up the iron wire of the amperite.

Now that we have discussed the different types of regulators, you should be able to see that there are many variables that affect good regulation.

Although you may not be required to design regulators, you will be required to maintain them because your electronic equipment depends upon good regulation to operate properly.

Up to this point we have discussed only the individual sections of the electron tube power supply. In the next section, we will discuss the techniques of troubleshooting these individual sections and the total power supply.

Q41. What is the purpose of the amperite regulator?

Q42. As the tube filaments in the load heat up, will the circuit current increase or decrease?

NEETS MODULE 6-Electronic Emission, Tubes, and Power Supplies

UNCLASSIFIED

3.3 TROUBLESHOOTING POWER SUPPLIES

Whenever you work with electricity, you **must** follow all the appropriate safety precautions. In the front of all electronic technical manuals, you will always find a section on safety precautions. You should also find posted on each piece of equipment a sign listing the specific precautions for that equipment. One hazardous area that is sometimes overlooked, especially on board ship, is grounding of equipment. By grounding the return side of the power transformer to the metal chassis, manufacturers can wire the cathodes of the tubes in both the power supply and the load being supplied by the power supply directly to the metal chassis. This eliminates the necessity of wiring each tube directly to the return side of the transformer, saving wire, and reducing the cost of building the equipment. While this solves one of the problems of the manufacturer, it creates a problem for you, the technician. Unless the chassis is physically grounded to the ship's ground (the hull), the chassis can be charged (or can float) several hundred volts above ship's ground. If you come in contact with the metal chassis at the same time you are in contact with the ship's hull, the current from the chassis can use your body as a low resistance path back to the ship's ac generators. At best this can be an unpleasant experience; at worst it can be fatal. For this reason Navy electronic equipment is always grounded to the ship's hull, and approved rubber mats are required in all spaces where electronic equipment is present. Therefore, before you start to work on any electronic or electrical equipment ALWAYS ENSURE THAT THE EQUIPMENT AND ANY TEST EQUIPMENT YOU ARE USING IS PROPERLY GROUNDED AND THAT THE RUBBER MAT YOU ARE STANDING ON IS IN GOOD CONDITION. As long as you follow these simple rules, you should be able to avoid the possibility of becoming an electrical conductor.

NEETS MODULE 6-Electronic Emission, Tubes, and Power Supplies

UNCLASSIFIED

3.3.1 Testing

There are two widely used checks in testing electronic equipment. The first is the **VISUAL CHECK**. Do not underestimate the importance of this check. Many technicians find defects right away simply by looking for them. A visual check does not take long; in fact you should be able to see the problem in about 2 minutes if it is the kind of problem that can be seen. You should learn the following procedure. You will find yourself using it quite often, as it is good not only for power supplies but also for any other type of electronic equipment you may be troubleshooting.

1. BEFORE YOU PLUG IN THE EQUIPMENT, LOOK FOR:

- a. LOOSE TUBES - A tube that is not properly seated in its socket may not be making proper contact with the rest of the circuit. It may very well be the source of your problem. Push the tube completely into place.
- b. SHORTS - Examine any terminal or connection that is close to the chassis or to any other terminal for the possibility of a short. A short in any part of the power supply can cause considerable damage. Look for and remove any stray drops of solder, bits of wire, nuts, or screws. It sometimes helps to shake the chassis and listen for any tell-tale rattles. Remember to correct any problem that may cause a short circuit. If it is not causing trouble now, it may cause problems in the future.
- c. DISCOLORED OR LEAKING TRANSFORMER - This is a sure sign that there is a short somewhere. Locate it. If the equipment has a fuse, find out why the fuse did not blow; too large a size may have been installed, or there may be a short across the fuse holder.
- d. LOOSE, BROKEN, OR CORRODED CONNECTIONS - Any connection that is not in good condition is a trouble spot. If it is not causing problems now, it probably will in the future. Fix it.
- e. DAMAGED RESISTORS OR CAPACITORS - A resistor that is discolored or charred has been subjected to an overload. An electrolytic capacitor will show a whitish deposit at the seal around the terminals. Check for a short whenever you notice a damaged resistor or capacitor. If there is no short, the trouble may be that the power supply has been overloaded in some way. Make a note to replace the part after signal tracing. There is no sense in risking a new part until you have located the trouble.

NEETS MODULE 6-Electronic Emission, Tubes, and Power Supplies UNCLASSIFIED

2. PLUG IN THE POWER SUPPLY AND LOOK FOR:

a. SMOKING PARTS - If any part smokes or if you hear any boiling or sputtering sounds, pull the plug immediately. There is a short circuit somewhere that you have missed in your first inspection. Use an ohmmeter to check the part again; begin in neighborhood of the smoking part.

b. COLD TUBES - After allowing the equipment about two minutes for warm-up, touch all the tubes. If a tube is cold, it is either burned out or there is a break in the heater connections and the tube is not receiving proper heater voltage. Remove the tube and connect an ohmmeter across the heater terminals to see if the filament is open (reads almost infinite resistance). If the filament reads open, it is burned out. Replace the bad tube with a good one. If the filament reads a low resistance, this indicates that the filament is all right. Use an ac voltmeter to find the break between the filament and the output of the transformer.

c. SPARKING - Tap or shake the chassis. If you see or hear sparking, you have located a loose connection or a short. Check and repair the problem.

If you locate and repair any of the defects listed under the visual check, make a note of what you find and what you do to correct it. It is quite probable you have found the trouble. However, a good technician takes nothing for granted. You must prove to yourself that the equipment is operating properly and that no other troubles exist.

If you find none of the defects listed under the visual check, go ahead with the signal tracing procedure. The trouble is probably of such a nature that you cannot see it directly with your eye-you must see it through the eye of the oscilloscope.

The second type of testing is signal tracing. Tracing the ac signal through the equipment is the most rapid method of locating a trouble that you cannot find by a visual check. It also serves as a check on any repairs you may have made. The idea is to trace the ac voltage from the transformer, to see it change to pulsating dc at the rectifier tube filament, and then to see the pulsations smoothed out by the filter. The point where the signal stops or becomes distorted is the place to look for the trouble.

Before you begin signal tracing, it is a good idea to measure the dc voltage. The dc output voltage should be in the neighborhood of 340 volts. If you have no dc output voltage, you should look for an open or a short in your signal tracing. If you have a low dc voltage, you should look for a defective part and keep your eyes open for the place where the signal becomes distorted.

Signal tracing is done by observing the waveform at the input and output of each part of a circuit. It is the method used to localize trouble in a circuit.

NEETS MODULE 6-Electronic Emission, Tubes, and Power Supplies UNCLASSIFIED

Let's review what each part of a good power supply does to the signal, as shown in figure 3-50. The ac voltage is brought in from the power line through the line cord. This voltage is connected to the primary of the transformer through the **ON-OFF** switch (S1). At the secondary winding of the transformer (points 1 and 2), the scope shows you a picture of the stepped-up voltage developed across each half of the secondary winding - the picture is that of a complete sine wave. Each of the two stepped-up voltages is connected between ground and one of the two plates of the rectifier tube. At the two rectifier plates (points 4 and 5) there is still no change in the shape of the stepped-up voltage the scope picture still shows a complete sine wave.

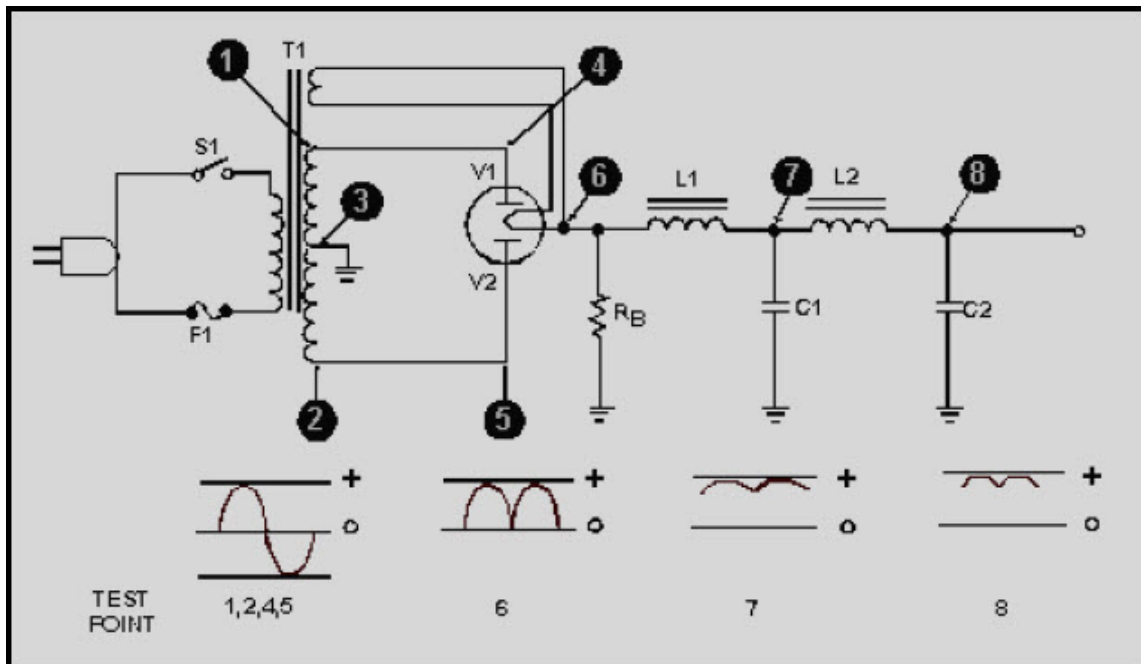

Figure 3-50 Complete power supply (without regulator)

However, when you look at the scope pattern for point 6 (the voltage at the rectifier heater), you see the wave shape for pulsating direct current. This pulsating dc is fed through the first choke (L1) and filter capacitor (C1), which remove a large part of the ripple or "hum," as shown by the waveform for point 7. Finally, the dc voltage is fed through the second choke (L2) and filter capacitor (C2), which remove nearly all of the remaining ripple. See the waveform for point 8, which shows almost no visible ripple. You now have almost pure dc.

No matter what power supplies you may encounter in the future, they all do the same thing - they change ac voltage into dc voltage.

NEETS MODULE 6-Electronic Emission, Tubes, and Power Supplies

UNCLASSIFIED

3.3.2 Component Problems

The following paragraphs will give you an indication of troubles that occur with many different electronic circuit components.

3.3.2.1 Tube Troubles

The symptoms of tube trouble will vary with every type of circuit and each type of tube. However, the problems that can develop with a tube are common to every tube. Here are the five possible tube troubles that you should keep in mind. The meaning of each trouble will be clear by the time you end your study of vacuum tubes, even though you may not quite understand them now.

1. The filament, after long service, may be unable to emit as many electrons as are required for proper operation.
2. The filament may burn out.
3. A tube element-the plate, for instance-may break its connection with the tube base pin.
4. Two elements, such as filament and plate, may short together.
5. The tube may become gassy.

The symptoms you will come across in signal tracing will be many and varied. You will need to combine your "know-how" of the circuit and your knowledge of these five possible tube troubles to determine if the tube could in some way be causing the symptoms. If you suspect the tube of causing trouble, either try another tube in its place or check it on a tube tester. But remember, the final check of whether or not the old tube was bad is whether or not the equipment works properly when a good tube is put in its place. Therefore, putting in a good tube and then trying out the equipment is the best check.

NEETS MODULE 6-Electronic Emission, Tubes, and Power Supplies UNCLASSIFIED

3.3.2.2 Transformer and Choke Troubles

As you should know by now, the transformer and choke are quite similar in construction. Therefore, it is no coincidence that the basic troubles they can develop are the same.

1. A winding can open.
2. Two or more turns of one winding can short together.
3. A winding can short to the casing, which is usually grounded.
4. Two windings can short together. This trouble is possible, of course, only in transformers.

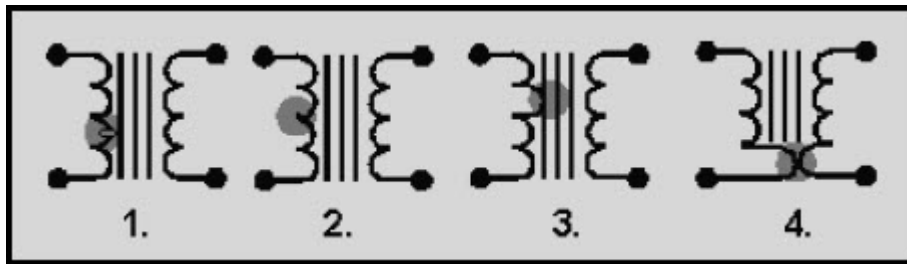

As with the tube, the symptoms of these troubles will vary with the type of circuit. However, when you have decided that one of these four possible troubles could be causing the symptoms, there are definite steps to take. If you surmise that there is an open winding or windings shorted together or to ground, an ohmmeter continuity check will locate the trouble. If the turns of a winding are shorted together, you may not be able to detect a difference in winding resistance. Therefore, you need to connect a good transformer in the place of the old one and see if the symptoms are eliminated; but keep in mind that transformers are difficult to replace. Make absolutely sure that the trouble is not elsewhere in the circuit before you change the transformer.

Occasionally, shorts will appear only when operating voltages are applied to the transformer. In this case you might find the trouble with a megger - an instrument that applies a high voltage as it reads resistance.

NEETS MODULE 6-Electronic Emission, Tubes, and Power Supplies

UNCLASSIFIED

3.3.2.3 Capacitor and Resistor Troubles

Only two things can happen to a capacitor:

1. It may open up, removing itself completely from the circuit.
2. It may develop an internal short circuit. This means that it begins to pass current as though it were a resistor or a direct short.



You can check a capacitor you suspect of being open by disconnecting it from the circuit and checking it with a capacitor analyzer. You can check a capacitor you suspect of being leaky with an ohmmeter; if it reads less than 500 kilohms, it is more than likely bad. However, capacitor troubles are difficult to find since they may appear intermittently or only under operating voltages. Therefore, the best check for a faulty capacitor is to replace it with one you know to be good. If this restores proper operation, the fault was in the capacitor.

Resistor troubles are the simplest; but like the rest, you must keep them in mind.

1. A resistor can open up.
2. A resistor can increase in value.
3. A resistor can decrease in value.

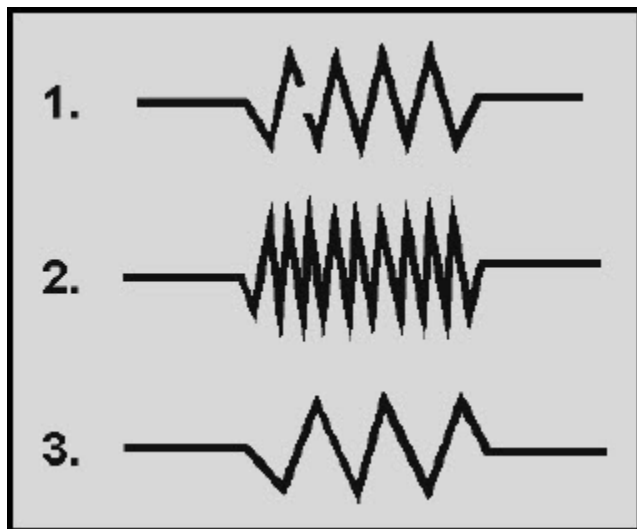

NEETS MODULE 6-Electronic Emission, Tubes, and Power Supplies

UNCLASSIFIED

You already know how to check possible resistor troubles. Just use an ohmmeter after making sure no parallel circuit is connected across the resistor you wish to measure. When you know a parallel circuit is connected across the resistor or when you are in doubt, disconnect one end of the resistor before measuring it. The ohmmeter check will usually be adequate. However, never forget that intermittent troubles may develop in resistors as well as in any other electronic parts. Also remember that the final proof that a resistor is bad is when you replace it with another resistor and the equipment operates satisfactorily.

Although you may observe problems that we have not covered specifically in this chapter, you should have gained enough knowledge to localize and repair any problem that may occur.

Q43. What is the most important thing to remember when troubleshooting?

Q44. What is the main reason for grounding the return side of the transformer to the chassis?

Q45. What are two types of checks used in troubleshooting power supplies?

NEETS MODULE 6-Electronic Emission, Tubes, and Power Supplies

UNCLASSIFIED

3.4 SUMMARY

In this chapter, we have presented you a basic description of the theory and operation of a basic power supply and its components. The following summary should enhance your understanding of power supplies.

POWER SUPPLIES are electronic circuits designed to convert ac to dc at any desired level. Almost all power supplies are composed of four sections: transformer, rectifier, filter, and regulator.

The **POWER TRANSFORMER** is the input transformer for the power supply. In addition to the high voltage, the power transformer also supplies filament voltage.

The **RECTIFIER** is the section of the power supply that contains the secondary windings of the power transformer and the rectifier circuit. The rectifier uses the ability of a diode to conduct during one half cycle of ac to convert ac to dc.

HALF-WAVE RECTIFIERS give an output on only one half cycle of the input ac. For this reason, the pulses of dc are separated by a period of one half cycle of zero potential voltage.

FULL-WAVE RECTIFIERS conduct on both halves of the input ac cycles. As a result, the dc pulses are not separated from each other. A characteristic of full-wave rectifiers is the use of a center-tapped, high-voltage secondary. Because of the center tap, the output of the rectifier is limited to one-half of the input voltage of the high-voltage secondary.

BRIDGE RECTIFIERS are full-wave rectifiers that do not use a center-tapped, high-voltage secondary. Because of this their dc output voltage is equal to the input voltage from the high-voltage secondary of the power transformer. Bridge rectifiers use four diodes connected in a bridge network. Tubes conduct in diagonal pairs to give a full-wave pulsating dc output.

FILTER CIRCUITS are designed to smooth, or filter, the ripple voltage present on the pulsating dc output of the rectifier. This is done by an electrical device that has the ability to store energy and to release the stored energy.

CAPACITANCE FILTERS are nothing more than large capacitors placed across the output of the rectifier section. Because of the large size of the capacitors, fast charge paths, and slow discharge paths, the capacitor will charge to average value, which will keep the pulsating dc output from reaching zero volts.

NEETS MODULE 6-Electronic Emission, Tubes, and Power Supplies

UNCLASSIFIED

INDUCTOR FILTERS use an inductor called a choke to filter the pulsating dc input. Because of the impedance offered to circuit current, the output of the filter is at a lower amplitude than the input.

PI-TYPE FILTERS use both capacitive and inductive filters connected in a pi-type configuration. Because of the combination of filtering devices, the ability of the pi filter to remove ripple voltage is superior to that of either the capacitance or inductance filter.

VOLTAGE REGULATORS are circuits designed to maintain the output of power supplies at a constant amplitude despite variations of the ac source voltage or changes of the resistance of the load. This is done by creating a voltage divider of a resistive element in the regulator and the resistance of the load. Regulation is achieved by varying the resistance of the resistive element in the regulator.

A **SERIES REGULATOR** uses a variable resistance in series with the load. Regulation is achieved by varying this resistance either to increase or decrease the voltage drop across the resistive element of the regulator. Characteristically, the resistance of the variable resistance moves in the same direction as the load. When the resistance of the load increases, the variable resistance of the regulator increases; when load resistance decreases, the variable resistance of the regulator decreases.

SHUNT REGULATORS use a variable resistance placed in parallel with the load. Regulation is achieved by keeping the resistance of the load constant. Characteristically, the resistance of the shunt moves in the opposite direction of the resistance of the load.

VR-TUBE REGULATORS are shunt regulators that use a cold cathode as a variable resistance in parallel with the load. Because of their ability to maintain a constant voltage potential between their plates and cathode, glow tubes can be connected in series to regulate any voltage. Additionally, glow tubes can be used to deliver different voltages to different loads.

SIMPLE ELECTRON TUBE REGULATORS use the dc plate resistance of a triode as a variable resistance in series with the load. The resistance of the vacuum tube is varied by changing the amount of conduction of the tube. This is done by holding the control grid voltage at a constant level and allowing the cathode voltage to vary with the output voltage.

The **AMPERITE VOLTAGE REGULATOR** or **BALLAST TUBE** is normally used to control current surges. This is done by heating an iron wire in a hydrogen-filled envelope. The hot iron will present a large resistance to current flow.

NEETS MODULE 6-Electronic Emission, Tubes, and Power Supplies
UNCLASSIFIED

ANSWERS TO QUESTIONS Q1. THROUGH Q45.

A1. Transformer, rectifier, filter, regulator.

A2. To maintain a constant voltage to the load.

A3. It couples the power supply to the ac line voltage, isolates the ac line voltage from the load, and steps this voltage up or down to the desired level.

A4. Filament voltage to the electron tubes.

A5. Provides capability of developing two high-voltage outputs.

A6. Positive.

A7. Cutoff.

A8. Pulsating dc.

A9. Series.

A10. 60 hertz.

A11. $E_{avg} = 0.318 \times E_{max}$.

A12. 120 hertz.

A13. 63.6 volts.

A14. The peak voltage is half that of a half-wave rectifier.

A15. The bridge rectifier can produce double the voltage with the same size transformer.

A16. Decrease-Capacitance is inversely proportional to X_c .

A17. Capacitor.

A18. Parallel.

A19. High.

A20. Increase.

A21. Value of capacitance and load resistance.

NEETS MODULE 6-Electronic Emission, Tubes, and Power Supplies
UNCLASSIFIED

A22. *Good.*

A23. *Yes.*

A24. *Counter electro-motive force of the inductor.*

A25. *1 to 20 henries.*

A26. *Decrease.*

A27. *Small.*

A28. *Expense.*

A29. *When ripple must be held at an absolute minimum.*

A30. *LC capacitor-input filter.*

A31. *Cost of the inductor and size of the inductor.*

A32. *Ac line voltage and a change in load resistance.*

A33. *Percent of regulator.*

A34. *33.33%*

A35. *0%.*

A36. *Variation.*

A37. *Series and shunt.*

A38. *Increase.*

A39. *Parallel.*

A40. *Variable resistor.*

A41. *Current regulation.*

A42. *Decrease.*

A43. *Safety precautions.*

NEETS MODULE 6-Electronic Emission, Tubes, and Power Supplies
UNCLASSIFIED

A44. Reduce the cost of manufacturing equipment.

A45. Visual and signal tracing.

NEETS MODULE 6-Electronic Emission, Tubes, and Power Supplies
UNCLASSIFIED

APPENDIX A

Glossary

ACCELERATING ANODE - An electrode charged several thousand volts positive and used to accelerate electrons toward the front of a cathode-ray tube.

ACORN TUBE - A very small tube with closely spaced electrodes and no base. The tube is connected to its circuits by short wire pins that are sealed in a glass or ceramic envelope. The acorn tube is used in low-power uhf circuits.

AMPLIFICATION - The ratio of output magnitude to input magnitude in a device intended to produce an output that is an enlarged reproduction of its input.

AMPLIFICATION FACTOR - The voltage gain of an amplifier with no load on the output.

AMPLITUDE DISTORTION - Distortion that is present in an amplifier when the amplitude of the output signal fails to follow exactly any increase or decrease in the amplitude of the input signal.

AMPERITE (BALLAST) TUBE - A current-controlling resistance device designed to maintain substantially constant current over a specified range of variation in applied voltage or resistance of a series circuit.

ANODE - A positive electrode of an electrochemical device (such as a primary or secondary electric cell) toward which the negative ions are drawn.

AQUADAG COATING - A special coating of a conductive material, such as graphite, which is applied to the inside of a CRT. This coating eliminates the effects of secondary emission and aids in the acceleration of electrons.

BEAM-POWER TUBE - An electron tube in which the grids are aligned with the control grid. Special beam-forming plates are used to concentrate the electron stream into a beam. Because of this action, the beam-power tube has high power-handling capabilities.

BRIGHTNESS CONTROL - The name given to the potentiometer used to vary the potential applied to the control grid of a CRT.

CATHODE - The general name for any negative electrode.

CATHODE BIAS - The method of biasing a vacuum tube by placing the biasing resistor in the common-cathode return circuit, thereby making the cathode more positive with respect to ground.

NEETS MODULE 6-Electronic Emission, Tubes, and Power Supplies UNCLASSIFIED

CATHODE-RAY TUBE (CRT) - An electron tube that has an electron gun, a deflection system, and a screen. This tube is used to display visual electronic signals.

CHOKER - An inductor used to impede the flow of pulsating dc or ac by means of self-inductance.

COLD-CATHODE TUBE - A gas-filled electron tube that conducts without the use of filaments. Cold-cathode tubes are used as voltage regulators.

CONTROL GRID - The electrode of a vacuum tube, other than a diode, upon which a signal voltage is impressed to regulate the plate current.

DEFLECTION PLATES - Two pairs of parallel electrodes, one pair set forward of the other and at right angles to each other, parallel to the axis of the electron stream within an electrostatic cathode-ray tube.

DEIONIZATION POTENTIAL - The potential at which ionization of the gas within a gas-filled tube ceases and conduction stops, also referred to as extinction potential.

DIFFERENCE OF POTENTIAL - The voltage existing between two points. It will result in the flow of electrons whenever a circuit is established between the two points.

DIODE - An electron tube containing two electrode, a cathode, and a plate.

DIRECTLY HEATED CATHODE - A wire, or filament, designed to emit electrons that flow from cathode to plate. This is done by passing a current through the filament; the current heats the filament to the point where electrons are emitted.

DISTORTION - An undesired change in the waveform of the original signal, resulting in an unfaithful reproduction of audio or video signals.

DOORKNOB TUBE - An electron tube that is similar to the acorn tube but larger. The doorknob tube is designed to operate (at high power) in the uhf frequencies.

E_p - I_p CURV - The characteristic curve of an electron tube used to graphically depict the relationship between plate voltage (E_p) and the plate current (I_p).

EDISON EFFECT - Also called Richardson Effect. The phenomenon wherein electrons emitted from a heated element within a vacuum tube will flow to a second element that is connected to a positive potential.

ELECTRON GUN - An electrode of a CRT that is equivalent to the cathode and control grid of conventional tubes. The electron gun produces a highly concentrated stream of electrons.

NEETS MODULE 6-Electronic Emission, Tubes, and Power Supplies UNCLASSIFIED

ELECTROSTATIC DEFLECTION - The method of deflecting an electron beam by passing it between parallel charged plates mounted inside a cathode-ray tube.

FILAMENT - The cathode of a thermionic tube, usually a wire or ribbon, which is heated by passing current through it.

FILTER - A selective network of resistors, capacitors, and inductors that offer comparatively little opposition to certain frequencies or to direct current, while blocking or attenuating other frequencies.

FIXED BIAS - A constant value of bias voltage.

FLEMING VALVE - An earlier name for a diode, or a two-electrode vacuum tube used as a detector.

FOCUSING ANODE - An electrode of a CRT that is used to focus the electrons into a tight beam.

FULL-WAVE RECTIFIER - A circuit that uses both positive and negative alternations in an alternating current to produce direct current.

GETTER - An alkali metal introduced into a vacuum tube during manufacture. It is fired after the tube has been evacuated to react chemically with (and eliminate) any remaining gases.

GRID BIAS - A constant potential applied between the grid and cathode of a vacuum tube to establish an operating point.

GRID CURRENT - The current that flows in the grid-to-cathode circuit of a vacuum tube.

GRID-LEAK BIAS - A high resistance connected across the grid capacitor or between the grid and cathode. It provides a dc path to limit the accumulation of a charge on the grid.

HALF-WAVE RECTIFIER - A rectifier using only one-half of each cycle to change ac to pulsating dc.

HEATER - Same as a filament.

HORIZONTAL-DEFLECTION PLATES - A pair of parallel electrodes in a CRT that moves the electron beam from side to side.

NEETS MODULE 6-Electronic Emission, Tubes, and Power Supplies

UNCLASSIFIED

IMPLOSION - The inward bursting of a CRT due to high vacuum. The opposite of explosion.

INDIRECTLY HEATED CATHODE - Same as a directly heated cathode with one exception: The hot filament raises the temperature of the sleeve around the filament; the sleeve then becomes the electron emitter.

INTERELECTRODE CAPACITANCE - The capacitance between one electron-tube electrode and the next electrode toward the anode.

IONIZATION - The electrically charged particles produced by high energy radiation, such as light or ultraviolet rays, or by the collision of particles during thermal agitation.

IONIZATION POINT - The potential required to ionize the gas of a gas-filled tube. Sometimes called firing point.

LIGHTHOUSE TUBE - An electron tube shaped like a lighthouse, is designed to handle large amounts of power at uhf frequencies.

LINEAR - Having an output that varies in direct proportion to the input.

MULTI-ELECTRODE TUBE - An electron tube that is normally classified according to the number of grids. (The multi-electrode tube contains more than three grids).

MULTI-UNIT TUBE - An electron tube containing two or more units within the same envelope. The multi-unit tube is capable of operating as a single-unit tube or as separate tubes.

NONLINEAR - Having an output that does not rise or fall directly with the input.

OILCAN TUBE - A type of planar tube, similar to the lighthouse tube, which has cooling fins. The oilcan tube is designed to handle large amounts of power at uhf frequencies.

PEAK CURRENT - The maximum current that flows during a complete cycle.

PEAK-REVERSE VOLTAGE - The peak ac voltage which a rectifier tube will withstand in the reverse direction.

PEAK VOLTAGE - The maximum value present in a varying or alternating voltage. This may be positive or negative.

PENTODE TUBE - A five-electrode electron tube containing a plate, a cathode, a control grid, and two grids.

NEETS MODULE 6-Electronic Emission, Tubes, and Power Supplies

UNCLASSIFIED

PERSISTENCE - The duration of time a display remains on the face of a CRT.

PHOSPHOR - The material used to convert the energy of electrons into visible light.

PLANAR TUBE - An electron tube, constructed with parallel electrodes and a ceramic envelope, which is used at uhf frequencies. It is commonly referred to as lighthouse tube.

PLATE DISSIPATION - The amount of power lost as heat in the plate of a vacuum tube.

PLATE RESISTANCE - The plate voltage change divided by the resultant plate current change in a vacuum tube, all other conditions being fixed.

POWER PENTODE - A special-purpose tube used to provide high-current gain or power amplification. Each grid wire is directly in line with the one before and after it, a fact that allows more electrons to reach the plate.

POWER SUPPLY - A unit that supplies electrical power to another unit. It changes ac to dc and maintains a constant voltage output within limits.

QUIESCENCE - The operating condition of a circuit when no input signal is being applied to the circuit.

RECTIFIER - A device which, by its construction characteristics, converts alternating current to a pulsating direct current.

REGULATOR - The section in a basic power supply that maintains the output of the power supply at a constant level in spite of large changes in load current or in input line voltage.

REMOTE-CUTOFF TUBE - An electron tube in which the control grid wires are farther apart at the centers than at the ends. This arrangement allows the tube to amplify large signals without being driven into cutoff. This tube is also called a **VARIABLE- μ** tube.

rgk - The symbol used to express the resistance between the grid and the cathode of an electron tube.

rpk - The symbol used to represent the variable resistance between the cathode and the plate of a tube.

RIPPLE FREQUENCY - The frequency of the ripple current. In a full-wave rectifier, it is twice the input line frequency.

NEETS MODULE 6-Electronic Emission, Tubes, and Power Supplies UNCLASSIFIED

RIPPLE VOLTAGE - The alternating component of unidirectional voltage. (This component is small compared to the direct component).

SATURATION - The point in a tube where a further increase in plate voltage no longer produces an increase in plate current. At this point the upper limit of the conduction capabilities of the tube has been reached.

SECONDARY EMISSION - The liberation of electrons from an element, other than the cathode, as a result of being struck by other high-velocity electrons.

SCREEN GRIN - A grid placed between a control grid and the plate and usually maintained at a positive potential.

SELF-BIAS - The voltage developed by the flow of vacuum-tube current through a resistor in a grid or cathode lead.

SHARP-CUTOFF TUBE - The opposite of a remote-cutoff tube. An electron tube which has evenly spaced grid wires. The amplification of the sharp-cutoff tube is limited by the bias voltage and characteristics.

SPACE CHARGE - An electrical charge distributed throughout a volume or space.

TETRODE TUBE - A four-electrode electron tube containing a plate, a cathode, a control grid, and a screen grid.

THERMIONIC EMISSION - Emission of electrons from a solid body as a result of elevated temperature.

THYRATRON TUBE - A gas-filled triode in which a sufficiently large positive pulse applied to the control grid ionizes the gas and causes the tube to conduct, after which the control grid has no effect in conduction.

TRANSCONDUCTANCE - A measure of the change in plate current to a change in grid voltage with the plate voltage held constant. Transconductance (gm) is usually expressed in micromhos or millimhos. Mathematically,

$$g_m = \frac{I_p}{E_g}$$

TRANSIT TIME - The time an electron takes to cross the distance between the cathode and the plate.

TRIODE TUBE - A three-electrode electron tube containing a plate, a cathode, and a control grid.

NEETS MODULE 6-Electronic Emission, Tubes, and Power Supplies
UNCLASSIFIED

VARIABLE-mu-TUBE - Same as remote-cut off tube.

VERTICAL DEFLECTION PLATES - A pair of parallel electrodes in a CRT that moves the electron beam up and down.

VOLTAGE GAIN - Ratio of voltage across a specified load.

NEETS MODULE 6-Electronic Emission, Tubes, and Power Supplies
UNCLASSIFIED

ASSIGNMENT 1

Textbook assignment: Chapter 1, "Introduction to Electron Tubes," pages 1-1 through 1-79.

- 1-1. The electrons emitted by a heated conductor come from what source?
1. An external battery
 2. An external ac source
 3. Both 1 and 2 above
 4. The conductor itself
- 1-2. What is another name for thermionic emission?
1. The gap effect
 2. The heat effect
 3. The Edison effect
 4. The Fleming effect
- 1-3. Electrons emitted by a hot filament are able to cross the gap between the filament and the plate. What force enables them to do this?
1. Magnetic repulsion
 2. Inductive reactance
 3. Thermionic emission
 4. Electrostatic attraction
- 1-4. Name the two series circuits that are associated with a diode electron tube.
1. The plate and anode circuits
 2. The plate and filament circuits
 3. The battery and filament circuits
 4. The filament and cathode circuits
- 1-5. When an ac voltage is applied across the plate and filament of a diode, the current measured will represent what type of waveform?
1. Pulsating dc
 2. Dc
 3. Pulsating ac
 4. Ac

NEETS MODULE 6-Electronic Emission, Tubes, and Power Supplies
UNCLASSIFIED

- 1-6. A filament that uses a one-molecule-thick layer of barium and strontium is classified as what type of filament?
1. Tungsten
 2. Oxide-coated
 3. Tungsten-strontium
 4. Thoriated-tungsten
- 1-7. Which of the following ac filament voltages is most likely to be considered a common voltage?
1. 1.5 volts
 2. 3.0 volts
 3. 6.3 volts
 4. 9.0 volts
- 1-8. An ac directly heated filament has which of the following advantages?
1. Even spacing relative to the plate
 2. Even emission across the filament
 3. Constant emission throughout the ac cycle
 4. Rapid heating effect
- 1-9. An indirectly heated cathode always uses what material for its emitting surface?
1. An oxide coating
 2. A thorium coating
 3. A tungsten coating
 4. A graphite coating
- 1-10. What is the principal advantage of an indirectly heated cathode over a directly heated cathode?
1. It is larger
 2. It is immune to ac heater current variations
 3. It reaches an operating temperature more quickly
 4. It has a lower operating temperature

NEETS MODULE 6-Electronic Emission, Tubes, and Power Supplies
UNCLASSIFIED

1-11. When you view an electron tube and its socket connection from the bottom, in what direction are (a) the pins of the tube and (b) the pins of the socket numbered?

1. (a) Counterclockwise (b) Clockwise
2. (a) Counterclockwise (b) Counterclockwise
3. (a) Clockwise (b) Counterclockwise
4. (a) Clockwise (b) Clockwise

1-12. Electron tubes are identified by a number preceded by which of the following letter designations?

1. T
2. V
3. ET
4. VT

1-13. The getter in an electron tube serves what purpose?

1. It protects the plate from overheating
2. It allows the cathode to emit more electrons
3. It helps to produce a better vacuum
4. It anchors the tube elements in the base

IN ANSWERING QUESTIONS 1-14 THROUGH 1-16, MATCH EACH TERM LISTED IN COLUMN A WITH ITS ASSOCIATED ELECTRONIC SYMBOL LISTED IN COLUMN B

A. TERMS

B. SYMBOLS

1-14. Dc plate resistance

1. E_p

1-15. Dc plate current

2. e_p

1-16. Dc plate voltage

3. I_p

4. R_p

NEETS MODULE 6-Electronic Emission, Tubes, and Power Supplies
UNCLASSIFIED

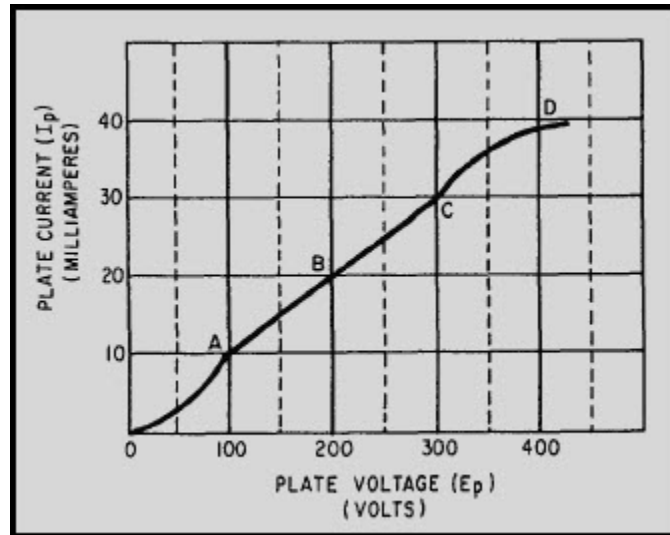

Figure 1A E_p — I_p characteristic curve

IN ANSWERING QUESTIONS 1-17 THROUGH 1-23, REFER TO FIGURE 1A.

- 1-17. The area of the graph that lies between points C and D is referred to as
1. nonlinear
 2. straight
 3. linear
 4. curved
- 1-18. In most applications, a designer would try to ensure that an electron tube operates at which of the following points on the curve?
1. A
 2. B
 3. C
 4. D
- 1-19. An electron tube operating at point A on the curve would have what plate resistance?
1. 7 k Ω
 2. 10 k Ω
 3. 30 k Ω
 4. 100 k Ω

NEETS MODULE 6-Electronic Emission, Tubes, and Power Supplies
UNCLASSIFIED

1-20. An electron tube operating at point D can be said to be in what condition?

1. Plate saturation
2. Cathode saturation
3. Both 1 and 2 above
4. Normal operation

MATCH EACH ELECTRON- TUBE OPERATING CHARACTERISTIC IN COLUMN A WITH ITS CORRESPONDING CHARACTERISTIC- CURVE POINT IN COLUMN B.

A. CHARACTERISTICS

B. POINTS

1-21. Conduction occurs only at the outer fringe of the space charge

1. A

1-22. All the electrons of the space charge are attracted to the plate

2. B

1-23. The point at which the tube can be operated most efficiently

3. C

4. D

1-24. An electron tube is operated at 300 volts and a plate current of 60 milliamperes. To avoid being damaged, the tube must have what minimum plate dissipation rating?

1. 5000 watts
2. 18 watts
3. 5 watts
4. 0.18 watt

1-25. Under which of the following conditions can a tube be considered operating beyond its peak inverse voltage rating?

1. When the plates glow cherry red
2. When current flows from the plate to the cathode
3. When current flows from the cathode in the form of an arc
4. When current flows from the cathode to the plate and damage occurs

NEETS MODULE 6-Electronic Emission, Tubes, and Power Supplies
UNCLASSIFIED

1-26. Why does control grid voltage of a triode exercise greater control than plate voltage over conduction of the tube?

1. The grid is operated at a higher voltage than the plate
2. The grid adds electrons to the electron stream
3. The grid is closer to the plate than the cathode
4. The grid is closer to the cathode than the plate

1-27. The plate load resistor in an electron-tube circuit performs what function?

1. It converts variations in plate voltage to current variations
2. It limits the amount of plate voltage that can be applied to the tube
3. It converts variations in plate current to variations in plate voltage
4. It limits the amount of plate current that can flow through the tube

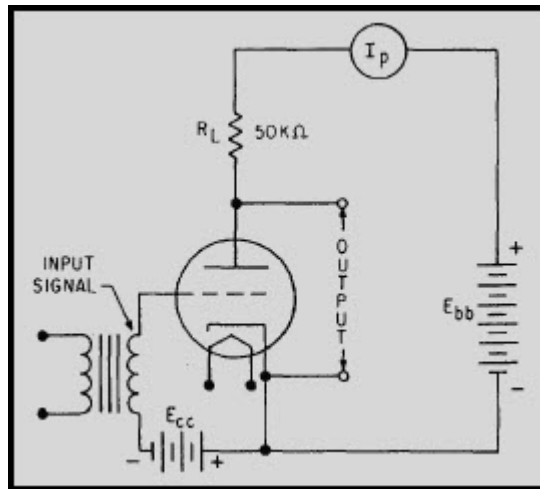

Figure 1B Triode operation

1-28. The triode circuit depicted in figure 1B above contains a 50 k Ω load resistor. When a 10-volt peak-to-peak ac signal is applied to the grid, current flow in the tube varies between 5 milliamperes and 12 milliamperes. What is the peak-to-peak amplitude of the output?

1. 500 volts
2. 350 volts
3. 250 volts
4. 150 volts

NEETS MODULE 6-Electronic Emission, Tubes, and Power Supplies
UNCLASSIFIED

- 1-29. Most amplifier circuits are designed to operate with the grid negative in relation to the cathode. This is done to avoid which of the following problems?
1. Excessive grid current
 2. Excessive plate current
 3. Distortion on small signals
 4. Distortion on large negative signals
- 1-30. A triode amplifier has 350 volts applied to its plate across a 25 k Ω load resistor. With no input signal applied and a bias voltage of -9 volts, 4 milliamperes conducts across the tube. What is the quiescent plate voltage?
1. 0 V
 2. 100 V
 3. 250 V
 4. 350 V
- 1-31. A triode electron tube is designed to conduct at 15 milliamperes of current when its grid is at 0 volts relative to its cathode. For every volt below this, conduction will decrease by 1.5 milliamperes. If the tube is biased at -3 volts and has a 6-volt peak-to-peak input signal, what is the minimum amount of current that will conduct through the tube?
1. 11.5 milliamperes
 2. 6.0 milliamperes
 3. 1.5 milliamperes
 4. 0 milliamperes
- 1-32. Overdriving can be considered a form of distortion for which of the following reasons?
1. The output is not in phase with the input
 2. The output does not have the same polarity as the input
 3. The output is not a faithful reproduction of the input
 4. The output does not have the same amplitude as the input

NEETS MODULE 6-Electronic Emission, Tubes, and Power Supplies
UNCLASSIFIED

IN ANSWERING QUESTIONS 1-33 THROUGH 1-35, MATCH EACH CONDITION AFFECTING TRIODE AMPLIFIER OPERATION IN COLUMN A WITH ITS CORRESPONDING ELECTRONIC TERM IN COLUMN B.

A. CONDITIONS

B. TERMS

1-33. Condition that exists when the positive and negative excursions of the output are "flattopped"

1. Cutoff
2. Saturation
3. Overdriving
4. Current limiting

1-34. A form of distortion that can occur only during the positive excursion of the ac input of a triode amplifier

1-35. A form of distortion that can only occur in a triode amplifier during the negative excursion of the input

1-36. Electronic equipment that uses fixed bias for its tube circuit receives its grid-bias voltage from what source?

1. A portion of the plate voltage
2. A power source internal to the circuit
3. Both 1 and 2 above
4. A power source external to the circuit

1-37. The effect of both cathode and grid biasing is to make the cathode (a) what polarity, relative to (b) what other tube element?

1. (a) Positive (b) the plate
2. (a) Negative (b) the plate
3. (a) Positive (b) the grid
4. (a) Negative (b) the grid

NEETS MODULE 6-Electronic Emission, Tubes, and Power Supplies
UNCLASSIFIED

- 1-38. Which of the following types of biasing is most likely to use a battery supply?
1. Self
 2. Grid
 3. Fixed
 4. Cathode
- 1-39. In an electron tube circuit using cathode biasing, the cathode is made positive in relation to the grid. This is done by a voltage dropped across what circuit element?
1. R_L
 2. R_k
 3. C_c
 4. C_k
- 1-40. The cathode bias voltage level applied to the cathode is maintained at a constant level by what circuit component?
1. R_L
 2. R_k
 3. C_c
 4. C_k
- 1-41. Which of the following undesirable characteristics is associated with cathode biasing?
1. Plate voltage is increased by the voltage amount of biasing
 2. The cathode is forced to operate at a positive potential
 3. The maximum negative output is limited
 4. Current must flow in the circuit continuously
- 1-42. Grid-leak biasing develops a biasing voltage from (a) what portion of the input signal and (b) by what type of action?
1. (a) Negative (b) resistive
 2. (a) Negative (b) capacitive
 3. (a) Positive (b) capacitive
 4. (a) Positive (b) resistive

NEETS MODULE 6-Electronic Emission, Tubes, and Power Supplies
UNCLASSIFIED

- 1-43. During the charge cycle in grid-leak biasing, C_c draws current through what circuit element?
1. R_g
 2. rgk
 3. R_L
 4. R_k
- 1-44. During the discharge cycle in grid-leak biasing, C_c discharges across what circuit element?
1. R_g
 2. rgk
 3. R_L
 4. R_k
- 1-45. The effect of grid-leak biasing is to rectify the input signal. Because of this, the amplitude of the biasing voltage depends upon which of the following factors?
1. Amplitude of the input
 2. Frequency of the input
 3. Size of R_g and C_c
 4. All of the above
- 1-46. During the charging cycle in grid-leak biasing, the effective size of rgk is decreased. This is caused by what electronic principle?
1. Electrostatic repulsion between the grid and the plate
 2. Electrostatic repulsion between the grid and the cathode
 3. Electrostatic attraction between the cathode and the grid
 4. Electrostatic attraction between the plate and the cathode
- 1-47. The charge and discharge of capacitor C_c , used in grid-leak circuits, will be equal when what condition occurs?
1. When R_{gk} becomes the same value as R_g
 2. When C_c reaches its maximum charge-holding capacity
 3. When the charge on C_c cuts the tube off
 4. When R_g becomes larger than rgk

NEETS MODULE 6-Electronic Emission, Tubes, and Power Supplies
UNCLASSIFIED

IN ANSWERING QUESTIONS 1-48 THROUGH 1-50, MATCH EACH CHARACTERISTIC OF AMPLIFIER OPERATION IN COLUMN A WITH ITS ASSOCIATED CLASS OF AMPLIFIER IN COLUMN B.

A. CHARACTERISTICS

B. CLASSES

1-48. Conduction occurs in the tube during only 50% of the entire input cycle

1. A
2. AB
3. B
4. C

1-49. Conduction occurs in the tube throughout the entire input cycle

1-50. Conduction occurs in the tube for more than 50%, but less than 100% of the entire input cycle

1-51. A triode amplifier has a load resistor rated at 150 k Ω . A +3-volt signal will cause 4 milliamperes of current to conduct through the tube. What is the voltage gain of the amplifier?

1. 450
2. 200
3. 100
4. 50

1-52. The amplification factor for an electron tube is identified by what electronic symbol?

1. A_r
2. V_g
3. g_m
4. μ

NEETS MODULE 6-Electronic Emission, Tubes, and Power Supplies
UNCLASSIFIED

1-53. The grid voltage on an electron tube is increased from 2 volts to 4 volts. This causes plate current to increase from 2 milliamperes to 5.5 milliamperes. This same increase in plate current can be achieved by keeping the grid at +2 volts and raising the plate voltage from 200 volts to 400 volts. What is the μ of the tube?

1. 400
2. 200
3. 100
4. 50

1-54. What is the transconductance for the tube described in question 1-53?

1. 175 μmhos
2. 645 μmhos
3. 700 μmhos
4. 1750 μmhos

1-55. Transconductance is identified by what electronic symbol?

1. μ
2. g_m
3. r_{gk}
4. t_c

1-56. In a triode, what interelectrode capacitance has the greatest effect on tube operation?

1. C_{pg}
2. C_{gk}
3. C_{pk}
4. C_{sg}

1-57. Interelectrode capacitance (C_{pg}) affects the gain of a triode stage because of what electronic feature?

1. Blocking
2. Feedback
3. Transit time
4. Phase inversion

NEETS MODULE 6-Electronic Emission, Tubes, and Power Supplies
UNCLASSIFIED

1-58. The action of the screen grid in reducing interelectrode capacitance can be expressed mathematically as

1. $C_T = C_1 + C_2$

2. $C_T = C_1 \times C_2$

3. $C_T = \frac{C_1 + C_2}{C_1 \times C_2}$

4. $C_T = \frac{C_1 \times C_2}{C_1 + C_2}$

1-59. For normal operation, the screen grid of a tetrode is operated at a positive voltage in relation to (a) what tube element, and negative in relation to (b) what other tube element?

1. (a) Grid (b) plate
2. (a) Grid (b) cathode
3. (a) Plate (b) grid
4. (a) Cathode (b) grid

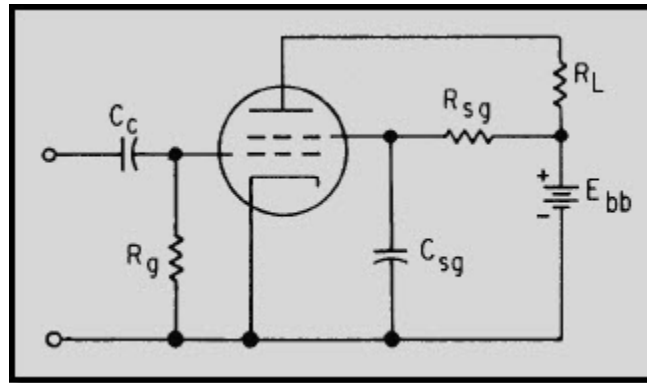

Figure 1C Basic tetrode circuit

1-60. What is the function of C_{sg} in figure 1C above?

1. It serves as a feedback capacitor
2. It bypasses ac signals from the screen grid to ground
3. It keeps dc voltages from being applied to the screen grid from ground
4. It couples ac signals from the cathode to the screen grid

NEETS MODULE 6-Electronic Emission, Tubes, and Power Supplies
UNCLASSIFIED

- 1-61. Which of the following undesirable characteristics is/are associated with tetrode operation?
1. The plate is isolated from the electron stream
 2. The plate emits secondary emission electrons
 3. The output is noisy
 4. Both 2 and 3 above
- 1-62. Generally, tetrodes have a lower transconductance than triodes. This is caused by what feature of a tetrode?
1. The plate is isolated from the electron stream
 2. The screen grid draws current from the electron stream
 3. Secondary emission limits the amount of current the plate can draw from the electron stream
 4. The screen grid is operated at a negative potential relative to the plate and electrons are repelled from the plate
- 1-63. The suppressor grid of a pentode is operated at what potential relative to (a) the cathode and (b) the plate?
1. (a) Positive (b) The same potential
 2. (a) Negative (b) The same potential
 3. (a) The same potential (b) Negative
 4. (a) The same potential (b) Positive
- 1-64. Voltage is supplied to the suppressor grid in a pentode from what source?
1. Through a resistor from the plate source voltage
 2. Through a resistor from ground
 3. By a separate voltage source
 4. By a physical connection from the cathode
- 1-65. The suppressor grid is able to control the effects of secondary emission by using which of the following electronic actions?
1. By attracting electrons emitted by the plate through electromagnetic attraction
 2. By repelling electrons emitted by the plate through electromagnetic repulsion
 3. By attracting electrons emitted from the plate through electrostatic attraction
 4. By repelling electrons emitted from the plate through electrostatic repulsion

NEETS MODULE 6-Electronic Emission, Tubes, and Power Supplies
UNCLASSIFIED

ASSIGNMENT 2

Textbook assignment: Chapter 2, "Special-Purpose Tubes," pages 2-1 through 2-51.

2-1. Which of the following types of tubes would be used as a voltage amplifier in an electronic circuit?

1. Diode
2. Triode
3. Duo-diode
4. Tetrahedral

2-2. Multielectrode tubes are normally classified according to the number of

1. units contained in the tube
2. grids contained in the tube
3. elements contained in the tube
4. filaments contained in the tube

2-3. How many grids are there in a pentagrid tube?

1. Five
2. Six
3. Seven
4. Eight

NEETS MODULE 6-Electronic Emission, Tubes, and Power Supplies
UNCLASSIFIED

2-4. Which of the following diagrams represents a twin pentode?

1.



2.

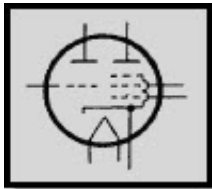

3.

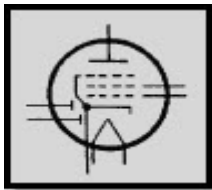

4.



NEETS MODULE 6-Electronic Emission, Tubes, and Power Supplies
UNCLASSIFIED

2-5. Which of the following diagrams represents a twin-input triode?

1.



2.



3.

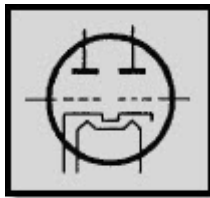

4.

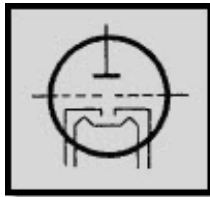

NEETS MODULE 6-Electronic Emission, Tubes, and Power Supplies
UNCLASSIFIED

- 2-6. What advantage(s) does the in-line grid arrangement of the power pentode have over the staggered grid arrangement of the conventional pentode?
1. Higher efficiency
 2. Higher power output
 3. Both 1 and 2 above
 4. Smaller current requirement
- 2-7. Which of the following is an advantage that a power pentode has over a conventional pentode?
1. Greater opposition to electron flow
 2. Higher gain because of staggered grids
 3. Greater sensitivity to small signals
 4. Smaller plate current obtained from large signals
- 2-8. What is the primary purpose of the beam-forming plates in the beam-power tube?
1. To concentrate the electrons into a beam
 2. To catch any stray electrons in the tube
 3. To act as an extension of the cathode
 4. To give the tube the appearance of a pentode
- 2-9. Which of the following is a name given to the variable-mu tube?
1. Sharp-cutoff tube
 2. Remote-cutoff tube
 3. Variable-spaced tube
 4. Reversible-bias tube
- 2-10. What is the symbol for "mu"?
1. μ
 2. β
 3. I
 4. L
- 2-11. Which of the following is an advantage of the variable-mu tube over conventional tubes?
1. It can be driven into cut-off by remote signals
 2. It can be saturated quickly with a small input signal
 3. It can amplify small input signals without distortion
 4. It can amplify large input signals without distortion

NEETS MODULE 6-Electronic Emission, Tubes, and Power Supplies
UNCLASSIFIED

- 2-12. What is the only difference between a remote-cutoff tube and a sharp-cutoff tube?
1. The spacing of the grid wires
 2. The number of grids in each tube
 3. The bias voltage used for conduction
 4. The potential on the elements of each tube
- 2-13. Which of the following is the BEST method for reducing transit time in uhf tubes?
1. Placing the elements very close together
 2. Increasing the voltage on the electrodes
 3. Increasing the velocity of electrons
 4. Placing the elements far apart
- 2-14. Which of the following is a disadvantage of uhf tubes?
1. Interelectrode capacitance is reduced
 2. They are manufactured without socket bases
 3. All the physical dimensions are scaled small
 4. They have reduced power-handling capabilities
- 2-15. What is the only physical difference between the doorknob tube and the acorn tube?
1. Size
 2. Base design
 3. Filament material
 4. Power-handling capability
- 2-16. How does the construction of a planar tube differ from that of a concentric tube?
1. Concentric tubes use filaments while planar tubes do not
 2. Planar tubes use filaments while concentric tubes do not
 3. The electrodes of the planar tubes are parallel to each other while those in concentric tubes are not
- 2-17. Why is the metallic ring of the planar tube grounded?
1. To eliminate shock hazards
 2. To eliminate unwanted rf signals
 3. To make removing the tube easier
 4. To shunt the cathode current to ground

NEETS MODULE 6-Electronic Emission, Tubes, and Power Supplies
UNCLASSIFIED

- 2-18. The metallic shell capacitive ground of a planar tube serves as what kind of capacitor in a cathode-bias circuit?
1. Grid
 2. Bypass
 3. Coupling
 4. Plate-to-cathode
- 2-19. What is the major difference between the oilcan tube and the lighthouse tube?
1. The oilcan tube has cooling fins; the lighthouse tube does not
 2. The oilcan tube functions as a triode
 3. The lighthouse tube can handle more power
 4. The lighthouse tube is a diode-type tube
- 2-20. Which of the following is an advantage that an oilcan tube has over a lighthouse tube?
1. The oilcan tube is smaller
 2. The oilcan tube has no filaments
 3. The oilcan tube can handle more power
 4. The oilcan tube can operate at hf and uhf frequencies
- 2-21. The plate potential at which ionization occurs is known as the ionization point. Which of the following is also a name for this process?
1. Firing potential
 2. Saturation potential
 3. Extinction potential
 4. Deionization potential
- 2-22. What name is given to the value of plate voltage at which ionization stops?
1. Firing potential
 2. Saturation potential
 3. Extinction potential
 4. High plate potential
- 2-23. When a gas-filled triode ionizes, the grid loses control and the tube then functions as what type of tube?
1. Diode
 2. Triode
 3. Duo-diode
 4. Trigatron

NEETS MODULE 6-Electronic Emission, Tubes, and Power Supplies
UNCLASSIFIED

- 2-24. After the gas-filled triode ionizes and the grid loses control, which of the following methods is used to stop the conduction of the tube?
1. Increasing the plate potential
 2. Increasing the grid potential
 3. Removing the plate potential
 4. Removing the grid potential
- 2-25. What is the name given to the gas-filled triode?
1. Variable triode
 2. Trigatron
 3. Thyristor
 4. Thyatron
- 2-26. For what minimum amount of time must the filaments of a mercury-vapor tube have voltage applied before the plate voltage is applied to the tube?
1. 0.5 minute
 2. 1.5 minutes
 3. 2.5 minutes
 4. 3.0 minutes
- 2-27. Which of the following conditions is/are responsible for the soft, blue glow of the gas-filled triode?
1. The tube is operating normally
 2. The tube is gassy
 3. The tube is saturated
 4. The tube is ionized
- 2-28. Which of the following types of tubes is normally used as a voltage regulator?
1. Gas-filled triode
 2. Gas-filled diode
 3. Cold cathode
 4. Cold plate

NEETS MODULE 6-Electronic Emission, Tubes, and Power Supplies
UNCLASSIFIED

2-29. For a cold-cathode tube, how does the voltage regulator maintain a constant voltage drop across the tube?

1. By changing the current flow of the tube
2. By changing the resistance of the tube as current flow varies
3. By changing the plate potential of the tube as current varies
4. By changing the source voltage of the tube

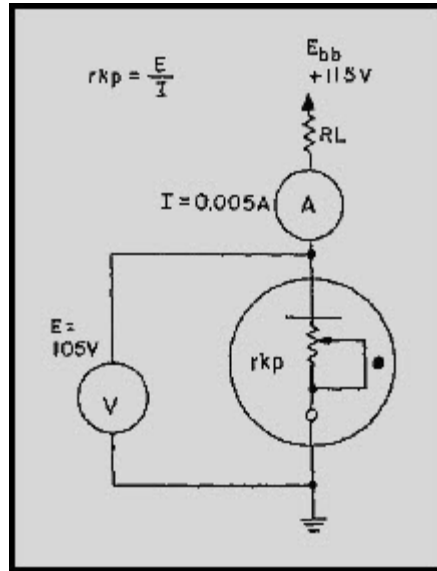

Figure 2A Cold-cathode tube operation

2-30. If the source voltage in figure 2A is increased to 150 volts and the ammeter reads 20 milliamperes, what is the resistance (r_{kp}) of the tube?

1. 2.65 k Ω
2. 5.25 k Ω
3. 6.25 k Ω
4. 8.15 k Ω

2-31. The electron gun of the CRT serves which of the following functions?

1. Deflects electrons into the plate
2. Concentrates electrons into a beam
3. Emits electrons
4. Both 2 and 3 above

NEETS MODULE 6-Electronic Emission, Tubes, and Power Supplies
UNCLASSIFIED

- 2-32. Which of the following is a description of the grid in a CRT?
1. A metal cap with a hole in the center
 2. A metal cap at ground potential
 3. A metal cap with a positive potential
 4. A metal cap with a wire screen in the center
- 2-33. What element of a television CRT is adjusted by the brightness control?
1. Cathode
 2. Aquadag
 3. Control grid
 4. Focusing anode
- 2-34. Which of the following elements of the CRT helps prevent the beam of electrons from diverging?
1. Cathode
 2. Aquadag
 3. Focusing anode
 4. Decelerating anode
- 2-35. Which of the following elements of a CRT has the highest positive potential?
1. The focusing anode
 2. The electronic lens
 3. The accelerating anode
 4. The decelerating anode
- 2-36. What is the name of the florescent material that coats the inside face of a CRT?
1. Posporus
 2. Phosphor
 3. Flourine
 4. Flourese
- 2-37. What is the purpose of the aquadag coating in the CRT?
1. It is used as a plate
 2. It is used to focus the beam
 3. It eliminates the space charge
 4. It eliminates the effects of secondary emission

NEETS MODULE 6-Electronic Emission, Tubes, and Power Supplies
UNCLASSIFIED

- 2-38. In which of the following equipment would you most likely find a cathode-ray tube?
1. Oscillator
 2. Oscilloscope
 3. Television set
 4. Both 2 and 3
- 2-39. If deflection were not used in the CRT, what would be viewed on the screen of the tube?
1. A solid black screen
 2. A solid white screen
 3. A large spot on the left
 4. A bright spot in the center
- 2-40. Which of the following types of deflection is used by much of the test equipment in the Navy?
1. Electromagnetic
 2. Electrostatic
 3. Magnetic
 4. Static
- 2-41. Which of the following elements cause(s) the electron beam to move from left to right on a CRT?
1. Vertical deflection plates
 2. Horizontal deflection plates
 3. Suppressor grid
 4. Control grid

NEETS MODULE 6-Electronic Emission, Tubes, and Power Supplies
UNCLASSIFIED

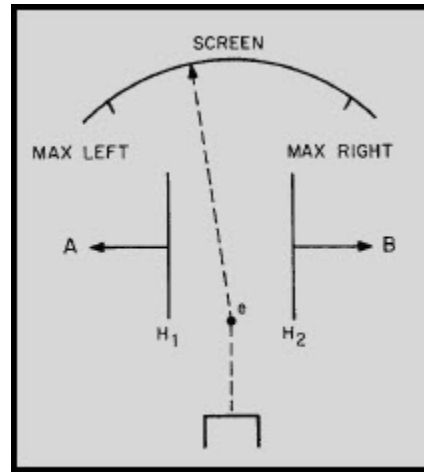

Figure 2B Deflection in a CRT

- 2-42. In figure 2B, what potentials should be applied to points A and B to make electron (e) deflect in the direction as shown?
1. Point A zero and point B max positive
 2. Point A max negative and point B max positive
 3. Point A slightly positive and point B slightly negative
 4. Point A slightly positive and point B zero

NEETS MODULE 6-Electronic Emission, Tubes, and Power Supplies
UNCLASSIFIED

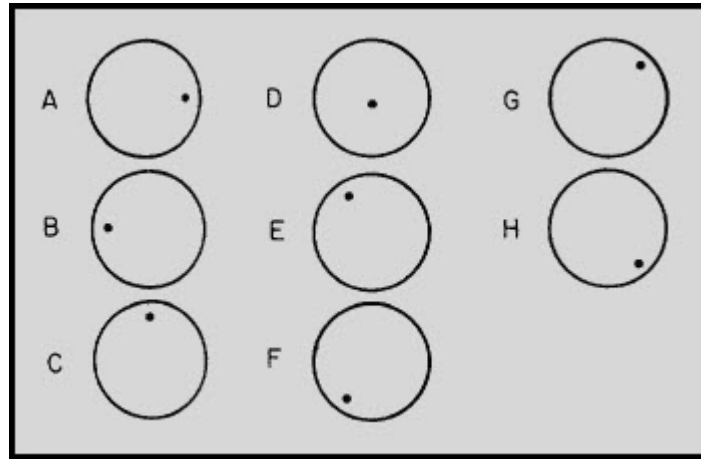
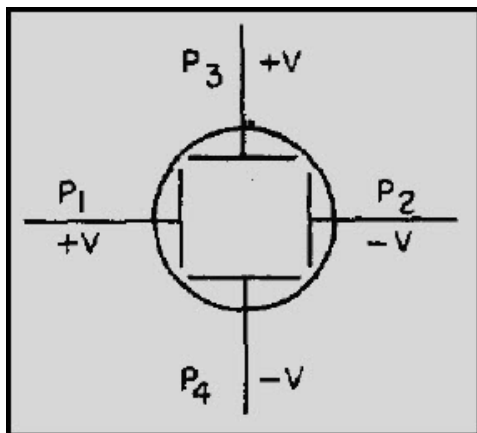

Figure 2C Deflection in a CRT (front view)

IN ANSWERING QUESTIONS 2-43 THROUGH 2-45, REFER TO FIGURE 2C. SELECT FROM CHOICES A THROUGH H THE DOT DISPLAY THAT MOST ACCURATELY REPRESENTS THE CONDITIONS OF THE PLATES SHOWN FOR EACH QUESTION.

2-43.

1. E
2. F
3. G
4. H



NEETS MODULE 6-Electronic Emission, Tubes, and Power Supplies
UNCLASSIFIED

2-44.

1. A
2. B
3. C
4. D

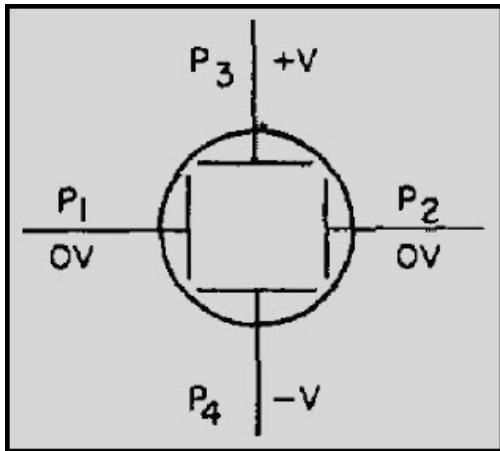

2-45.

1. A
2. B
3. C
4. D

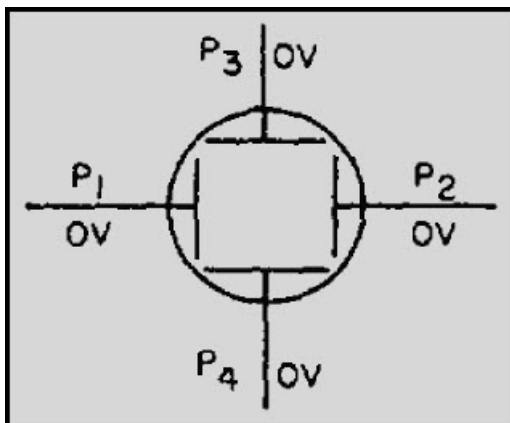

NEETS MODULE 6-Electronic Emission, Tubes, and Power Supplies
UNCLASSIFIED

2-46. If a signal is to be viewed on a CRT, the signal should be applied to which of the following elements of the CRT?

1. Control grid
2. Vertical plates
3. Suppressor grid
4. Horizontal plates

IN ANSWERING QUESTIONS 2-47 THROUGH 2-56, SELECT FROM COLUMN B THE ELEMENT OF THE CRT WHICH PROVIDES THE FUNCTION DESCRIBED IN COLUMN A. YOU MAY USE THE ELEMENTS IN COLUMN B MORE THAN ONE TIME.

A. FUNCTIONS	B. ELEMENTS
2-47. Reduces interelectrode capacitance	1. Cathode
2-48. Controls electrons	2. Control grid
2-49. Source of electrons	3. Focusing anode
2-50. Accelerates electrons	4. Accelerating anode
2-51. Focuses electrons into a beam	

NEETS MODULE 6-Electronic Emission, Tubes, and Power Supplies
UNCLASSIFIED

A. FUNCTIONS

B. ELEMENTS

- | | |
|--------------------------------------|---------------------------------|
| 2-52. Acts as suppressor grid | 1. Vertical deflection plates |
| 2-53. Displays electron beam | 2. Horizontal deflection plates |
| 2-54. Deflects beam to right | 3. Aquadag coating |
| 2-55. Deflects beam to down position | 4. Screen |
- 2-56. Eliminates secondary emission
- 2-57. Which of the following actions must you take first before disposing of a cathode-ray tube?
1. Place the CRT carefully in a dumpster
 2. Throw the CRT into deep water
 3. Return the CRT to supply
 4. Render the CRT harmless
- 2-58. What is the purpose of adding radioactive material to electron tubes?
1. The material reduces secondary emissions
 2. The material aids ionization in the tube
 3. The material increases thermionic emission
 4. The material causes the tube to glow in the dark
- 2-59. Safety precautions and procedures for working with radioactive electron tubes can be found in which of the following publications?
1. Radiation, Health, and Protection Manual
 2. Decontamination of Radioactivity Manual
 3. Technical Manual for RF Radiation Hazards
 4. Radiation Hazards of Shipboard Equipment Manual

NEETS MODULE 6-Electronic Emission, Tubes, and Power Supplies
UNCLASSIFIED

ASSIGNMENT 3

Textbook assignment: Chapter 3, "Power Supplies," pages 3-1 through 3-82.

- 3-1. The electronic power supply was developed to fulfill which of the following needs?
1. Reliability
 2. Convenience
 3. Cost effectiveness
 4. All of the above
- 3-2. Which of the following is NOT one of the four sections of a basic power supply?
1. Transformer
 2. Oscillator
 3. Rectifier
 4. Filter
- 3-3. The primary purpose of the transformer in an electronic power supply is to isolate the power supply from ground.
1. True
 2. False
- 3-4. What is the primary function of the rectifier section?
1. To convert dc to ac
 2. To convert ac to pulsating dc
 3. To increase average voltage output
 4. To decrease average voltage output
- 3-5. What is/are the function(s) of the filter section?
1. To eliminate dc voltage
 2. To increase the amplitude of the ac
 3. To convert pulsating dc to steady dc
 4. All of the above

NEETS MODULE 6-Electronic Emission, Tubes, and Power Supplies
UNCLASSIFIED

- 3-6. The separate step-down windings in a transformer provide which of the following functions?
1. Filament voltage for power supply tubes
 2. Filament voltage for the electronic load
 3. Both 1 and 2 above
 4. High voltage for the rectifier
- 3-7. The purpose of a center tap in a transformer is to provide
1. two separate filament voltages to the rectifier
 2. a step-down voltage to the rectifier
 3. pulsating dc to the rectifier
 4. two outputs from one transformer
- 3-8. A diode vacuum tube is an ideal rectifier for which, if any, of the following reasons?
1. Current flows through the diode vacuum tube in one direction only
 2. Current flows through the diode vacuum tube in both directions
 3. The diode vacuum tube conducts only on the negative alternation of the input voltage
 4. None of the above
- 3-9. When the plate of a diode tube is negative with respect to the cathode, the tube is said to be in what state?
1. Cutoff
 2. Remission
 3. Saturation
 4. Conduction
- 3-10. In a simple half-wave rectifier, the diode tube will conduct for a maximum of how many degrees of the 360-degree input signal?
1. 45
 2. 90
 3. 180
 4. 270

NEETS MODULE 6-Electronic Emission, Tubes, and Power Supplies
UNCLASSIFIED

- 3-11. What term is used to describe current pulses that flow in the same direction?
1. Average current
 2. Secondary current
 3. Pure direct current
 4. Pulsating direct current
- 3-12. For a diode to act as a rectifier, how should it be connected in a circuit?
1. In parallel with the input
 2. In parallel with the load
 3. In series with the input
 4. In series with the load
- 3-13. What is the ripple frequency of a half-wave rectifier with an input line frequency of 60 Hz?
1. 30 Hz
 2. 60 Hz
 3. 90 Hz
 4. 120 Hz
- 3-14. In a half-wave rectifier, what is the average voltage output when the peak voltage is 300 volts?
1. 190.8 volts
 2. 95.4 volts
 3. 19.08 volts
 4. 9.4 volts
- 3-15. The full-wave rectifier was developed for which of the following reasons?
1. To obtain the highest average voltage and current
 2. To increase the number of components
 3. To increase the value of the voltage
 4. To obtain better regulation
- 3-16. What is the ripple frequency of a full-wave rectifier with an input line frequency of 60 Hz?
1. 30 Hz
 2. 60 Hz
 3. 90 Hz
 4. 120 Hz

NEETS MODULE 6-Electronic Emission, Tubes, and Power Supplies
UNCLASSIFIED

- 3-17. What is the average voltage output of a full-wave rectifier that has an output of 10 volts peak?
1. 3.18 volts
 2. 6.37 volts
 3. 31.8 volts
 4. 63.7 volts
- 3-18. The primary disadvantage of the conventional full-wave rectifier is that the peak output voltage is only half that of the half-wave rectifier.
1. True
 2. False

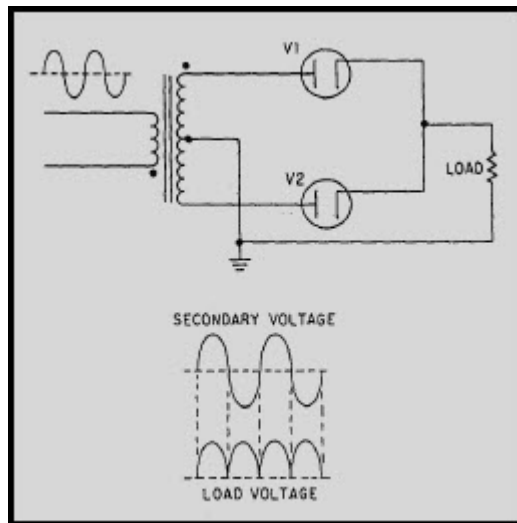

Figure 3A Complete full-wave rectifier

IN ANSWERING QUESTIONS 3-19 AND 3-20, REFER TO FIGURE 3A. ASSUME THAT THE VOLTAGE ACROSS THE TRANSFORMER SECONDARY HAS AN RMS VALUE OF 240 VOLTS AC.

- 3-19. What is the peak value of the voltage pulses across the load?
1. 339.4 volts
 2. 239.8 volts
 3. 169.7 volts
 4. 76.3 volts

NEETS MODULE 6-Electronic Emission, Tubes, and Power Supplies
UNCLASSIFIED

3-20. What is the average output voltage?

1. 237.5 volts
2. 169.7 volts
3. 152.3 volts
4. 108.1 volts

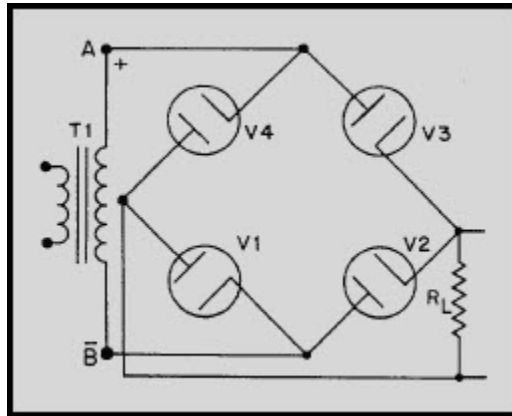

Figure 3B Bridge rectifier

IN ANSWERING QUESTIONS 3-21 AND 3-22, REFER TO FIGURE 3B.

3-21. When the voltage across the secondary of the transformer has the polarity shown, which of the diodes will conduct?

1. V1 and V3
2. V2 and V4
3. V1 and V2
4. V3 and V4

3-22. When the polarity reverses, which of the diodes will conduct?

1. V3 and V1
2. V4 and V2
3. V2 and V1
4. V4 and V3

3-23. In filter circuits, inductors are used as what kind of impedances?

1. Shunt impedances to oppose changes in current
2. Shunt impedances to oppose changes in voltage
3. Series impedances to oppose changes in current
4. Series impedances to oppose changes in voltage

NEETS MODULE 6-Electronic Emission, Tubes, and Power Supplies
UNCLASSIFIED

- 3-24. To retain its charge, the capacitor in a simple capacitor filter must have a long charge time constant and a short discharge time constant.
1. True
 2. False
- 3-25. If the capacitance in a circuit increases, X_c , will increase.
1. True
 2. False
- 3-26. To provide a steady dc output in a simple capacitor circuit, the capacitor must charge almost instantaneously to the value of the applied voltage.
1. True
 2. False
- 3-27. What is the most basic type of filter?
1. Capacitor
 2. LC choke input
 3. LC capacitor input
 4. RC capacitor input
- 3-28. In a circuit with a capacitor filter, how is the capacitor connected?
1. In series with the load
 2. In parallel with the load
 3. In parallel with the output
 4. Both 2 and 3 above
- 3-29. Which, if any, of the following factors determines the rate of discharge of the capacitor in a filter circuit?
1. The value of the load resistance
 2. The amount of voltage
 3. The type of capacitor
 4. None of the above

NEETS MODULE 6-Electronic Emission, Tubes, and Power Supplies
UNCLASSIFIED

- 3-30. A half-wave rectifier has an output frequency of 60 hertz, a filter capacitor value of 40 microfarads, and a load resistance of 10 kilohms. What is the value of X_c ?
1. 132.51 ohms
 2. 66.25 ohms
 3. 33.13 ohms
 4. 16.57 ohms
- 3-31. A full-wave rectifier has an output frequency of 120 hertz, a filter capacitor value of 25 microfarads, and a load resistance of 10 kilohms. What is the value of X_c ?
1. 5.3 ohms
 2. 53 ohms
 3. 106 ohms
 4. 1060 ohms
- 3-32. The LC choke-input filter is used primarily where which of the following types of regulation is/are important?
1. Frequency
 2. Current only
 3. Voltage only
 4. Voltage and current
- 3-33. In an LC choke-input filter circuit, the capacitor charges only to the average value of the input voltage. Which of the following components inhibits the capacitor from reaching the peak value of the input voltage?
1. Diode
 2. Capacitor
 3. Filter choke
 4. Load resistor
- 3-34. In an LC choke-input filter, the larger the value of the filter capacitor, the better the filtering action. Which of the following factors represents the major limitation in obtaining the maximum value of the capacitor used?
1. Cost
 2. Reliability
 3. Availability
 4. Physical size

NEETS MODULE 6-Electronic Emission, Tubes, and Power Supplies
UNCLASSIFIED

- 3-35. What is the most common range of values selected for a power supply choke?
1. 1 to 20 henries
 2. 5 to 25 henries
 3. 25 to 30 henries
 4. 10 to 200 henries
- 3-36. If the impedance of the choke in an LC choke-input filter is increased, the ripple voltage amplitude will
1. decrease
 2. increase
 3. oscillate
 4. remain the same
- 3-37. A full-wave rectifier has an output frequency of 120 hertz, a filter choke with a value of 10 henries, and a load resistance of 10 kilohms. What is the value of X_L ?
1. 75.0 ohms
 2. 7.5 ohms
 3. 75.0 kilohms
 4. 7.5 kilohms
- 3-38. The filter capacitor in the LC choke input filter is NOT subject to extreme voltage surges because of the protection provided by which of the following components?
1. Inductor
 2. Load resistor
 3. Series resistor
 4. Shunt capacitor
- 3-39. Shorted turns in the choke of an LC choke-input filter may reduce the value of inductance below the critical value. When this happens, which of the following problems may occur?
1. Poor voltage regulation
 2. Excessive ripple amplitude
 3. Abnormally high output voltage
 4. Each of the above

NEETS MODULE 6-Electronic Emission, Tubes, and Power Supplies
UNCLASSIFIED

3-40. The use of the RC capacitor-input filter is limited to which of the following situations?

1. When the load current is large
2. When the load current is small
3. When the load voltage is large
4. When the load voltage is small

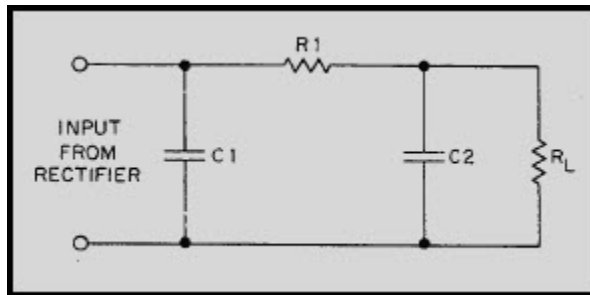

Figure 3C RC Capacitor-input filter

IN ANSWERING QUESTIONS 3-41 AND 3-42, REFER TO FIGURE 3C.

3-41. Which of the following components will have the highest failure rate?

1. C1
2. C2
3. R1
4. RL

3-42. Which of the following components provides protection against voltage surges in the circuit?

1. C1
2. C2
3. R1
4. RL

NEETS MODULE 6-Electronic Emission, Tubes, and Power Supplies
UNCLASSIFIED

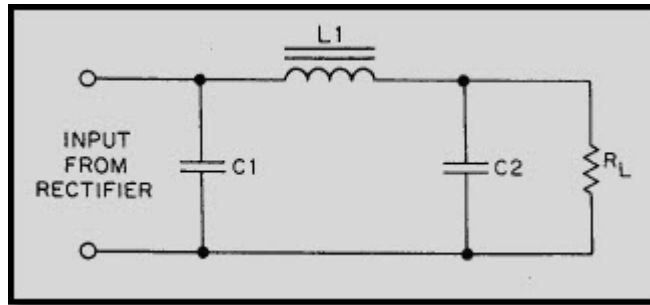

Figure 3D LC capacitor-input filter

IN ANSWERING QUESTIONS 3-43 AND 3-44, REFER TO FIGURE 3D.

3-43. Components L1 and C2 form what type of circuit?

1. Ac voltage doubler
2. Dc voltage doubler
3. Ac voltage divider
4. Dc voltage divider

3-44. If component L1 shorts to the core, which of the following conditions will result?

1. No output
2. Excessively high output
3. Excessive ripple frequency
4. Low output ripple frequency

3-45. In a voltage regulator, what percent of regulation would be ideal?

1. 1 percent
2. 0 percent
3. 3 percent
4. 5 percent

NEETS MODULE 6-Electronic Emission, Tubes, and Power Supplies
UNCLASSIFIED

IN ANSWERING QUESTIONS 3-46 THROUGH 3-48, REFER TO THE FOLLOWING FORMULA:

$$\text{Percent of Regulation} = \frac{E_{\text{no load}} - E_{\text{full load}}}{E_{\text{full load}}} \times 100$$

- 3-46. If a power supply produces 30 volts with no load and 25 volts under full load, what is the percent of regulation?
1. 5 percent
 2. 10 percent
 3. 20 percent
 4. 30 percent
- 3-47. If a power supply produces 10 volts with no load and 9 volts under full load, what is the percent of regulation?
1. 8 percent
 2. 9 percent
 3. 10 percent
 4. 11 percent
- 3-48. If a power supply produces 20 volts with no load and 20 volts under full load, what is the percent of regulation?
1. 1 percent
 2. 2 percent
 3. 3 percent
 4. 0 percent
- 3-49. The simple series voltage regulator was designed to function as what type of resistance?
1. Fixed resistance in series with the load
 2. Fixed resistance in parallel with the load
 3. Variable resistance in series with the load
 4. Variable resistance in parallel with the load

NEETS MODULE 6-Electronic Emission, Tubes, and Power Supplies
UNCLASSIFIED

- 3-50. In a simple shunt voltage regulator, what is the purpose of the shunt element?
1. To regulate voltage through series resistance R_s
 2. To regulate voltage through parallel resistance V_1
 3. To regulate current through series resistance R_s
 4. To regulate current through parallel resistance V_1
- 3-51. In an electron tube voltage regulator, the electron tube replaces which of the following components?
1. Variable resistor R_v
 2. Parallel resistor R_p
 3. Series resistor R_s
 4. Load resistor R_L
- 3-52. The primary purpose of the amperite regulator is to regulate
1. power
 2. voltage
 3. current
 4. resistance
- 3-53. What method is used by a manufacturer of electronic equipment to reduce the cost of extensive wiring?
1. Grounding the output of the power supply to the chassis
 2. Grounding the return side of the power transformer to the chassis
 3. Connecting all components in parallel
 4. Connecting all components in series
- 3-54. When working on electronic equipment, the technician should observe which of the following safety precautions?
1. Make certain that the electronic equipment is properly grounded
 2. Make certain that the test equipment is properly grounded
 3. Make certain that the rubber mats are in good condition
 4. All of the above

NEETS MODULE 6-Electronic Emission, Tubes, and Power Supplies
UNCLASSIFIED

- 3-55. Which of the following is/are the most widely used check(s) for testing electronic equipment?
1. Smoke
 2. Visual
 3. Signal tracing
 4. Both 2 and 3 above
- 3-56. Any connection that is located close to the chassis or any other terminal should be examined for the possibility of which of the following problems?
1. A short
 2. An open
 3. A low resistance
 4. A high resistance
- 3-57. What is the condition of a transformer that is discolored or leaking?
1. Operational
 2. Shorted
 3. Cracked
 4. Open
- 3-58. As a technician, you notice that a resistor is discolored and charred. The resistor has most likely been subjected to which, if any, of the following conditions?
1. Overload
 2. Open circuit
 3. Ambient temperature
 4. None of the above
- 3-59. You are in the process of energizing a power supply. You hear a boiling or sputtering noise and notice smoke coming from a section of the power supply. Which, if any, of the following actions should you take first?
1. Secure power immediately
 2. Examine the problem area
 3. Remove the defective component
 4. None of the above

NEETS MODULE 6-Electronic Emission, Tubes, and Power Supplies
UNCLASSIFIED

- 3-60. Which, if any, of the following is the most rapid and accurate method for testing electronic circuits?
1. Smoke test
 2. Visual test
 3. Signal tracing
 4. None of the above